

FENCING RULES

*Authorized English Translation
of the
International (FIE) Rules*



Adopted by

The Amateur Fencers
League of America

The National Collegiate
Athletic Association

FENCING

RULES FOR COMPETITIONS

An authorized translation of the
Règlement pour les Épreuves
of the Fédération Internationale d'Éscrime

by Joseph A. Byrnes

prepared with the cooperation of
Miguel de Capriles
Membre d'Honneur and past President, FIE

© Amateur Fencers League of America, Inc., 1974

FOREWORD

This rules book, published by the Amateur Fencers League of America, Inc. (AFLA), is basically a fresh translation of the FIE Reglement, in the 1973 edition, with the further changes and corrections adopted by the FIE Congress of 1973. It has been adopted by the AFLA for use in the United States. (In the domestic edition, for the guidance of fencers in the USA, certain supplemental material has been bound in: the Operations Manual and the Bylaws of the AFLA, chapters on the NCAA practices in organizing tournaments and in disciplinary procedures, plus various American fencing records.)

The AFLA, founded in 1891, is a non-profit, tax-exempt organization, consisting of geographically distributed divisions, primarily engaged in increasing participation in the sport of fencing. The AFLA is the official governing body for fencing activities in the USA, and is so recognized by the United States Olympic Committee and the International Fencing Federation (FIE).

Membership in the AFLA is open to all persons who have any interest in fencing. As part of their membership, the bi-monthly magazine *American Fencing*, the official publication of the League, is sent to all members. Application forms and informational brochures ("Questions and Answers re the AFLA," "How to Understand and Enjoy the Sport of Fencing," and others) are available on request from: the Secretary, AFLA, Inc., 249 Eton Place, Westfield, New Jersey 07090.

The rules governing amateur fencing in the United States are enacted, amended, and repealed solely by the Board of Directors of the AFLA, Inc. As a matter of policy, the AFLA follows the rules enacted by the International Fencing Federation (FIE), with occasional minor exceptions that are duly announced.

N.B.: The technical provisions in this rule book are mandatory without variation for all AFLA championships and nationally-rated competitions. Unless exceptions have been announced in advance by the appropriate authorities, they are also applicable to all events scheduled by any section or division of the AFLA, or held under AFLA auspices.

The publication of this book represents a cooperative effort by the Amateur Fencers League of America, the National Collegiate Athletic Association, and the National Fencing Coaches Association of America—an effort that is hitherto unprecedented in sports, and a happy augury for future developments.

A Note on This Translation

The international fencing language is French, and in all international events only the French text of the rules "fait foi." However, every nation fences in its own language, and develops a *salle jargon* of its own—part French and part translation. This text, intended for the English-speaking fencers of North America, translates some terms that are elsewhere often retained in French ("Director" for "President") and translates differently some others (usually "touch" or "cut" instead of "hit"). In most such cases, and wherever else it seemed advisable, the French term has been entered in quotation marks and square brackets, e.g., ["piste"], immediately following the English version in the text, at least at its first appearance. The brackets have also been used alone, sparingly but where appropriate, to supply supplemental information, such as alternative nomenclature or brief explanations, none of which appears in the original French text. In the interest of facilitating direct comparisons, an effort has been made to retain the detailed organization of the original. Equivalents for metric measurements have not been inserted in the text; however, a list of metrical sizes and weights applicable to fencing, together with their equivalents in English measures, has been included at the end.

RULES FOR COMPETITIONS TABLE OF CONTENTS

PART ONE: GENERAL RULES AND RULES APPLICABLE TO ALL THREE WEAPONS

| | Articles |
|--|----------|
| CHAPTER I — HISTORICAL NOTE | |
| CHAPTER II — APPLICABILITY OF RULES | |
| 1. Mandatory application of the rules | 1 |
| 2. Exceptions to the rules | 2 |
| CHAPTER III — TERMINOLOGY | |
| A. Director ["Président"] | 3 |
| B. Competitions | |
| 1. Freeplay and bout | 4 |
| 2. Team match | 5 |
| 3. Competition | 6 |
| 4. Championship | 7 |
| 5. Tournament | 8 |
| C. Explanation of certain technical terms most often used in judging fencing | |
| 1. Fencing time | 9 |

| | |
|---|------|
| 2. Offensive and defensive actions | 10 |
| 3. Counter attacks | 12 |
| 4. Kinds of offensive actions | 13 |
| CHAPTER IV – FIELD OF PLAY [“TERRAIN”] | 14 |
| CHAPTER V – FENCERS’ EQUIPMENT | |
| 1. Responsibility of the fencers | 16 |
| 2. Inspection of fencers’ equipment: | |
| a. Presentation of equipment for inspection | 17 |
| b. Organization of inspection | 17 |
| c. Personnel and equipment for carrying out the inspection .. | 20 |
| 3. Non-regulation equipment | 21 |
| 4. Specifications common to all weapons | 22 |
| 5. General requirements for clothing and equipment | 27 |
| CHAPTER VI – FENCING [“COMBAT”] | |
| 1. Manner of fencing | 28 |
| 2. Distinctness of the touch | 29 |
| 3. Manner of holding the weapon | 30 |
| 4. Putting on guard | 31 |
| 5. Beginning, stopping and restarting the bout | 32 |
| 6. Fencing at close quarters [infighting] | 33 |
| 7. Corps à corps | 34 |
| 8. Evasive actions, displacing the target, passing the opponent .. | 35 |
| 9. Ground gained or lost | 36 |
| 10. Crossing the boundaries of the strip | 38 |
| 11. Duration of the bout | 45 |
| 12. Accidents – indispositions – withdrawal of a fencer | 50 |
| CHAPTER VII – THE DIRECTION OF A BOUT AND THE JUDGING OF TOUCHES | |
| 2. Officials | |
| 1. The Director | 53 |
| 2. The Jury, Judges and Floor Judges | 54 |
| 3. Auxiliary personnel | 59 |
| B. Judging by a jury | |
| 1. Duties of the Director | 61 |
| 2. Location of the Jury | 62 |
| 3. Judging | |
| a. Procedure | 63ff |
| b. Materiality of the touch | 68f |
| c. Validity or priority of the touch | 70 |
| C. Judging with a scoring machine | |
| 1. Direction of the bout | 71 |
| 2. Judging | |
| a. Materiality of the touch | 72 |
| b. Validity or priority of the touch | 75 |

PART TWO: FOIL

CHAPTER I – HISTORICAL NOTE

| | |
|--|-------|
| CHAPTER II – FIELD OF PLAY [“TERRAIN”] | 201 |
| CHAPTER III – EQUIPMENT OF FOIL FENCERS | |
| A. Weapons | |
| 1. General specifications for the foil | 205 |
| 2. Specifications for the electrical foil | 211 |
| B. Clothing and equipment | |
| 1. General specifications for clothing and equipment for all foil fencers | 212ff |
| 2. Specifications for clothing and equipment necessary for electrical foil | 216ff |
| CHAPTER IV – THE CONVENTIONS OF FENCING WITH THE FOIL | |
| A. Method of making touches | 219 |
| B. Valid surface [target] (illustration) | |
| 1. Limitation of the valid surface | 220 |
| 2. Extension of the valid surface | 222 |
| 3. Invalid surface [off-target] | 223 |
| C. Corps à corps and fleches | 224 |
| D. Number of touches—Duration of the bout | 225f |
| E. Judging touches in foil | 227 |
| I. Materiality of the touch | |
| 1. With a jury (see article 61ff) | |
| 2. With a scoring machine | 228ff |
| II. Validity or priority of the touch | |
| 1. Preliminary note | 232 |
| 2. Observance of the phrase d’armes | 233ff |
| 3. Judging | 237 |

PART THREE: EPEE

NOTE

CHAPTER I – HISTORICAL NOTE

| | |
|---|-------|
| CHAPTER II – FIELD OF PLAY [“TERRAIN”] | 301ff |
| CHAPTER III – EQUIPMENT OF EPEE FENCERS | |
| A. Weapons | |
| 1. General specifications for the épée | 306ff |
| B. Equipment | |
| 1. Mask | 313 |
| 2. Body wire | 314 |
| C. Clothing | 315 |
| CHAPTER IV – CONVENTIONS OF EPEE FENCING | |
| A. Manner of making touches | 316 |
| B. Valid surface [target] (illustration) | 317 |
| C. Corps à corps and fleches | 318 |
| D. Number of touches – Duration of the bout | 319 |
| E. Judging touches in épée | 322 |
| I. Materiality of the touch | |

| | |
|---|-----|
| 1. Fundamental rule | 323 |
| 2. Annulment of touches | 324 |
| II. Validity or priority of the touch | |
| 1. Principle | 329 |
| 2. Judging | 330 |

PART FOUR: SABRE

| | |
|--|-------|
| CHAPTER I – HISTORICAL NOTE | |
| CHAPTER II – FIELD OF PLAY ["TERRAIN"] | 401ff |
| CHAPTER III – EQUIPMENT FOR SABRE | |
| A. Weapons | |
| 1. General specifications for the sabre | 404ff |
| B. Equipment and clothing | 408 |
| CHAPTER IV – CONVENTIONS OF SABRE FENCING | |
| A. Manner of making touches | 409 |
| B. Valid surface [target] | |
| 1. Limitation of the valid surface | 410 |
| 2. Invalid surface (illustration) | 411 |
| C. Corps à corps and flèches | 412 |
| D. Number of touches – Duration of the bout | 413f |
| E. Judging touches in sabre | 415 |
| I. Materiality of the touch (see article 68ff) | |
| II. Validity of the touch | |
| 1. Preliminary note | 416 |
| 2. Observance of the phrase d'armes | 417 |
| 3. Judging | 422 |

PART FIVE: ORGANIZATION OF COMPETITIONS

| | |
|--|-------|
| CHAPTER I – COMPETITIONS | 501 |
| CHAPTER II – RESPONSIBILITY FOR SUPERVISION AND INSPECTION | |
| 1. Organizing Committee | 503 |
| 2. Central Office of the FIE | 504 |
| 3. Directoire Technique | 505 |
| 4. Jury of Appeal | 506ff |
| 5. Jury | 512 |
| 6. Auxiliary personnel | 516 |
| a. Scorekeepers | |
| b. Timekeepers | |
| c. Machine operator | |
| d. Experts [Technicians] | |
| e. Repairmen | |
| 7. Inspection of equipment | 517 |
| CHAPTER III – ENTRIES FOR COMPETITIONS | 518 |

| | |
|--|-------------|
| CHAPTER IV – INSPECTION PRELIMINARY TO A COMPETITION (See Article 17ff) | |
| CHAPTER V – SCHEDULE | 519ff |
| CHAPTER VI – INDIVIDUAL COMPETITIONS | 522 |
| Formulas for organization | |
| A. By pools | |
| 1. Number of fencers to a pool | 523 |
| 2. Composition of pools | 524f |
| 3. Order of bouts | 526ff |
| 4. Classification [standing] in the pools | 528 |
| 5. Promotion to the next round (qualification) | 529 |
| 6. Fence-off ["Barrage"] | 530 |
| 7. Final pool – classification | 531 |
| 8. A fencer not finishing a competition | 532ff |
| B. By pools with the mixed formula of pools of 4 | 541 |
| 1. Formula for the competition | 542f |
| 2. Composition of the pools | 544f |
| 3. Classification [standing] in the pools | 546 |
| 4. Promotion to the next round (qualification) | 546 |
| 5. Order of bouts | 547 |
| 6. Final pool – classification | 548 |
| C. By direct elimination, integral formula | |
| 1. Application of rules | 549 |
| 2. Organization of the competition | 550 |
| 3. Formula for the individual matches | 551 |
| 4. Duration of individual matches | 552 |
| 5. Withdrawal of a fencer | 553 |
| 6. Order of the individual matches | 554 |
| 7. Classification [standing] | 555 |
| Tables for direct elimination | 563 |
| D. By direct elimination with the mixed formula of two rounds of elimination pools and a direct elimination table with repêchage, qualifying 6 fencers for a final pool. | |
| 1. Elimination rounds | 556 |
| 2. Classification in the pools and qualification | 557 |
| 3. Composition of the direct elimination table | 558 |
| 4. Formula for the individual matches | 559 |
| 5. Repêchage – Principles | 560 |
| 6. Order of the individual matches – Qualification | 561 |
| 7. Final pool – Classification | 562 |
| 8. Tables for direct elimination | 563 |
| Tables of indicators | Pages 87-99 |
| CHAPTER VII – TEAM COMPETITIONS | |
| 1. Formulas for organization | 564 |
| 2. Composition of teams | 565 |
| 3. Order of bouts | 566 |
| 4. Classification [standing] of teams | |
| a. Match between two teams | 567 |
| b. Classification of several teams in the same pool | 568 |
| c. Withdrawal of a team member during a match | 569 |

- d. A team not completing a competition570
- A. Team competitions by direct elimination, integral formula
 - a. Principle571
 - b. Formula for the team matches572
 - c. Fence-offs ["barrages"]573
- B. Team competitions by mixed formula: pools and direct elimination574
 - 1. Composition of the pools575ff
 - 2. Formula for quality points576
 - 3. Direct elimination table577
 - 4. Classification [final standing] for places after 1st and 2nd578

CHAPTER VIII - SPECIAL RULES FOR THE WORLD CHAMPIONSHIPS, HISTORICAL NOTE

- A. Individual championships
 - 1. Annual championship
 - 2. Bids ["Candidatures"]579
 - 3. Entries580
 - 4. Formula for the competitions581
- B. Team championships
 - 1. Simultaneity582
 - 2. Entries583
 - 3. Formula584
- C. Provisions common to all championship events
 - 1. Participation585
 - 2. Entries586
 - 3. FIE Rules587
 - 4. Order of events588
 - 5. Directoire Technique589
 - 6. Supervision by the FIE590
 - 7. Number of touches591
- D. The Olympic Games592

CHAPTER IX - RULES FOR THE WORLD UNDER-20 CHAMPIONSHIPS

- 1. Frequency of the Championships593
- 2. Bids ["Candidatures"]594
- 3. Entries595
- 4. Age of Participants596
- 5. Rules597
- Directoire Technique598
- 6. Order of the events599

PART SIX: DISCIPLINARY CODE FOR COMPETITIONS

CHAPTER I - APPLICABILITY

- 1. Persons subject to these rules601
- 2. Order and discipline602
- 3. Competitors603ff
- 4. Doping608
- 5. Team captain609
- 6. Members of the jury610

- 7. Coaches, trainers and technicians611
- 8. Spectators612

CHAPTER II - THE DISCIPLINARY AUTHORITIES AND THEIR COMPETENCE

- 1. Bodies having jurisdiction613
- 2. Principle of jurisdiction614
- 3. Director ["Président de jury"]615
- 4. Organizing Committee616
- 5. Directoire Technique617
- 6. Jury of Appeal618
- 7. Executive Committee of the International Olympic Committee at the Olympic Games619
- 8. National Federation620
- 9. Central Office of the FIE621
- 10. Congress of the FIE622

CHAPTER III - PENALTIES

- 1. Classes of penalties623
- 2. Competitive [Combat] penalties:
 - a. Loss of ground624
 - b. Refusal to award a touch actually made625
 - c. Award of a touch not actually received626
 - d. Exclusion from the competition627
- 3. Disciplinary penalties:
 - e. Exclusion from the competition628
 - f. Exclusion from the entire tournament629
 - g. Suspension630
 - h. Permanent suspension ["radiation"]631
 - i. Disqualification632
 - j. Expulsion from the site of the competition or tournament633
- 4. Announcement of penalties634

CHAPTER IV - OFFENSES, THEIR PENALTIES, AND THE COMPETENT AUTHORITIES

- 1. Preliminary note635
- 2. Warning636
- 3. Competitive offenses
 - a. Competent authority637
 - b. Offenses related to the field of play638
 - c. Offenses related to the duration of the bout639
 - d. Improper use of the unarmed hand or arm640
 - e. Seeking the corps à corps641
 - f. Removal of the mask641add.
 - g. Dishonest or incorrect fencing642
 - h. Favoring an opponent643
 - i. Collusion with an opponent644
 - j. Violence and brutality645
 - k. Indisposition646
 - l. Accident647
- 4. Offenses against sportsmanship
 - a. Non-conformity of equipment648
 - b. Placing an uninsulated part of the weapon in contact with

- the metallic vest(648)
- c. Non-observance of the regulations for the competition ... 649
- d. Violation of the rules on amateurism 650
- e. Doping 651
- f. Partiality of judges 652
- g. Other offenses 653
- 5. Offenses against the maintenance of order
 - a. Failure to appear on time 654
 - b. Interfering with order 655
 - c. Spectators or others interfering with order 656
- 6. Offenses concerning discipline 657

CHAPTER V – PROCEDURE

- 1. Principle 658
- 2. Protests and appeals 659
- 3. Investigation; Right of defense 661
- 4. Method of decision 662
- 5. Reprieve 663
- 6. Repetition of offense 664
- 7. Pardon, remission and commutation of penalty 665

PART SEVEN: EQUIPMENT FOR THE AUTOMATIC
REGISTRATION OF TOUCHESCHAPTER I – RULES APPLICABLE TO ALL EQUIPMENT
FOR THE REGISTRATION OF TOUCHES

- 1. Authorized models 701
- 2. Composition of the equipment 702
- 3. Approval of models 703
- 4. Inspection of equipment before each competition 708
- 5. Specifications to be met by all electrical equipment:
 - a. Scoring machine 709
 - b. Reels, floor cables and connectors 710
 - c. Metallic strip 711
 - d. Weapons 712

CHAPTER II – SPECIAL REQUIREMENTS TO BE MET BY
THE VARIOUS PARTS OF ELECTRICAL
FOIL EQUIPMENT

A. Fixed equipment

- 1. Scoring machine:
 - a. Principles 713
 - b. Sensitivity and reliability 714
 - c. Extension lamps 715
 - d. Source of electrical power 716
- 2. Reels, floor cables and connectors 717

B. Weapons

- 1. Principle 718
- 2. Points and buttons 719
- 3. Attachment of the button 720
- 4. Insulation of the button and blade 722

- C. Metallic vests, masks and body wires 722

CHAPTER III – SPECIAL REQUIREMENTS TO BE MET BY
THE VARIOUS PARTS OF ELECTRICAL
EPEE EQUIPMENT

A. Fixed equipment

- 1. Scoring machine:
 - a. Principle 723
 - b. Timing adjustment 724
 - c. Sensitivity 725
 - d. Non-registration 726
 - e. Light signals 727
 - f. Sound signals 728
 - g. Source of electric current 729
- 2. Reels, floor cables, connectors and body wires 730

B. Weapons

- 1. Principle 731
- 2. Points and buttons 732
- 3. Attachment of the button 733

NOTES

"see" followed by a number: refer to the article so numbered.

"f" after a number: and the following article.

"ff" after a number: and the following articles.

Articles are numbered within parts without continuity from part to part; the digit in the hundreds position corresponds to the number of the part [except for part one]:

Part One (General Rules) begins with Article 1.

Part Two (Foil) begins with Article 201.

Part Three (Epee) begins with Article 301.

Part Four (Sabre) begins with Article 401.

Part Five (Organization of Competitions) begins with Article 501.

Part Six (Disciplinary Code) begins with Article 601.

Part Seven (Equipment) begins with Article 701.

RULES FOR COMPETITIONS

It is presumed that everyone knows the rules.
[Ignorance of the rules is no excuse.]

PART ONE: GENERAL RULES AND RULES APPLICABLE TO ALL THREE WEAPONS

CHAPTER I—HISTORICAL NOTE

The Rules of the Fédération Internationale d'Escrime (FIE) were adopted unanimously by the International Congress of National Olympic Committees held at Paris in June, 1914, for use in all competitions at the Olympic Games. They were codified for the first time in 1914 by the Marquis de Chasseloup-Laubat and M. Paul Anspach, and published in 1919 under the title "Rules for Competitions."

They were modified by different Congresses of the FIE and in 1931 were revised anew. The 1954 Congress rearranged and retitled them as "Technical Rules"; the 1958 Congress revised them again under the former title "Rules for Competitions."

The modifications enacted by the Congresses held between 1964 and 1972 have been integrated in the new edition prepared in 1972 [and issued in 1973].

CHAPTER II—APPLICABILITY OF THE RULES

§ 1. Mandatory application of the rules

1 The provisions of the present rules are mandatory without exception for the "official FIE competitions," which are:

- the World Championships,
- the fencing events of the Olympic Games,
- the World Under-20 Championships.

The present rules must also be followed at every international competition of whatever sort unless exceptions have been announced in advance.

§ 2. Exceptions to the rules

2 Exceptions must be confirmed by the national governing body for fencing in the country to which the organizing committee belongs, and must be called to the attention of all concerned in the announcement of the competition (see 1).

CHAPTER III—TERMINOLOGY

A. DIRECTOR [PRESIDENT OF THE JURY]

3 Throughout the text of the present rules, the word **Director** will be used to mean "Director of Combat" or "Président de Jury" [the latter is the French term used internationally].

B. COMPETITIONS

§ 1. Free play and bout

4 Friendly combat between two fencers is called "free play" ["assault"]; when the score is kept in a competition, it is called a "bout" ["match"].*

§ 2. Team match

5 The total of bouts between the fencers of two different teams is called a "match" ["recontre"].

§ 3. Competition

6 A competition is the aggregate of the bouts (in an individual competition) or of the team matches (in a team competition) necessary to determine the winner of the competition ["épreuve"].

Competitions are classified according to the weapons, the sex of the competitors, or their age, or their occupation (members of the armed forces, students, etc.), and by whether they are competitions for individuals or for teams.

Competitions are said to be "by direct elimination" when the competitors are eliminated upon their first loss (or after their second if the rules provide for a repêchage table); a "pool" ["poule"], on the other hand, is a group of several competitors (or of all the competitors) who all fence each other successively to determine their respective classification.

§ 4. Championship

7 Championship ["championnat"] is the name given to a competition held to ascertain the best fencer or the best team in each weapon, within a sports organization, in a given area, and for a set period of time.

§ 5. Tournament

8 Tournament ["tournoi"] is the name given to the whole of the competitions held at the same place, in the same period of time, and on the same occasion.

C. EXPLANATION OF CERTAIN TECHNICAL TERMS MOST OFTEN USED IN JUDGING FENCING.**

* [In international competitions, fencers should be alert to the possibilities for confusion created by the different French and English meanings of the term "match."]

** It is understood that this chapter does not serve as a treatise on fencing and that it appears here only to aid the reader in understanding the rules.

§ 1. Fencing time

- 9 Fencing time [or: period of fencing time; "Temps d'escrime"] is the time required to perform one simple fencing action.

§ 2. Offensive and defensive actions

- 10 The different offensive actions are the attack, the riposte, and the counter-riposte.

The attack is the initial offensive action executed by extending the arm and continuously threatening the opponent's valid surface [target] (see 233ff, 417ff).

The riposte is the offensive action made by the fencer who has parried the attack.

The counter-riposte is the offensive action made by the fencer who has parried the riposte.

The different defensive actions are the parries.

The parry ["parade"] is the defensive action made with the weapon to prevent the attack from touching.

Parries are simple, or direct, when they are made in the same line as the attack.

They are circular (counter) when they are executed in the line opposite to that of the attack.

- 11 **Offensive Actions:**
a) Attack or riposte

The action is simple when it is executed in a single movement; either direct (in the same line), or indirect (in another line).

The action is composite when it is executed in several movements.

b. Riposte

The riposte is immediate or delayed ["à temps perdu"]; this is a question of fact [what action is performed] and of the speed of execution.

Examples:

1. Simple direct ripostes:

Direct [straight] riposte: a riposte which touches the opponent without having left the line in which the parry was made.

Riposte along the blade: a riposte which touches the opponent by gliding along the blade after the parry.

2. Simple indirect ripostes:

Riposte by disengagement: a riposte which touches the opponent in the line opposite to that in which the parry was made (by passing beneath his blade, if the parry was in the high line, and over the blade, if the parry was in the low line).

Riposte by coupé [cutover]: a riposte which touches the opponent in the line opposite to that in which the parry was made (in all cases, by passing the blade over the opponent's point).

3. Composite ripostes:

Riposte with a double: a riposte which touches the opponent in the line opposite to that in which the parry was made, but after having described a full circle around the opponent's blade.

Riposte by one-two: a riposte which touches the opponent in the line in

which the parry was made, but after having first been in the opposite line, passing under his blade.
And so forth.

§ 3. Counter attacks

- 12 Counter attacks are offensive or defensive-offensive actions executed during the opponent's attack:

- a) The Stop [stop thrust or cut]: is a counter attack made on an attack.
b) The Stop with opposition (formerly called the "time thrust" or "time hit"); is a counter attack executed while closing the line in which the opponent's attack will be terminated (see 233ff, 329ff, and 418ff).
c) The Stop in time: is made with a period of fencing time (see 236, 421).

§ 4. Kinds of offensive actions

- 13 a) Remise

The remise is an immediate simple offensive action which follows an original action; it is made without withdrawing the arm, after the opponent's parry or retreat, either because the latter gives up contact with the blade without riposting, or delays his riposte, or attempts an indirect or composite riposte.

b) Redoublement

The redoublement is a new action, either simple or composite, made against an opponent who has parried without riposting, or has simply evaded the first action by a retreat or a displacement.

c) Reprise d'attaque [retaking of the attack]

The reprise is a new attack executed immediately after a return to the guard position.

d) Counter time

Counter time describes every action made by an attacker against his opponent's stop.

CHAPTER IV—FIELD OF PLAY ["TERRAIN"]

(See 201ff, 301ff, 401ff)

- 14 The field of play must present an even surface. It may not offer either an advantage or a disadvantage to either of the two competitors, particularly as regards gradient or light.

In announcing a tournament, the organizers must always specify the type of surface on which the events will be fenced. They must be particularly specific when the events will be fenced in the open air.

- 15 The portion of the field of play used for fencing is called the strip ["piste"]. The strip may be of earth, wood, linoleum, cork, rubber, plastic, metal, metallic mesh, or of a material with a metallic base (see 201, 304, 401).

The width of the strip is from 1.8 to 2 meters; its length varies according to the weapon (see 202, 302, 402).

Besides the length specified for each weapon, the strip should be extended at each end by 1.5 to 2 meters, to allow the fencer who is going to cross the rear limit to retreat over an even and unbroken surface.

PLAN OF THE USUAL 3-WEAPON STRIP

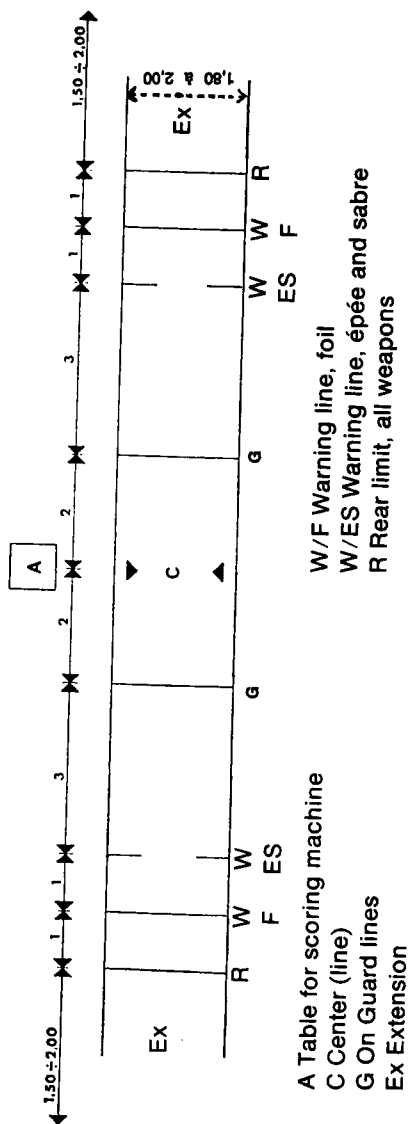

In electric foil and épée, the metallic strip must cover the full width of the strip and its full length, including the extensions at the ends (see 711).

Note: the figures on the plan indicate the dimensions in meters.

If the strip is placed on a platform, the latter may not be more than 0.5 meter high.

If, for practical reasons, the strip cannot be of the regulation length, its length may not in any case be less than 1.3 meters, including the extensions mentioned above.

CHAPTER V—FENCERS' EQUIPMENT

(Weapons — Other Equipment — Clothing)

(See 205ff, 308ff, 404ff)

§ 1. Responsibility of fencers

16 Fencers arm, equip and clothe themselves and fence on their own responsibility and at their own risk and peril.

Fencers alone may be held responsible in all respects for accidents in which they figure as agents or as victims.

The safety precautions as well as the inspection procedures specified in these rules are intended only to improve the safety of the fencers, and cannot guarantee it absolutely; consequently, whatever may be the manner in which they are applied, they cannot entail liability on the part of the FIE, or of the organizers of a competition, or of the officials in charge of the latter, or of those who may cause an accident.

§ 2. Inspection ["Contrôle"] of fencers' equipment

(See 53)

17 Fencers are responsible for the condition of their gear (weapon and other equipment and clothing) at the moment they appear on the strip.

The inspection procedures prescribed by the present rules are intended only to assist the organizers who must enforce the rules and the fencers who must abide by the rules. Accordingly, the existence of inspection procedures cannot in any way relieve the fencers of responsibility for infractions of the rules.

A. Presentation of equipment for inspection

Fencers are required to present themselves, at the hour specified in the program of each official FIE competition, at the Inspection Station ["Bureau de Contrôle des Armes"], with the equipment intended for use in the competition. Fencers or team captains may not ask for the return of the inspected equipment until one hour before the beginning of the competition.

The repair of equipment rejected in the course of inspection may be carried out in the repair shop. However, such repaired equipment will not be

§ 3. Non-regulation equipment

(See 18, 648.)

21

Under whatever circumstances a fencer on the strip is found to be in possession of non-regulation or defective equipment, that equipment will be immediately confiscated and turned over to the experts on duty for examination. The equipment in question will not be returned to its owner until any repairs shown necessary by the examination have been made, and, in such case, after payment of the cost of the repair. Before being used again, the equipment must be re-inspected.

A. If preliminary inspection of equipment has been carried out:

1. When a fencer appears on the strip:

- with a non-working weapon or body wire, or
 - without a protective undergarment, or
 - with a metallic vest that does not completely cover the valid surface,
- the Director will give the fencer a warning valid for that pool, that team match, or during the direct elimination bouts.

In case of repetition, he will impose one penalty touch for each offense.

2. When in the course of a bout an irregularity is demonstrated that could have arisen from the fencing:

Examples:

- metallic vest with holes on which valid touches do not register,
- body wire or weapon no longer working,
- spring pressure having become insufficient,
- travel of the point no longer correct,

the Director will impose neither warning nor penalty. Moreover, a valid touch that has been scored with a weapon that has thus become defective will be awarded.

3. If, at the fencer's first appearance on the strip or in the course of a bout, it is established that equipment being used by that fencer:

- a) does not bear the mark of the preliminary inspection, the Director will annul the last touch that may have been scored by the fencer at fault, and

will give the fencer a warning valid for that pool, that team match, or the bouts by direct elimination.

In case of repetition, he will impose one penalty touch for each offense.

- b) is non-regulation in some point not susceptible to preliminary inspection (e.g., the mask), the Director will give the fencer at fault a warning valid for that pool, that team match, or the bouts by direct elimination.

In case of repetition, he will impose one penalty touch for each offense.

- c) has been approved by the preliminary inspection, but presents irregularities that could have come from deliberate modifications.

d) carries imitation or misplaced inspection marks.

- e) has been modified to permit the scoring of touches at will or to block the operation of the scoring apparatus.

In any of the cases in c), d), e), the Director must immediately confiscate the equipment (weapon, body wire, or metallic vest) and have it examined by the expert on duty.

After securing the opinion of the expert (for the official FIE competitions, a member of the Commission on Electrical Scoring and Equipment) who has made the examination (see 517), the Director will impose the penalties set

forth below, without prejudice to subsequent application of Article 615/d.

- for the cases in c) and d), at the first infraction, a penalty of one touch and the annulment of the last touch that may have been scored by the fencer at fault.

In case of repetition, exclusion from the tournament; the Directoire Technique will be advised of the penalty.

- for the case in e), the penalty is immediate exclusion from the tournament; the Directoire Technique will be advised of the penalty.

While waiting the Director's decision, the bout is interrupted, but the other bouts in the pool may continue.

B. If there has been no preliminary inspection of equipment:

In this case, only the provisions set forth above in paragraphs 1, 2, 3/b and 3/e of Article 21/A are applicable. Otherwise, if at the first appearance of a fencer on the strip or in the course of a bout, an irregularity in size or in some other characteristic of his equipment is observed, the Director shall allow the time necessary for the fencer to put himself in order and shall give him a warning valid for that pool, that team match, or for the bouts by direct elimination. In case of repetition, he will inflict a penalty touch for each recurrence, and the touch that may have been scored by this fencer will be annulled.

General Provisions.

C. The members of the Commission on Electrical Scoring and Equipment have the right, at any time, to call in for inspection a weapon, a body wire, a metallic vest, or any part whatsoever of a fencer's equipment or clothing.

D. Note: Besides the penalties detailed above, the rules for judging specify, for each weapon, all the grounds for annulment and non-annulment of touches made in the course of a bout.

§ 4. Specifications common to all weapons

22

All weapons are authorized, under the sole condition that they conform to the rules.

The weapon is so constructed that normally it cannot injure either the fencer or his opponent. All efforts to modify a blade by changing its flexibility, whether by grinding or filing or other method, are prohibited (see 207, 308, 406).

A. General description:

23 Every weapon is composed of the following parts:

1. A blade of flexible steel, terminated at its front end by a button and at the back end by the tang, which is included in the hilt when the weapon is assembled.

2. A hilt in which the tang is fastened by a nut or by any other means, and which permits the fencer's hand to hold the weapon. The hilt may be composed of one or of several parts; in the latter case, it breaks down into a handle, which the hand normally holds, and the pommel (the rear part of the hilt which fastens the handle onto the tang).

3. A metal guard ["coquille"], fastened convex side forward between the blade and the hilt, which serves to protect the hand holding the weapon. The guard may contain padding or a cushion (see 26/2, 712) to absorb shocks; in addition, in electrical weapons, it will include a socket to receive the body wire.

B. Dimensions:

(See 206ff, 307ff, 404ff.)

Each weapon has its proper shape and measurements.

24 1. The length of the blade includes the button, as well as anything added in front of the convex face of the guard, whether attached to it or not.

2. The total length of the weapon and of its different parts corresponds to the distances separating lines drawn parallel to each other and perpendicular to the axis of the blade; these lines are located:

- a) at the forward extremity of the weapon;
- b) at the point where the blade leaves the front convex surface of the guard;
- c) at the rear of the guard;
- d) between the handle and the pommel;
- e) at the rear extremity of the hilt.

3. The total length of the weapon is the distance between a and e; the length of the blade, that between a and b; the length of the hilt that between b and e; and the depth of the guard, that between b and c.

4. Since the maximum total length of a weapon is less than the sum of the greatest permissible lengths for blade and hilt considered separately, these two dimensions must compensate each other in calculating the overall length of any weapon.

5. During measurements, either of the total length of the weapon or of that of the blade, the latter must not be curved; therefore, it must be kept flat on a plane surface during the procedure.

6. Only the pommel or locking nut can be located between lines d and e.

C. Hilt:

25 1. In foil and epee, the maximum length of the hilt is 20 centimeters between lines b and e, and 18 cm between lines b and d. In sabre, the maximum length of the hilt is 17 cm (see drawings).

2. The hilt must pass through the same gauge as the guard. It is so constructed that it cannot, in normal use, injure either the fencer or his opponent.

3. All types of hilts are authorized provided that they conform to the regulations which are intended to put the various types of weapons upon a footing of equality.

4. The hilt may not include any device which would permit the weapon to be used as a throwing weapon.

5. The hilt may not include any device that would in any way increase the protection afforded the fencer's hand and wrist by the guard; a crossbar extending beyond the guard is specifically prohibited.

6. If the hilt (or the glove) includes any device or attachment which fixes the hand on the hilt, such device must meet the two following specifications:

- a) it must determine and fix only one position for the hand on the hilt;
- b) when the hand occupies this one position on the hilt, the tip of the thumb when completely extended may not be more than 2 cm from the inside surface of the guard.

D. Guard ["Coquille"]

(See 208, 310, 407.)

26 1. The convex face of the guard has a smooth, not too shiny surface, so constructed that it cannot catch or hold an opponent's point. Its rim may not be raised.

2. The padding inside the guard must be less than 2 cm thick and so arranged as not to increase the protection afforded the hand by the guard.

Buttons and points

(See 210f, 311f, 406f, 719f, 732f.)

See under each weapon and in Part VII, Chapters II and III.

§ 5. General requirements for clothing and equipment

27 1. The equipment and clothing of the fencer must assure the maximum protection compatible with the freedom of movement essential to fencing.

2. It must not, in any way, risk interfering with or injuring the opponent; neither may it include any buckle or opening that might, except accidentally, catch the opponent's point and thus hold or deflect it.

3. All garments must be white or of a very light tint. They must be made of sufficiently strong material and be in good condition.

The material used for equipment shall not present a slippery surface capable of making the point, the button, or an opponent's cut glance off (see 313, 408); the judging of touches shall be facilitated as much as possible.

4. In foil and sabre the bottom of the jacket must overlap the trousers by at least 10 cm when the fencer is on guard (see 212, 408).

In epee the fencer must wear a regulation jacket covering the entire surface of the trunk (see 315).

In all weapons the wearing of a protective undergarment is mandatory (see 212, 315, 408). The jacket and the collar must be completely closed and buttoned.

Women's equipment, in addition, must include in the jacket a breast protector of metal or some other rigid material (see 215).

5. The trousers [knickers] must be fastened below the knees. If the fencer wears long trousers, the bottoms shall either be buttoned or fastened above the feet.

With knickers, the wearing of a pair of white stockings is mandatory. They must cover the leg entirely up to the knickers and be fastened so that they cannot fall down.

6. In all weapons the cuff of the glove must always entirely cover the lower half of the forearm of the fencer's sword arm, to prevent an opponent's blade from entering the sleeve of the jacket.

7. The mask must be formed of mesh wherein the openings between the wires are at most 2.1 millimeters and of which the wires are of a minimum diameter of 1 mm before tinning, which should be carried out by a hot process after the mesh has been shaped.

In foil, the mesh of the mask must be insulated inside and out (see 722/4). The bib and trim must be white or of a very light tint.

CHAPTER VI—FENCING ["COMBAT"]**§ 1. Manner of fencing**

(See 16.)

28 Competitors fence in their own style and at their own risk and peril, on the sole condition that they observe the fundamental rules of fencing (see 35).

All fencing must, nevertheless, maintain a courteous and honest character. All violent actions (a flèche ending by jostling the opponent, disorderly play, abnormal displacements, any actions that the Director judges dangerous—for example, a running attack involving loss of balance, hits brutally delivered) are expressly prohibited (see 645).

The fencer on the strip must keep his mask on until the decision has been given by the Director (see 641 add.).

§ 2. Distinctness of the touch

29 In foil and in épée, every hit must arrive clearly and distinctly to be counted as a touch (see 219, 316).

In sabre, to be counted as touches, hits must be delivered clearly and distinctly with the point, with the front cutting edge, or with the back cutting edge (see 409).

§ 3. Manner of holding the weapon

30 In all three weapons, defensive actions are performed exclusively by the guard and the blade, used either separately or together.

In the absence of a special device or attachment, the fencer is free to hold the hilt as he pleases and may likewise, in the course of a bout, change the position of his hand. However, the weapon may not, permanently or temporarily, in an open or concealed manner, be transformed into a throwing weapon; it must be managed without the hand leaving the hilt, and, in the course of an offensive action, without sliding the hand along the hilt from front to rear.

The weapon is managed by one hand only; the fencer may not change hands until the end of a bout, unless given permission by the Director to do so because of injury to the hand or arm.

The use of the unarmed hand and arm is prohibited, both on offense and on defense. The penalty for a violation is annulment of a touch that may have been scored and the penalty of a touch, after a warning given in the course of the same pool, same team match, or the bouts by direct elimination (see 640/d).

In foil in the course of a bout, it is likewise prohibited to protect or cover the valid surface [target] with the unarmed hand or arm. The penalty for a violation is the annulment of a touch that might have been scored on his opponent by the fencer at fault, or the penalty of a touch, after a warning given in the course of the same bout (see 640/2).

§ 4. Putting on guard

31 The fencer first called must place himself on the Director's right, except in the case of a bout between a right-hander and a left-hander, if the left-hander is called first. The Director must place each of the two competitors so that his forward foot is 2 meters from the middle line of the strip (i.e., behind the "on-guard" line).

Placement on guard at the beginning of a bout and all replacements on guard are always made in the middle of the width of the strip. In sabre, during placement on guard at the center or at any other location on the

strip, the Director will see that the fencers scrupulously maintain their initial distance of 4 meters.

The guard position is assumed by the fencers on the Director's command "On guard" ["En garde"]. After which, the Director asks "Are you ready?" ["Etes-vous prêts?"] Upon an affirmative reply, or in the absence of a negative reply, he gives the command to begin: "Fence" [Play; "Allez"]. The fencers must place themselves on guard correctly and must maintain complete immobility until the Director's command "Fence."

In case the Director observes in the course of the bout that one of the fencers is using the unarmed hand or arm, he may ask for the assistance of two judges, as neutral as possible, who will be named by the Directoire Technique. These judges, located on each side of the strip, will each watch one fencer and indicate, by raising a hand or in response to the Director's question, any use of the unarmed hand or arm. The Director alone will decide the penalties to be imposed (See 640).

The Director may likewise have the two fencers change places, so that the one who commits this irregularity does not have his back toward him.

§ 5. Beginning, stopping and restarting the bout

32 1. As soon as the command "Fence" has been given, the competitors may begin offensive action. No action begun or completed before the command is counted.

2. The end of action is marked by the command "Halt" ["Halte"], except for special cases that change the regular and normal conditions of fencing (see also 47).

As soon as the command "Halt" has been given, a fencer may not begin a new action; only an action already under way remains valid. Everything which happens afterwards is completely invalid (but see 47).

If one of the fencers stops before the command "Halt" and is touched, the touch is valid.

The command "Halt" is also given if the play of the fencers is dangerous, confused or contrary to the rules, if one of the fencers is disarmed, if one of the fencers leaves the strip completely, or if, in retreating, he nears the spectators or judges (see 231/7).

3. After each touch awarded as valid, the fencers are put back on guard at the center of the strip. If the touch is not awarded, they are put back on guard in the positions they occupied when the bout was interrupted. (However, see 226, 321, 414).

The fencers change sides

— outdoors, after each touch;

— indoors, after each bout in direct elimination; or, in bouts for several touches, after one of the fencers has received half of the maximum number of touches that he can receive. In sabre, if one of the fencers is left-handed and if the Director cannot cross to the other side of the strip, the fencers will remain where they are and the judges will shift from right to left and vice versa.

However, with an electrical scoring machine, the fencers do not change sides during the bout. (However, see 31, 552).

4. Except in unusual circumstances, the Director may not permit a fencer to leave the strip. If a competitor does so without permission, he is liable to the penalties set forth in Article 654.

§ 6. Fencing at close quarters [infighting]

33 Fencing at close quarters is permitted as long as the fencers can use their weapons normally, and, in foil and sabre, as long as the Director can continue to follow the action ["phrase d'armes"].

§ 7. Corps à corps

34 The "corps à corps" exists when the competitors remain in bodily contact; in this case, the Director halts the bout (see 37, 224, 318, 412).

§ 8. Evasive actions, displacing the target, passing the opponent

35 Displacing the target, ducking under attacks, turns and half-turns are permitted, including ducking actions in which the unarmed hand may come in contact with the ground.

In the course of a bout, when a fencer passes his opponent, the Director must immediately give the command "Halt" and put the fencers back on guard in the places they occupied before the passing action occurred.

When touches are made in the course of a passing action, the touch made immediately [on the pass] is valid, and a touch made after passing the opponent is annulled; but one made immediately, even by turning around, by the fencer who has been attacked, is valid (see 638).

When in the course of a bout a fencer who has made a flèche attack has a touch registered against him and yet continues to run beyond the end of the strip far enough to tear free the reel or reel wire, the touch that he has received will not be annulled (see 625).

§ 9. Ground gained or lost

36 At the command "Halt," ground gained is held until a touch has been awarded. When they are put back on guard, the fencers must each retire an equal distance to reestablish fencing distance.

37 However:

a) When the bout has been stopped because of a corps à corps, the fencers are replaced on guard so that the one who sustained the corps à corps is at the place which he previously occupied; the case is the same if his opponent has made a flèche attack against him, even without a corps à corps.

b) A replacement on guard may not have the effect of putting behind the warning line a fencer who was in front of it when the bout was stopped, if this fencer has not already been warned (see 38).

c) A replacement on guard may not cause loss of ground to a competitor who was behind his warning line when the bout was interrupted.

§ 10. Crossing the boundaries of the strip

a) Stopping the bout

38 When a competitor crosses one of the boundaries of the strip with both feet, the Director must immediately call "Halt" and annul everything which happened after the crossing of the boundary, except a touch received by the fencer who crossed the boundary, even if it was

received after the crossing, provided it resulted from an immediate parry-riposte ["du tac-au-tac"].

When one of the fencers leaves the strip, only the touch scored under these conditions by the fencer who stays on the strip can be awarded, even in the case of a double touch, with the exception, however, of the case set forth in Article 42.

b) Rear limits and warning lines.

39 When a fencer's rear foot has reached his warning line for the last time, according to the rules proper to each weapon, the Director gives the command "Halt" and warns the fencer of the ground remaining to him before he will cross over the rear limit of the strip. He repeats this warning each time that the fencer, after having regained his on-guard line with his forward foot, again reaches his warning line with his rear foot. The fencers are not warned at any other location on the strip.

40 The competitor who, after a warning, crosses—i.e., crosses with both feet—the rear limit of the strip, is declared touched. However, if the fencer crosses the rear limit without having been warned, he is put back on guard at the warning line.

41 The ground must be used as many times as is necessary to allow each fencer the benefit of the full regulation length for retreating, but they will be warned only when they reach the warning line for the last time (see 302, 402).

42 If, after having crossed the rear limit, the fencer attacked parries and immediately ripostes ["tac-au-tac"] or makes a stop, or executes a stop with opposition, the touch thus scored is valid. This provision is not applicable to the fencer who crosses the rear limit of the strip for the last time (see 32, 38).

c) Lateral boundaries.

43 If a competitor crosses the lateral boundary of the strip with only one foot there is no penalty, but the Director must immediately give the command "Halt" and put the fencers back on guard on the strip.

The competitor who crosses one of the lateral boundaries with both feet is penalized. Upon the return on guard, his opponent will be advanced, from the position that he held at the moment of the action, by one meter in foil and by two meters in épée and sabre. The competitor who is placed beyond the rear limit of the strip with both feet by this penalty is declared touched, provided that he had already been warned at his warning line.

The fencer who crosses one of the limits with both feet to avoid being touched—particularly in making a flèche—will be penalized one touch, after a warning given in the course of the same bout (see 638).

d) Leaving the strip accidentally.

44 The competitor who crosses one of the limits as a result of an "accident" (such as a collision) is not liable to any penalty.

§ 11. Duration of the bout

45 By duration of the bout is meant effective duration, that is, the sum of the periods between the commands "Fence" and "Halt," not counting time used for deliberations of the jury or for other interruptions.

The duration of the bout is clocked exactly by a timekeeper appointed by the Organizing Committee (a provision that is mandatory for official

FIE competitions) (see 59).

For the finals of official competitions, as well as for all bouts which have a clock visible to the spectators, the clock shall be so located that it will be equally visible to each of the fencers on the strip.

The effective duration of a bout is:

- for one-touch epee: 5 minutes.
- in all weapons. for 4 touches = 5 minutes
- for 5 touches = 6 minutes
- for 8 touches = 10 minutes
- for 10 touches = 12 minutes

46 The Director, himself advised by the timekeeper (who must not call "Halt" or sound any signal), halts the fencing and advises the fencers that approximately one minute remains before the expiration of the time allowed for fencing. The touch started at the moment of the Director's "Halt" remains valid.

In cases of a prolonged interruption of the bout during this last minute, the fencers may, upon coming back on guard, be informed of the time remaining to them for fencing.

At the expiration of the regulation time, the timekeeper must call "Halt" (or sound a signal)—which stops the bout, and even an action already started is not valid.

47 In the finals of official FIE competitions, at the expiration of the regulation time the clock must automatically actuate a loud sound signal. Immediately upon the perception of this signal the bout is over, and even an action already started is not valid.

48 In the course of a bout, the Director may penalize by a warning, then by a touch, and then by exclusion from the competition, a fencer who improperly endeavors to create or prolong interruptions of the bout.

49 If the time expires before the bout is finished, the procedures to be followed are indicated for each weapon (see 226, 321, 414).

§ 12. Accidents—indispositions—withdrawal of a fencer

50 If a fencer is the victim of an accident that has been duly verified, the Director may allow him one single rest period of 20 minutes maximum, in order to put himself in condition to fence.* (See 647).

51 In case of one or several indispositions that have been duly verified, the Director may grant the fencer one single rest period of 10 minutes maximum in the course of the same team match, or the same pool, or during the bouts by direct elimination* (see 646).

52 The Director, on his own authority, may require the withdrawal of a fencer whose physical incapacity to continue is apparent (see 647).

* In the application of Articles 50 and 51, a cramp must be regarded as an indisposition and not as an accident and will fall under the provisions of Article 51.

CHAPTER VII—THE DIRECTION OF A BOUT AND THE JUDGING OF TOUCHES

A. OFFICIALS

§ 1. The Director ["Président"]

53 Every fencing bout is under the control of a Director whose duties are many:

- a) He calls the roll of the fencers (see 604, 615, 654).
- b) He directs the bout (see 63).
- c) He inspects the equipment, including the insulation of wires, particularly on the inside of the guard (see 18, 217, 314).
- d) He supervises his assistants (judges, floor judges, timekeepers, scorekeepers, etc.)
- e) He maintains order (see 615).
- f) He penalizes offenses (see 615).
- g) He awards the touches (see 67, 69, 75).

§ 2. The Jury: Judges and Floor Judges

54 The Director accomplishes his mission either with the assistance of four judges ["Assesseurs"], or with the aid of an automatic touch signalling machine. In the latter case he may have the assistance of two judges watching for the use of the unarmed hand or arm (see 31) or of two floor judges.

Floor judges are required when there is no metallic strip. For all bouts beginning with the quarter-finals, the Director must be assisted by two judges, each watching one of the fencers, with the function of signalling any use of the unarmed arm (see 30, 31):

- in foil, either to deflect the opponent's weapon, or to cover a part of the valid surface;
- in epee, to deflect the opponent's weapon.

In the latter weapon, they will also fulfill the functions of floor judges (see 30, 31, 71, 640).

The Director and the judges (or floor judges) form the "jury."

55 In accepting service on a jury, each of its members by so doing engages on his honor to respect the rules and to enforce them, as well as to perform his duties with the most scrupulous impartiality and the most sustained attention.

56 For the official competitions of the FIE, all members of the jury must be amateurs and licensed.

In other international competitions, the amateur members of a jury must be licensed.

57 They are appointed by the Directoire Technique (or in its absence by the Organizing Committee), which will select neutral juries as far as possible, and will select the Director from among the international Directors recognized by the FIE (see 512f).

58 For the finals of competitions for individuals that comprise at least six fencers, there will be, insofar as possible, two complete juries (or two Directors when judging with a scoring machine). (This pro-

cedure is mandatory for the official competitions of the FIE). (See 515).

§ 3. Auxiliary personnel

1. Scorekeepers and timekeepers

59 Whenever it is possible for them to do so, the organizers will appoint, on their own responsibility, scorekeepers who will be responsible for keeping the score sheet for the pool and the score boards, and a timekeeper who will be responsible for timing the duration of the bouts (see 45ff). (This provision is mandatory for the official competitions of the FIE).

2. Specialist personnel.

60 When the judging is being done with the aid of a machine for registering touches, the organizing committee will also appoint:

a) An operator for the machine:

The organizing committee must select qualified persons, who should attentively observe the working of the machine, in order to be able to report to the Director what the machine has signalled, and to warn him, even in the course of the bout, of any abnormal phenomenon.

When the fencing is going on, the operator must not touch the machine. When the fencing has stopped, he resets the machine, either after the Director has given a decision, or after tests of their weapons made by the fencers; but he must never in any case—after a phrase d'armes that has produced a signal—annul that signal before the Director has given his decision on it.

b) One or more experts [technicians]:

For each tournament, the organizing committee must assign qualified experts in electrical scoring equipment. These experts are under the supervision of the Directoire Technique.

The experts may be consulted, individually or collectively, by Directors or by the Directoire Technique on all questions relating to electrical scoring.

Members of the FIE Commission on Electrical Scoring and Equipment who are present are ex officio qualified as experts.

c. Repairmen

For every international event the Organizing Committee must ensure the presence of competent workmen to repair damage that may occur during the course of the competition to the personal electrical equipment of the competitors, and, when necessary, to repair the rest of the electrical equipment.

B. JUDGING BY A JURY.

§ 1. Duties of the Director

61 The Director will station himself at a distance from the strip that will permit him to follow the actions of the fencers thoroughly; he will follow their movements up and down the strip.

Using a microphone (preferably a wireless type) for [the finals of] official FIE competitions, he directs the bout according to the provisions of the rules (see 227ff, 322ff, 415ff).

§ 2. Location of the jury

62 On each side of the strip there are two judges, respectively to the right and left of the Director, and a little behind the fencers. The two judges on the Director's right watch the fencer on the Director's left, particularly to observe the materiality of touches that may be received by that fencer.

In similar fashion, the two judges on the Director's left watch the fencer on the Director's right, particularly to observe the materiality of touches that may be received by that fencer. (See, however, 69/4).

§ 3. Judging

a) Procedure

63 The Director, who alone is responsible for the direction of the bouts, gives the commands. However, another member of the jury may call "Halt," but only in case of an apparent or imminent accident. Similarly, the timekeeper stops the bout by calling "Halt" at the expiration of time.

64 As soon as a judge sees a material touch (valid or not) against the fencer he is particularly watching, he must raise his hand to advise the Director.

All judging is carried out aloud and without the members of the jury leaving their places.

65 The jury is not bound by the acknowledgement of a touch by a fencer, even when properly made (see 606).

66 The jury first determines the materiality of the touch or touches. The Director alone then decides which fencer is touched, by applying the conventional rules for each weapon.

b) Materiality of the touch

68 Immediately upon the stopping of the bout, the Director briefly analyzes the actions composing the last phrase d'armes before the "Halt" (this formality is not required in *épée*), and in the course of his analysis, he asks the two judges watching the same fencer to learn if, in their opinion, each of the actions thus analyzed by him has produced a touch against that fencer; then he does the same with the other two judges for the other fencer (these formalities are mandatory in all three weapons).

The judges, upon being questioned, must reply in one of the following ways: "yes," "yes, but on invalid surface [off-target]," "no," or "I abstain." The Director votes last.

69 The Director then adds the votes thus elicited on each side: the opinion of each judge counts as one vote and the Director's own opinion as a vote and a half, with abstentions not being counted:

1. If both judges on one side agree in a definite opinion (either both "yes" or both "no," or both "yes, but on invalid surface"), their judgment prevails.

2. If one of the judges has a definite opinion and the other abstains, the Director alone can decide, since his vote is preponderant; if he also abstains, the vote of the judge having a definite opinion prevails.

3. If the two judges have definite but contradictory opinions or if they both abstain, the Director may decide according to his own opinion;* if he also abstains, the touch is considered doubtful (see Para. 5 below).

* Examples: I — Judge A says "no"; Judge B says "yes, but off-target"; even if the Director believes it was a good touch the sum of the votes must be "no." But in this example, since one judge and the Director believe the point did make some contact with the

4. In case of a double abstention, the Director may, as an exception to the usual practice, ask the other two judges, if he believes that they were better located to see the touch—for example, when a fencer who has run past his opponent on a flèche has had a riposte aimed at his back.

5. A touch of doubtful materiality is never counted to the disadvantage of the fencer who may have received it; but, on the other hand, any touch made subsequently or simultaneously in the same phrase d'armes by the fencer who has benefited from this doubt must also be annulled (but see 38); as for a touch subsequently made by the fencer who had made the doubtful touch, it is necessary to distinguish:

I. — If the new touch (remise, redoublement, or riposte) is made by the fencer who had made the doubtful touch, without any intervening touch by his opponent, this new touch must be awarded.

II. — But if the doubt was as to the place where the touch arrived (one "yes" and one "yes, but off-target"), no further touch in that phrase d'armes can be awarded.

III. — The situation is the same if, between the doubtful touch and the new touch made by the same fencer, his opponent has also made a touch that has been annulled as doubtful.

c. Validity or priority of the touch

70 After the decision of the jury on the materiality of the touch, the Director, acting alone and by application of the rules conventional for each weapon, decides which fencer must be declared touched, or if they must both be (épée), or if no valid touch is to be awarded (see 232ff, 329ff, 416ff).

C. JUDGING WITH A SCORING MACHINE.

§ 1. Direction of the bout

71 1. The bout is under the control of the Director who must station himself so as to be able to follow the fencing while also being able to watch for the light signals.

2. At the beginning of each bout, the Director must inspect the weapons, uniforms and equipment of the fencers.

As for the weapons, and at each change of weapon, the Director, using a special weight, will verify the strength of the spring in the point; he will check on the insulation of the wires within the guard, and, for épée, will test the total travel and residual travel of the point by using metal blades 1.5 mm and 0.5 mm thick (see 18, 21, 719, 732).

3. The Director will superintend the proper functioning of the scoring machine. On his own initiative, or at the request of a team captain or of a fencer, he will have tests made to check out the scoring equipment and to locate any defects that may be found. He will prevent the fencers from complicating the testing by unplugging or untimely changing of their equipment.

4. If there are floor judges, they are located on each side of the Director, and on either side of the strip, and will follow the whole of the action (see 54).

opponent, all that followed in the phrase must be annulled after the decision "no."
 II. — Judge A says "yes"; Judge B says "yes, but off-target"; the Director abstains; he may not award a touch, since there is a question as to the place hit. Since both judges agree that there was a contact of the point with the opponent, all that followed in the phrase must be annulled after the decision "no."

5. The Director should consult the experts on electrical scoring equipment every time that he thinks it advisable (see 60/b).

§ 2. Judging

a) Materiality of the touch

72 The materiality of the touch is established according to the indications of the scoring machine, when necessary after consulting the floor judges (see 74).

Only the signals given by the scoring machine are authoritative in the judging of touches. In any case, the Director may not declare a fencer touched unless the scoring machine has regularly signaled the touch (except in case of penalties as provided in the rules) (see 228ff, 323ff, 626).

73 On the other hand, the Director should annul a touch signaled by the machine, in the cases set forth under each weapon (see 230ff, 325ff).

74 Only the two floor judges who each have one vote, and the Director, who has one and a half votes, decide if a touch has arrived on the ground or not. If they are unable to reach an affirmative decision by a majority (3 abstentions, or the 2 judges with contrary opinions and the Director abstaining), the touch must be considered doubtful (see 69/5). In any case, the Director may not take into account the opinions of any other persons.

b) Validity or priority of the touch

75 After his decision on the materiality of the touch, the Director, by application of the conventional rules for each weapon, declares which fencer must be considered touched, if they both must be (épée), or if no valid touch has occurred (see 232ff, 329ff, 416ff).

PART TWO: FOIL

CHAPTER I—HISTORICAL NOTE

The rules for foil were adopted on 12 June 1914 by the Commission on Foil of the FIE, meeting in Paris under the chairmanship of General G. Ettore, the representative of the Italian Fencing Federation, who was editor for the project.

In their essentials they reproduced the rules drawn up by Monsieur Camille Prevost, president of the Academie d'Armes and presiding officer of the technical division for foil of the French National Fencing Federation. They likewise were in agreement with the rules drawn up by the Marquis de Chasseloup-Laubat for "Les Armes de France," with various earlier international rules promulgated by different countries affiliated with the FIE, and with the Franco-Italian rules.

The present rules only define and complete those adopted in 1914.

The rules governing foil competitions fenced with the aid of electrical touch scoring machines were adopted in 1957, and have since been modified by different Congresses subsequent to that date.

CHAPTER II—FIELD OF PLAY ["TERRAIN"]

(See 14ff.)

201 Foil competitions are fenced indoors on strips made of wood, linoleum, cork, rubber, plastic, etc.

At competitions judged with electrical scoring machines, the strip and its extensions are completely covered with metal, metallic mesh, or a material with a metallic base, in order to prevent the registering of touches on the floor. (This provision is mandatory for the official FIE competitions.) (See 711.)

202 The width of the strip is from 1.8 to 2.0 meters. The length of the strip is 14 meters, so arranged that each competitor, being placed at 2 meters from the center line, will have at his disposal for re-treating, without crossing the rear limit with both feet, a total distance of 5 meters (see 15, 38ff, and the drawing on page 16).

203 Seven clearly visible lines are drawn on the strip, perpendicular to its length, thus:

—1 **center line** (which may be replaced by a central point or by a special mark at the edge of the strip);

—2 **on-guard lines**, located two meters on each side of the center line (these must be drawn across the full width of the strip);

—2 **rear limit lines**, which must be drawn across the full width of the strip, at a distance of seven meters from the center line if possible; if sufficient ground is not available, the distance may be shorter, but not less than five meters (see 15);

—2 **warning lines**, drawn one meter in front of each rear limit (these may be drawn only 30 centimeters inward from the edges of the strip).

When a fencer has reached his warning line with his rear foot, the Director gives the command "Halt" and warns this fencer about the ground remaining to him before he crosses the rear limit of the strip (see 39/b).

204 The table on which the scoring machine is placed must be located at least one meter from the strip, facing the center line; the Director must watch that its isolation is respected by auxiliary personnel as well as by fencers and spectators. In principle, the same table may not be used by the scorekeepers, timekeepers, etc.

CHAPTER III—EQUIPMENT OF FOIL FENCERS

(Weapons — Other Equipment — Clothing)

A. WEAPONS (see 16ff, 22ff).

§ 1. General specifications for the foil

a) Weight

205 The total weight of a foil ready to use is less than 500 grams.

b) Length

206 The maximum total length of a foil is 110 centimeters.

c) Blade

207 The blade is made of steel; its cross-section is quadrangular. It is mounted with the larger surface placed horizontally.

The maximum length of the blade is 90 centimeters (see 24).
The blade must display a flexibility corresponding to a bend of 5.5 centimeters minimum and 9.5 cm maximum measured in the following fashion:

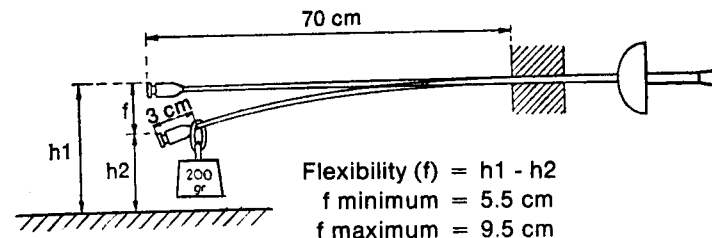

1. The blade is fixed horizontally at a point 70 cm from the extremity of the button.

2. A 200 gram weight is suspended from the blade, at 3 cm from the extremity of the button.

3. The bend is measured at the extremity of the button as the distance between the unweighted and weighted positions.

All work performed upon a blade with the intention of changing its flexibility, whether by grinding, filing, or any other method, is prohibited (see 22).

d) Guard (see 26)

208 The guard must be able to pass through a straight cylindrical tube (gauge) 12 centimeters in diameter and 15 centimeters long.

Eccentric mounting is not permitted; that is, the blade must pass through the center of the guard.

e. Martingale

209 When the foil is not secured to the hand by an attachment of some sort or by the body wire, the use of a martingale is mandatory.

f. Buttons and points

210 In the absence of an electrical scoring point (or of some other type, approved in advance), the foil must be capped, i.e., the flat metal top which terminates the blade must be enclosed in waxed thread, or in plastic, or in some other non-metallic material.

§ 2. Specifications for the electrical foil

211 In addition to the special requirements regarding construction mentioned in Part SEVEN (see 702, 712, 718), the electrical equipment of foil fencers must meet the following conditions:

a) Point

The pressure that must be exerted upon the point to cause the scoring machine to register must be more than 500 grams, i.e., the spring in the button must be able to push back this weight (see 719).

The travel of the point necessary to cause a signal may be infinitely small; the total travel is less than one millimeter.

Sharpening the point or its edges is prohibited.

SPECIFICATIONS COMMON TO ALL FOILS (Articles 24, 25)

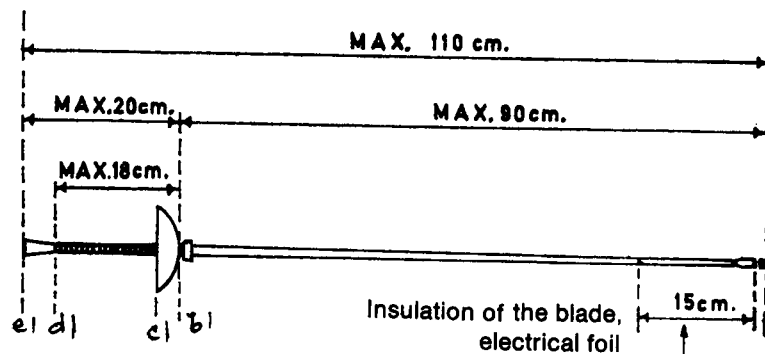

Insulation of the blade,
electrical foil

(Article 211)

Fig. 1. Dimensions of the foil.
(Articles 206, 207)

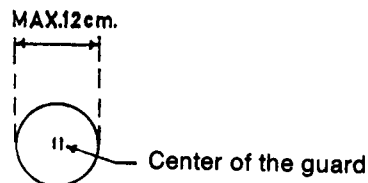

Fig. 2. The guard. (Article 208)

Article 205. The total weight of the foil must be less than 500 grams.

b) Insulation

The body of the button, except such parts as may be insulated, and the foil blade to a distance of 15 centimeters from the button, as well as the pommel or the extremity of the handle, must be entirely covered with some insulating material (insulating tape, adhesive tape, or varnish) (see 721).

B. CLOTHING AND EQUIPMENT

§ 1. General specifications for clothing and equipment for all foil fencers

a) Jacket

212 The lower edge of a jacket that is cut horizontally at the waist must overlap the trousers by at least 10 centimeters when the fencer is in the on-guard position (see 27).

The jacket must include an underarm lining doubling the sleeve down to the inside of the elbow [of the sword arm] and the flank in the area of the armpit.

In addition, the wearing under the jacket of a protective undergarment of hemp cloth, nylon, etc., is obligatory. It must:

1. have at least two thicknesses of material.
2. include a sleeve down to the inside of the elbow [of the sword arm], without opening or seam in the area of the armpit.
3. offer the best guarantees of safety.

It may be attached to the jacket, without being entirely sewn to it.

b) Glove

213 The glove may be lightly padded (see 27).

c) Mask (see 27, 722/4)

214 In foil, the mask has a shape such that the bib does not come down more than two centimeters below the collar, measured when the fencer is on guard, and in any case not below the points of the collar bones (clavicles).

d) Clothing of women fencers

215 The clothing of women fencers includes knickers closed below the knee or a divided skirt, and, in the jacket, a breast protection of metal or some rigid material (see 27).

§ 2. Specifications for clothing and equipment necessary for electrical foil

a) Metallic vest

216 The fencer wears over the jacket a metallic vest ("plastron"), the conductive surface of which must entirely cover the valid surface without omission (see 220), both in the on-guard position and in the lunge.

Whatever method of closure is used, the metallic cloth must be overlapped sufficiently to ensure coverage of the target in all positions; the side forming the overlap must be that of the sword arm.

The metallic cloth collar of the vest must have a minimum height of three centimeters.

The lamé cloth must meet the specifications laid down for testing (see 722).

The shape of the vest toward the bottom shall be such that when the vest is stretched out flat, two straight lines will join the points corresponding to the top of each hip bone to the corresponding point at the junction of the groin.

The band of cloth, non-metallic, that passes between the legs must be at least three centimeters wide (see drawing).

b) Body wire and connectors

217 The conductors of the body wire (fencer's personal equipment) will be well insulated electrically between themselves, will not be susceptible to humidity, and will be connected or twisted together along their length. This body wire is terminated at each end by a connector plug:

—at the reel end, a male 3-pin plug answering the conditions of manufacture and assembly specified in Part SEVEN (see 710, 717), and connected to the wires in the following manner:

—pin 15 mm from the center: to the metallic vest

—central pin: to the wire in the foil

—pin 20 mm from the center: to the metal of the weapon and the metallic strip.

The wire connecting the rear plug of the body wire to the crocodile clip for attachment to the metallic vest must have a free length of at least 40 cm. This wire must be soldered to the crocodile clip and this solder joint must not be covered by insulation or any other material whatsoever.

The crocodile clip must be a strong type and guarantee perfect contact with the metallic vest.

—at the foil end, inside the guard, the choice of a system of connection is optional, but in any case the system chosen must meet the conditions of Article 712.

Furthermore, in no case may the male pins of the plug be able to touch the metal of the guard. The wire coming from the point of the foil will be protected by an insulating sleeve from the spot where it enters the guard to the insulated support socket for the plug. In any case, the uninsulated wire may not extend beyond the socket. (See 26, 208, 712).

c) Mask

218 The mesh of masks will be insulated inside and outside, before any assembly, by a shock-resistant plastic material (see 722).

CHAPTER IV—THE CONVENTIONS OF FENCING WITH THE FOIL

A. METHOD OF MAKING TOUCHES

219 The foil is a thrusting weapon only. An offensive action with this weapon must therefore be made with the point, and only with the point. Every thrust with the point must arrive cleanly and plainly to be counted as a touch (see 29).

B. VALID SURFACE [TARGET]**§ 1. Limitation of the valid surface**

220 In foil, only those touches that reach a surface classified as valid [the target] are counted.

The valid surface, in both women's and men's foil, excludes the limbs and the head. It is limited to the trunk of the body, reaching at the top to the upper edge of the collar to a height of six centimeters above the top of the collar bones (clavicles); at the side, it reaches the seams of the sleeves, which should pass over the top of the humerus; at the bottom, it follows a line that passes horizontally across the back at the level of the top of the hip bones, and from there proceeds in front by straight lines to the junction of the groin (see drawing).

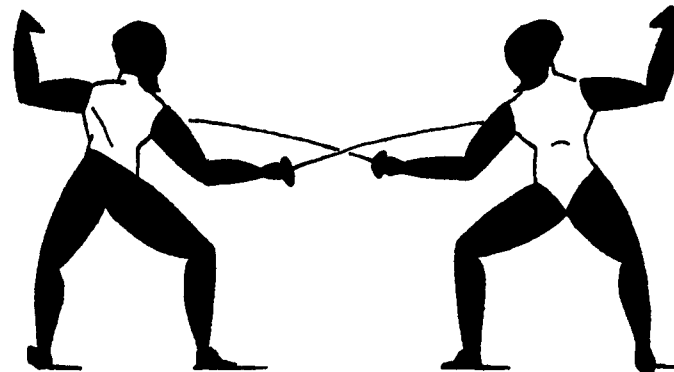

Valid Surface [target] in foil, men and women

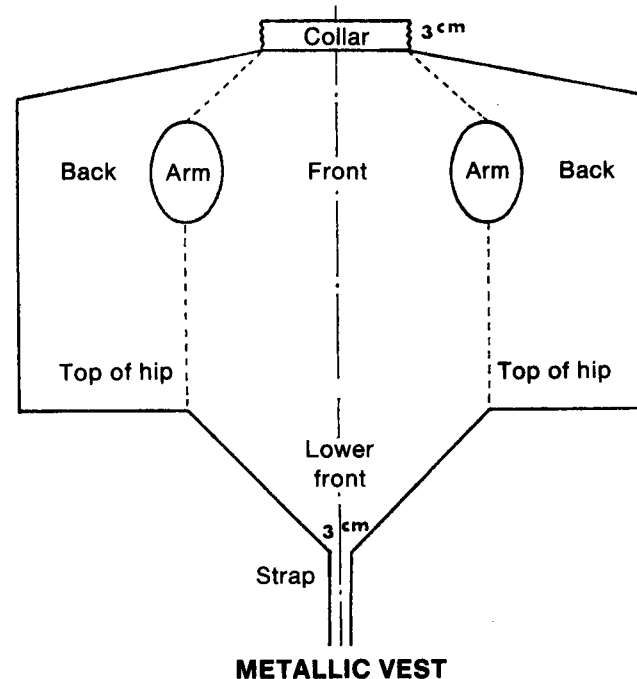

221 The bib of the mask is not part of the target (see 214).

§ 2. Extension of the valid surface

222 Touches arriving on a part of the body classified as invalid are counted as valid when, by an abnormal position, the fencer has substituted this invalid surface for a valid surface.

§ 3. Invalid surface

223 A touch that arrives on an invalid surface (whether directly or as the result of a parry) is not counted as a valid touch, but stops the phrase d'armes and thus annuls all subsequent touches (but see 222).

C. CORPS A CORPS AND FLECHES

224 Whenever, in foil, a fencer intentionally or systematically causes the corps à corps (even with neither brutality nor violence), he must be penalized one touch—after a warning given in the course of the same bout (see 34, 37, note to 318, and 641).

D. NUMBER OF TOUCHES — DURATION OF THE BOUT

225 In foil, bouts are fenced for five touches for men and four touches for women, with durations, respectively, of six minutes and five minutes per bout; in direct elimination, there will be two bouts of five or four touches, with a deciding bout if necessary, or a bout for a specified number of touches (see 551f, 559).

226 When the time runs out before the bout is decided:
a) if one of the competitors has received more touches than the other, there is added to his score the number of touches necessary to arrive at the maximum, and the same number is also added to the score of the other fencer;

b) if the two fencers are tied, they are both regarded as having received the maximum number of touches, less one; and they fence without limit of time for the last touch. They are put back on guard at the positions they occupied when the bout was interrupted (see 32).

E. JUDGING TOUCHES IN FOIL

227 Foil competitions are judged with the aid of an electrical scoring machine. This provision is mandatory for official FIE competitions. For other competitions, the organizers are obliged to announce in advance if the competition will be judged by a jury (see 1f).

I. MATERIALITY OF THE TOUCH

§ 1. With a jury

(See 61ff).

§ 2. With a scoring machine

228 1. For judging the materiality of the touch, the indication of the scoring machine alone is the determinant. In any case, the Director

may not declare a fencer touched unless the machine has properly registered the touch (except in case of penalties provided in the rules) (see 72, 626).

229 In using the scoring machine, note that:
a) if the two signals on the same side (both white and colored) are lit, the invalid touch preceded the valid touch;

b) otherwise, the machine does not indicate whether there was any priority in time between two or more touches that it registers at the same time.

230 2. The Director will disregard signals resulting from thrusts:
—started before the command "Fence" or after the "Halt" (see 32).

—touching the ground (outside the metallic strip or when there is none), or touching any object whatsoever other than the opponent or his equipment (see 73f).

The fencer who intentionally causes a touch signal by putting his point on any surface whatsoever other than his opponent, shall be penalized one touch—after a warning given in the course of the same pool, the same team match, or during the bouts by direct elimination.

It is forbidden for a fencer to put an uninsulated part of his weapon in contact with his metallic vest with the intention of blocking the operator of the machine and thus avoiding being touched.

The penalty for this violation is the annulment of a touch that may have been scored by the fencer who creates the blocking of the machine.

In case of a repetition, the penalty is annulment of the touch that may have been scored and—after a warning valid for the whole pool, the whole team match, or the bouts by direct elimination—the penalty of one touch.

In case of another repetition, the penalty is exclusion from the competition (see 648/b).

231 3. The Director, on the other hand, must take into account possible defects in the scoring equipment, particularly:

a) He must annul the touch he has just awarded, as the result of the appearance of a valid touch signal (colored lamp), if he establishes, by tests carried out under his careful supervision, and before any effective resumption of the bout* and without anything having been changed in the equipment in use (see 71/3 to 5):

—either that a "valid" touch signal is produced against the fencer declared touched without there actually being a valid touch;

—or that an invalid touch made by the fencer declared touched is not registered by the machine;

—or that a valid touch made by the fencer declared touched produces no signal, either valid or invalid;

—or that touch signals produced by the fencer declared touched do not remain fixed on the machine.

b) On the other hand, when the Director has determined that one fencer's touch had the priority [right of way], there is no ground for annulling that touch if tests then show that a valid touch made by the fencer declared touched is registered as invalid or that the latter's weapon gives a permanent invalid signal.

* The fact that the Director has said "Fence," and even that a certain time has elapsed since that command, does not necessarily indicate an "effective resumption of the bout," if the fencers have remained in a passive attitude. It is necessary that the two fencers have actually entered into a phrase d'armes that might have affected the equipment in use.

c) If a fencer's equipment does not conform to the specifications in paragraphs 2 to 4 of Article 722, there is no ground for annulment in case a valid signal is produced by a touch on his invalid surface.

4. The Director must also apply the following rules:

a) only the last touch preceding the establishment of a defect can be annulled;

b) the fencer who, without being asked by the Director, has made modifications in, or has changed, his equipment before the Director has given his decision, loses all right to annulment of a touch (see 71/3);

c) if there has been an effective resumption of the bout (see note to paragraph 3/a above), a fencer may not claim the annulment of a touch awarded against him before the said resumption;

d) the localization of a defect found in the equipment (including the fencers' own equipment) is of no consequence for this possible annulment;

e) it is not necessary that the defect found should repeat itself at every test; but it is necessary that it have been positively observed at least once by the Director himself, in the course of tests made by him or under his supervision;

f) the sole fact that the fencer declared touched has broken his blade is not sufficient to annul that touch;

g) the Director must be especially alert for touches that are not signalled, or abnormally signalled, by the machine. In case of repetition of these defects, the Director must call for the member of the Commission on Electrical Scoring and Equipment who is present, or for the technical expert on duty, in order to determine whether the equipment conforms to the rules.

The Director must watch that nothing is changed, either in the fencers' equipment, or in the whole of the electrical equipment, before the inspection by the expert.

5. In all cases in which the verification has been made impossible as the result of accident, the touch will be regarded as "doubtful" (see 69/5).

6. If signals appear on the apparatus simultaneously from both sides and the Director cannot establish the priority [right of way] with certainty, he must put the fencers back on guard.

7. In application of the general rule (see 32), even if no signal has been registered, the Director must halt the bout as soon as the action becomes confused and it is no longer possible for him to analyze the phrase d'armes.

8. The Director must also watch the condition of the metallic strip; he will not permit the bout to be started or to be continued if the metallic strip has holes capable of interfering with the registration of touches. (The organizers shall make provision for the rapid repair or replacement of metallic strips.)

II. VALIDITY OR PRIORITY OF THE TOUCH [RIGHT OF WAY]

§ 1. Preliminary note

232 Whatever means the Director has used to reach a decision on the materiality of the touch (with the assistance of a jury or by aid of a scoring machine), it is then his responsibility alone to decide on the subject of the validity or priority [right of way] of the touch, by applying the following principles which are the conventions proper to foil fencing.

§ 2. Observance of the phrase d'armes (fencing phrase)

233 a) Every correctly executed attack (see 10) must be parried or completely avoided, and the phrase d'armes must be followed through.

To judge the correctness of an attack, the following points must be considered:

1. if the attack starts when the opponent is "in line" (i.e., "with the arm extended and the point threatening a valid surface"), the attacker must first deflect his adversary's weapon;*

2. if the attack starts when the opponent is not in line, it may be executed either by a direct thrust or by a disengagement, or by a cutover (coupé), or may be preceded by effective feints that force the opponent to parry;

3. if, in searching for the opposing blade to deflect it, the blade is not found (derobement or trompement), the right of way passes to the opponent.

234 b) The parry gives the right of way to the riposte; the simple riposte may be direct or indirect, but to annul any subsequent action of the attacker, it must be executed immediately, without indecision or delay.

235 c) In a composite attack, if the opponent finds the blade on one of the feints, he has the right to riposte.

236 d) In composite attacks, the opponent has the right to make a stop; but to be valid the stop must precede the conclusion of the attack by a period of fencing time, i.e., the stop must touch before the attacker has commenced the last movement of the conclusion of the attack.

§ 3. Judging

237 In applying these fundamental conventions of the foil, the Director must judge as follows:

Whenever, in a phrase d'armes, the fencers are both touched simultaneously, there has been either a simultaneous action or a double touch.

The former is the result of simultaneous conception and execution of the attack by both fencers; in this case, the touches given are annulled for both fencers, even if one of them has touched an invalid surface.

The double touch, on the contrary, is the result of a faulty action on the part of one of the fencers.

Consequently, if there is not a period of fencing time between the two touches:

1. The fencer attacked is alone counted as touched—

a) if he makes a stop into a simple attack;

b) if, instead of parrying, he attempts to avoid being touched, and fails;

c) if, after a successful parry, he pauses for a moment—which gives his opponent the right to resume his attack (redoublement, remise, or reprise);

d) if, on a composite attack, he makes a stop without having the advantage of a period of fencing time;

e) if, being in line (arm extended and point threatening a valid surface), after a beat or a taking of the blade which deflects his weapon, he attacks or replaces his blade in line instead of parrying a direct thrust made by the attacker.

* Directors must be alert that the mere grazing of the blades is not considered as sufficient to deflect the opponent's blade.

2. The attacker alone is counted as touched—

- a) if he starts his attack when the opponent is in line (arm extended and point threatening a valid surface) without deflecting the opposing blade;*
- b) if he attempts to find the blade and fails (because of a derobement or trompement) and still continues the attack;
- c) if, in a composite attack, in the course of which his opponent finds the blade, he continues the attack while his opponent immediately ripostes;
- d) if, in a composite attack, he hesitates for a moment during which the opponent delivers a stop thrust, yet he continues his attack;
- e) if, in a composite attack, he is hit by a stop made with the advantage of a period of fencing time before his conclusion;
- f) if he touches by remise, redoublement, or reprise, after a parry by his opponent which is followed by an immediate simple riposte executed in one period of fencing time and without withdrawal of the arm.

3. The fencers are replaced on guard, every time that the Director cannot decide clearly which side is at fault in a double touch.

One of the most difficult cases to decide occurs when there is a stop and there is doubt as to whether it had a sufficient time advantage over the conclusion of a composite attack. In general, in this case, the double touch is the result of simultaneous faults by the fencers, which fact justifies the replacement on guard. (The fault of the attacker lies in indecision, slowness or inefficient feints; the fault of the fencer attacked lies in his delay or slowness in making the stop).

PART THREE: EPEE**Note on the present set of épée rules:**

The few differences that exist between the rules used with electrical scoring machine and those in effect for non-electrical épée are printed in this part in a heavy type face.

CHAPTER I—HISTORICAL NOTE

The épée rules published in 1914 defined and completed all the sets of épée rules which existed before the founding of the FIE, and which had been adopted since 1892 in France and elsewhere, particularly those of:

The permanent committee of the Société d'Escrime à l'Épée de Paris; the Académie d'Épée; and Société d'Entraînement à l'Escrime et au Pistolet; and the Armes de France;

The international committee of 1905 (subject to the laws of each country on matters applicable to duelling);

The Union des Sociétés Françaises de Sports Athlétiques (USFSA);

The Comité National des Sports de France;

The Comité Olympique Français;

The organizing committees for tournaments held at Nice and the Côte d'Azur, at Ostend, etc.

* Directors must be alert that a mere grazing of the blades is not considered as sufficient to deflect the opponent's blade.

The present rules only modify in details the principles set forth in 1914. The rules governing épée competitions fenced with electrical scoring apparatus were adopted in 1936 and have been modified by different Congresses subsequent to that date.

CHAPTER II—FIELD OF PLAY ["TERRAIN"]

(See 14ff).

301 Épée competitions may be held indoors or in the open air. The official FIE competitions may be held only indoors.

302 The width of the strip is from 1.8 to 2.0 meters, and its length is 18 meters. If for practical reasons the length of the strip must be set at 14 meters [as is customary], each fencer will be given enough ground so that, being put on guard 2 meters from the center line, he has 7 meters for retreat before he crosses the rear limit of the strip with both feet (see 15, 38ff, and the plan on page 16).

303 Seven clearly visible lines are drawn on the strip, perpendicular to its length, thus:

—1 center line (which may be replaced by a central point or by a special mark at the edge of the strip);

—2 on-guard lines, located two meters on each side of the center line (these must be drawn across the full width of the strip);

—2 rear limit lines, which must be drawn across the full width of the strip, at a distance of 7 meters from the center line; if sufficient ground is not available, the distance may be shorter; this distance may not, however, be less than 5 meters (see 15);

—2 warning lines, drawn two meters in front of the respective rear limits (these may be drawn only 30 cm inward from the edges of the strip).

When a fencer has gone beyond the rear limit of the strip with both feet [on a 14 meter strip], he is replaced on guard with his rear foot on the warning line; he is declared touched if he again crosses over the rear limit with both feet (see 39/b).

304 For competitions judged with electrical scoring machines, the strip and its extensions are completely covered with metal, or metallic mesh, or some material with a metallic base, in order to prevent the registration of touches that land on the floor (this provision is mandatory for the official FIE competitions) (see 711).

305 The table on which the scoring machine is placed must be located at least one meter from the strip, facing the center line; the Director must watch that its isolation is respected by auxiliary personnel as well as by fencers and spectators. In principle, the same table may not be used by the scorekeepers, timekeepers, etc.

CHAPTER III—EQUIPMENT OF EPEE FENCERS

(Weapons — Other Equipment — Clothing)

(See 16ff).

A. WEAPONS (see 22ff)

§ 1. General specifications for the épée

a) Weight

306 The total weight of the épée ready for use is less than 770 grams.

b) Length

307 The maximum total length of the épée is 110 centimeters.

c) Blade

308 The blade is made of steel, its cross-section is triangular without cutting edges. It shall be as straight as possible; it is mounted with the groove uppermost. Any curve in the blade must in any case be less than one centimeter and can be allowed only in the vertical plane.

The maximum length of the blade is 90 centimeters.

The maximum width of any one of the three sides of the blade is 24 millimeters.

The blade must display a flexibility corresponding to a bend of from 4.5 centimeters minimum to 7.0 centimeters maximum, measured in the following fashion:

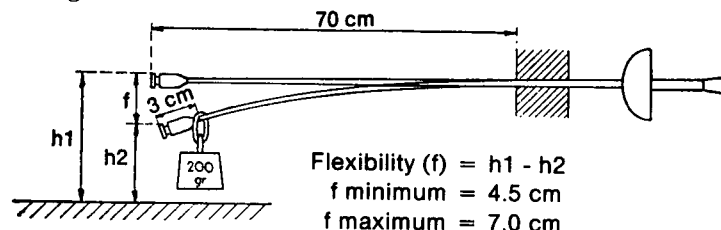

1. The blade is fastened horizontally at a point 70 centimeters from the extremity of the button.

2. A 200 gram weight is suspended from the blade at a point 3 centimeters from the extremity of the button.

3. The bend is measured at the extremity of the button between the unweighted and weighted positions (see drawing).

4. All work performed upon a blade with the intention of changing its flexibility, whether by grinding, filing, or any other method, is prohibited (see 22).

d) Martingale

309 When the épée is not secured to the fencer's hand by an attachment of some sort or by the body wire, the use of a martingale is mandatory.

e) Guard (see 26)

310 The guard must have a circular edge and be able to pass through a cylinder (gauge) 13.5 centimeters in diameter by 15 centimeters long.

The depth of the guard (distance between planes b and c) must fall between 3 and 5.5 centimeters (see 24).

The total length between planes a and c may never exceed 95.5 centimeters (see 24).

Eccentric mounting (the distance between the center of the guard and the point where the blade passes through the guard) is permitted if it does not exceed 3.5 centimeters.

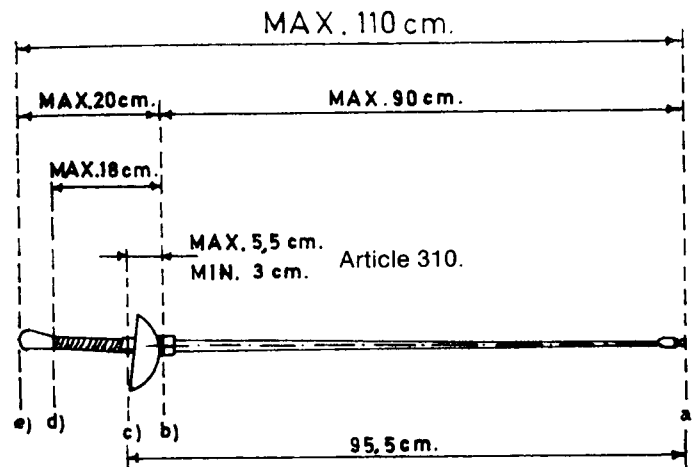

Fig. 1. Dimensions of the épée.
(Articles 307 and 308)

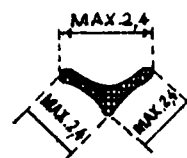

Fig. 2. Section of the blade.

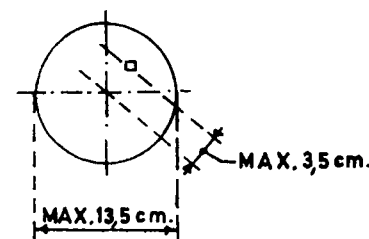

Fig. 3. Offset of the guard.
(Article 310)

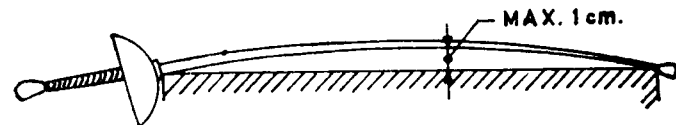

Fig. 4. Bend of the épée blade.
(Article 308)

§ 2. Point and button

a) For electrical épée

311 1. The electrical button ends in a point which must meet the specifications set forth in Part SEVEN (see 732).

2. Sharpening the point or its edges is prohibited.

3. The button must be fastened to the end of the blade according to the specifications set forth in Part SEVEN (see 733).

4. The pressure that must be exerted on the point to cause the scoring machine to register must be more than 750 grams, i.e., the spring in the button must push back this weight (see 732).

5. The travel of the point necessary to close the circuit of the épée and thus cause the machine to register, called the "lighting stroke," must be greater than 1 millimeter. The additional travel of the point, called the "residual travel," must be less than 0.5 millimeter—this provision is just as important as that for the lighting stroke. The total travel must be more than 1.5 millimeters (see 18 and 732).

b) For non-electrical épée

312 1. If the *pointe d'arrêt* is screwed onto the blade, the procedure must meet the specifications for electrical épées (see 733).

2. Otherwise, it must be fastened to the flattened surface (of 6 millimeters minimum diameter) that terminates the blade, by means of waxed thread; and in this case its prongs, which must be parallel, may not extend more than 2 millimeters beyond the thread.

B. EQUIPMENT

§ 1. Mask

313 The mask may not be covered, either wholly or in part, by a material that can make the point glance off (see 27).

§ 2. Body wire

314 The conductors of the body wire (fencer's personal equipment) will be well insulated electrically among themselves, will not be susceptible to humidity, and will be connected or twisted together along their length.

The body wire is terminated at each end by a connector plug:

—At the reel end, a male 3-pin plug will be connected to the wire in the following manner:

—pin 15 mm from the center: to the epee wire most directly connected to the point;

—center pin: to the other epee wire;

—pin 20 mm from the center: to the metal of the weapon and the metallic strip. This plug must meet the specifications for manufacture and assembly set forth in Part SEVEN (see 710 and 717).

—Inside the guard the choice of a system of connection is optional, but in any case the system chosen must meet the conditions of Article 712.

Furthermore, in no case may the male pins of the plug be able to touch the metal of the guard.

The two wires coming from the point will be protected by two insulating sleeves, one for each wire, from the spot where they enter the guard up to

the two insulated sockets of the connector. In any case the uninsulated wires must not extend beyond the sockets (see 26, 310, 712, 730).

C. CLOTHING

315 The jacket must cover the whole of the front of the trunk, and will be completed by a lining in two parts, one doubling the sleeve down to the inside of the elbow of the sword arm, the other protecting the flank in the area of the armpit. The collar must have a minimum height of 3 centimeters.

In addition, the wearing under the jacket of a protective undergarment made of hemp cloth, nylon, etc., is mandatory. It must:

—have at least two thicknesses of material;

—include a sleeve down to the inside of the elbow of the sword arm, and have no openings or seam in the area of the armpit;

—offer the best guarantees of strength (see 27).

It may be attached to the jacket without being completely sewn to it.

CHAPTER IV—CONVENTIONS OF EPEE FENCING

A. MANNER OF MAKING TOUCHES

316 The épée is a thrusting weapon only. An offensive action with this weapon must therefore be made with the point, and only with the point.

Every thrust with the point must arrive cleanly and plainly to be counted as a touch (see 29).

Fencers are forbidden to drag their points along the metallic strip: every violation will be punished under the provisions of Article 657.

B. VALID SURFACE [TARGET]

317 In épée, the valid surface includes the fencer's whole body, including his clothing and equipment.

Thus every touch that arrives is counted, whatever part of the body (trunk, limbs, or head) or of the clothing or of the equipment it reaches (see illustration).

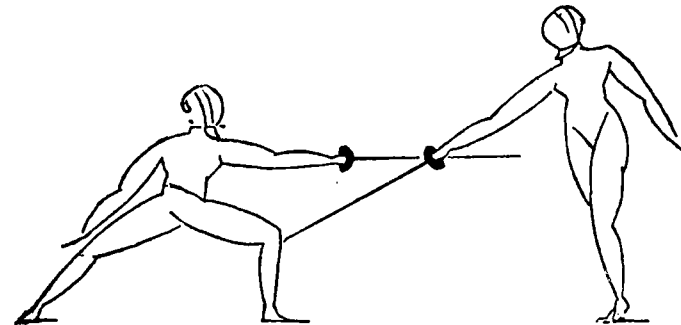

Valid Surface [target] in épée

C. CORPS A CORPS AND FLECHES

318 In *épée*, the competitor who, whether by *flèches* or by determined advances, causes the *corps à corps* (without either brutality or violence), even several times in succession, has not violated the fundamental conventions of fencing and is guilty of no irregularity (see 34, 37).*

D. NUMBER OF TOUCHES—DURATION OF THE BOUT

319 Bouts in *épée* are for 5 touches, with a 6 minute time limit per bout; in direct elimination, there will be two bouts for 5 touches, with a deciding bout if necessary, or a bout for a specified number of touches (see 55f, 559).

320 If, as the result of a double touch, both fencers have received the maximum number of touches in the bout, they must fence for one or more additional touches, up to the time limit. Every new double touch will be annulled (and the fencers will therefore hold their places on the strip). The score of such a bout will always be entered with the maximum number of touches against each fencer, for example, in a five touch bout, the result will be entered on the score sheet as D-5 and V-5 (see 321/b).

321 If the time limit is reached before the bout is decided:
a) in one touch, both fencers are declared touched and each is charged with a defeat.

b) In several touches:
—if one of the fencers has received more touches than the other, there will be added to his score the number of touches necessary to reach the maximum, and the same number will be added to his opponent's score;
—if the opponents have the same number of touches (or no touches), they are both regarded as having received the maximum number of touches and are each charged with a defeat, except in direct elimination, when the bout will be extended without limit of time, until a result is reached (see 552).

E. JUDGING TOUCHES IN EPEE

322 *Épée* competitions are judged with the aid of an electrical scoring machine (this provision is mandatory for the official FIE competitions).

I. MATERIALITY OF THE TOUCH**§ 1. Fundamental rule**

323 For judging the materiality of the touch, the indication of the scoring machine alone is the determinant. In any case, the Director may not declare a fencer touched unless the machine has properly registered the touch (except in case of penalties provided in the rules) (see 72, 626).

* The "fleche ending systematically in a *corps a corps*" mentioned in this Article must not be confused with the "fleche ending in a shock jostling the opponent," which, in all three weapons, is regarded as an act of willful brutality and is punished as such (see 645).

On the other hand, the "fleche made by running past the opponent" and without a *corps a corps* is not prohibited: the Director must not call "Halt" too soon, in order not to cut off a possible *riposte*; if in executing this fleche without having scored on his opponent, the fencer who makes the fleche systematically crosses over the lateral boundaries of the strip, he must be penalized as set forth above (see 43).

§ 2. Annulment of touches

324 1. In his judging, the Director will disregard touch signals:
—resulting from thrusts started before the command "Fence" or after the "Halt" (see 32);
—produced by the meeting of the points, or by a point touching the ground (outside the metallic strip or when there is none), or by touching any object whatsoever other than the opponent, including his equipment (see 74, 331).

325 The fencer who intentionally causes a touch signal by putting his point on any surface whatsoever other than his opponent, shall be penalized one touch—after a warning given in the course of the same pool, the same team match, or during the bouts by direct elimination (see 74).

326 2. In addition, the Director must take into account possible defects in the electrical equipment and annul the last touch registered, in the following cases:

a) if the point landing on the guard of the fencer who was indicated as touched, or on the metallic strip, causes the machine to register;

b) if a touch regularly made by the fencer who was indicated as touched does not cause the machine to register;

c) if the machine registers a touch signal improperly against the fencer who was indicated as touched, for example, as the result of a beat on the blade, or of some movement of his opponent, or of vibrations transmitted from the floor to the scoring machine, or as the result of any cause other than a proper touch;

d) if the registration of a touch made by the fencer who was indicated as touched:

—does not prevent the indication of a subsequent touch made by his opponent after a time longer than that allowed for a double touch;

—or is annulled [by the signal lamp switching off] by a subsequent touch made by the opponent.

327 3. The Director must also apply the following rules concerning the annulling of touches:

a) only the last touch registered before the establishment of the defect can be annulled, and then only if the fencer against whom it was signalled is the one put at a disadvantage by this defect.

b) The defect must be demonstrated by tests carried out under the supervision of the Director immediately after the interruption of the bout and without anything whatsoever being changed in the equipment in use.

c) In these tests, the Director should not try to reconstruct what actually happened in the course of the bout; it is only necessary to establish whether there was a real possibility of an error in the judgment resulting from a defect. The localization of this defect in the whole of the electrical equipment (including the personal equipment of one or the other of the fencers) is of no importance in arriving at this decision.

d) The fencer who, without being asked to do so by the Director, proceeds to make modifications in, or to change, his equipment, before the decision has been given, loses his right to annulment (see 71/3). In the same fashion, after the fencers are put back on guard and the bout has

effectively been resumed,* a fencer may no longer claim the annulment of a touch that was indicated against him before the said resumption.

e) it is not necessary, for the annulment of a touch, that the defect found should repeat itself on every test made, but it must have been verified at least once, beyond any doubt, by the Director.

f) if the occurrences described in Article 326 were produced by the unplugging of the fencer's body wire (either within the guard or at his back), they do not constitute grounds for annulment of the touch registered.

However, if the safety device specified by Article 710 is not working or is missing, the annulment must be granted if the disconnection is at the fencer's back.

g) the fact that a fencer's *épée* displays, on the guard or the blade or elsewhere, more or less extensive non-conductive areas caused by oxidation (rust), glue, paint, or any other material, on which his opponent's touches may produce a signal, does not provide a reason for annulment of touches signalled against that fencer.

h) the fact that the fencer who has been indicated as touched is found to have broken his blade is sufficient ground for annulment of the touch scored against him, unless the breaking of the blade clearly happened after the registration of the touch.

i) in case a fencer tears the metallic strip by a touch to the ground, and at the same time the touch signal is registered against his opponent, that touch must be annulled.

j) in every case which verification is impossible because of an accident, the touch will be considered doubtful and annulled (but see 331).

k) the Director must be especially alert for touches that are not signalled, or abnormally signalled, by the machine. In case of repetition of these defects, the Director must call on the members of the Commission on Electrical Scoring and Equipment who are present, or on a technical expert on duty, in order to determine whether the equipment conforms to the rules.

The Director must watch that nothing is changed, either in the fencers' equipment, or in the whole of the electrical equipment, before the inspection by the expert.

328 4. The Director must also watch the condition of the metallic strip; he will not permit the bout to be started or to be continued if the metallic strip has holes capable of interfering with the registration of touches. (The organizers shall make provision for the rapid repair or replacement of metallic strips.)

II. VALIDITY OR PRIORITY OF THE TOUCH [RIGHT OF WAY]

§ 1. Principle

329 In *épée*, when both fencers are touched, the question of priority arises only in case it is possible to establish an appreciable difference in time between the touches; in the absence of this difference, there is a "double touch," i.e., a touch against each fencer.

* The fact that the Director has said "Fence," and even that a certain time has elapsed since that command, does not necessarily indicate an "effective resumption of the bout," if the fencers have remained in a passive attitude. It is necessary that the two fencers have actually entered into a phrase *d'armes* that might have affected the equipment in use.

§ 2. Judging

330 The scoring machines signal a double touch if the difference in time between the two touches is less than an interval measurable between 1/20 and 1/25 of a second.

In judging without a scoring machine, the Director alone decides if there was or was not a difference in time sufficient to confer priority, or if there was a double touch. If he has no opinion, he must declare a double touch.

331 If there is a double touch with both touches valid, both fencers are counted as touched.

If there is a double touch with one touch valid and one invalid (a touch made elsewhere than on the opponent—see 324—or a touch made after leaving the strip—see 43ff), the valid touch alone is scored.

If there is a double touch with one touch certain and the other doubtful (because of a defect in the scoring machine, or disagreement or uncertainty of the judges), the fencer who has made the certain touch has the choice of accepting the double touch or of having it annulled.

PART FOUR: SABRE

CHAPTER I—HISTORICAL NOTE

The sabre rules of the FIE reproduce the essentials of the rules that were adopted at the Olympic Games held in London in 1908 and in Stockholm in 1912. They likewise are in conformity with the principles of the Ostend rules and the Hungarian rules; they were adopted on 12 June 1914 by the FIE Commission on Sabre, meeting in Paris under the chairmanship of Dr. Bela Nagy, president of the Hungarian Fencing Federation, who was editor of the project.

The present rules merely complete and define those which were adopted in 1914, as subsequently amended by various later Congresses.

CHAPTER II—FIELD OF PLAY ["TERRAIN"]

(See 14ff).

401 Sabre competitions are fenced indoors on strips made of linoleum, cork, rubber, plastic, metal, metallic mesh, or material with a metallic base.

402 The width of the strip is from 1.8 to 2.0 meters, and its length is 24 meters. For practical reasons, the length of the strip is usually set at 14 meters, and each fencer will be given enough ground so that, being put on guard 2 meters from the center line, he has a total of 10 meters allowed him for retreating, before he crosses the rear limit with both feet (see 15, and the drawing on page 16).

403 Seven clearly visible lines are drawn on the strip, perpendicular to its length, thus:

—1 center line (which may be replaced by a central point or by a special mark at the edge of the strip);

—2 on-guard lines, located two meters on each side of the center line (these must be drawn across the full width of the strip);

—2 rear limit lines, which must be drawn across the full width of the strip, at a distance of seven meters from the center line; if sufficient ground is not available, the distance may be shorter; this distance may not, however, be less than 5 meters (see 15);

—2 warning lines, drawn two meters in front of the respective rear limits (these may be drawn only 30 cm inward from the edges of the strip).

When a fencer has gone beyond the rear limit of the strip with both feet [on a 14 meter strip] he is replaced on guard at the on-guard line, will be warned when he next reaches the warning line, and declared touched if he again crosses the rear limit with both feet (see 39/b).

CHAPTER III—EQUIPMENT FOR SABRE

(Weapons — Other Equipment — Clothing)

(See 16ff).

A. WEAPONS (See 22ff)

§1. General specifications for the sabre

a) Length

404 The total maximum length of the sabre is 105 centimeters.

b) Weight

405 The total weight of the sabre, ready for use, shall be less than 500 grams.

c) Blade

406 The blade is made of steel and its cross-section is approximately rectangular.

Its maximum length is 88 centimeters; the minimum width of the blade must be located at the button and must be at least 4 millimeters; its [minimum] thickness, also immediately below the button, must be at least 1.2 millimeters.

The end of the blade is folded back upon itself to form the button, which, viewed from the end, must have a square or rectangular cross-section, 4 millimeters minimum and 6 millimeters maximum in size; the maximum dimension must be located, at the farthest, at 3 millimeters from the end of the blade.

Blades that are too stiff or too whippy are prohibited, as are also sabres with unusual shapes. If the blade has a curve, it must be distinct and continuous and show a deflection that is less than 4 centimeters. Blades the ends of which are hooked, or which curve in the direction of the cutting edge, are prohibited.

All work performed to modify a blade, whether by grinding, filing, or other method, is prohibited, as is the sharpening of the part folded back to form the button (see 22).

d) Guard

(See 26).

407 The guard is solid, in one piece, and is externally smooth. Its shape is continuously convex, without rims or holes.

It must be able to pass through a rectangular gauge measuring 15 x 14 centimeters in cross-section, and having a height of 15 centimeters.

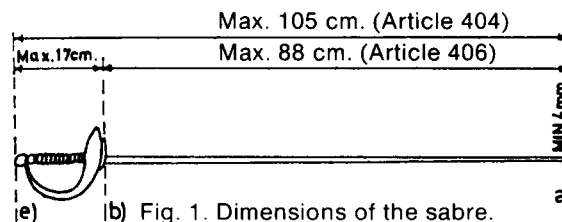

b) Fig. 1. Dimensions of the sabre.
Weight: less than 500 grams
(Article 405)

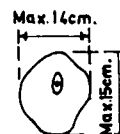
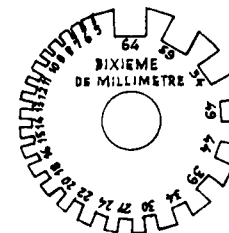

Fig. 2. The guard.
(Article 407)

Fig. 3. Curvature of the blade
(Article 406)



GAUGES



Gauge for checking the width and thickness of sabre blades.
(Tenths of millimeters)

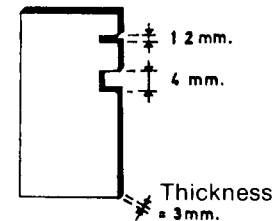

SABRE

Cutaway view of the end of the blade, along the length

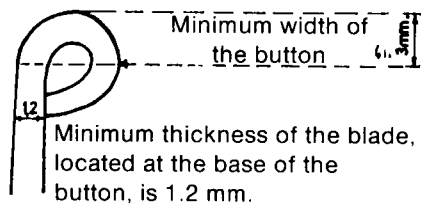

The largest part of the button must be located at most 3 mm from the end.

END OF THE SABRE BLADE
(Article 406)

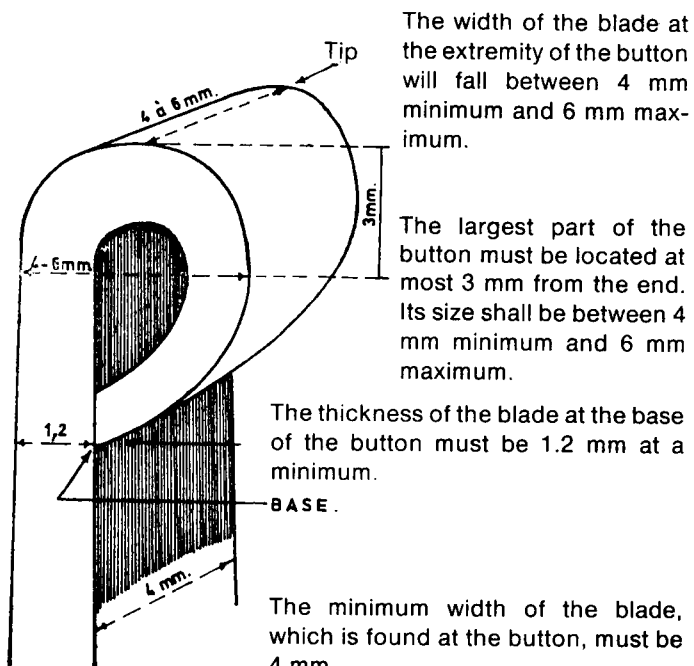

The width of the blade at the extremity of the button will fall between 4 mm minimum and 6 mm maximum.

The largest part of the button must be located at most 3 mm from the end. Its size shall be between 4 mm minimum and 6 mm maximum.

The thickness of the blade at the base of the button must be 1.2 mm at a minimum.

The minimum width of the blade, which is found at the button, must be 4 mm.

B. EQUIPMENT AND CLOTHING

- 408**
1. In sabre, the masks must be well padded and furnished with bibs that are sufficiently large and strong (see 27).
 2. The cuff or portion of the glove overlapping the sleeve may not be made of polished or hardened leather, or of any other material that could cause the blade to glance off.
 3. The elbow protector may be made of hard leather.
 4. The jacket must cover the valid surface of the trunk, with its lower part overlapping the trousers by at least 10 centimeters when the fencer is in the on-guard position (see 19, 410).
 5. The jacket must be made with a lining doubling the sleeve down to the inside of the elbow of the sword arm and the flank in the area of the armpit.
- In addition, the wearing under the jacket of a protective undergarment is obligatory. It must be made of hemp cloth, nylon, etc., and must
- a) have at least two thicknesses of material;
 - b) include a sleeve down to the inside of the elbow [of the sword arm], without seam or opening in the area of the armpit;
 - c) offer the best guarantees of safety.
- It may be attached to the jacket without being entirely sewn to it (see 27).

CHAPTER IV—CONVENTIONS OF SABRE FENCING

A. MANNER OF MAKING TOUCHES

- 409**
- The sabre is a weapon for thrusting and for cutting with fore-edge and back-edge; touches must be made cleanly and plainly with the point, the fore-edge, or the back-edge to be counted as touches (see 29).
- a) Touches made with any part of the fore-edge are known as "cuts"; those made with the forward third of the back-edge of the blade are known as "back-edge cuts" [or "counter cuts"]. Any touch made with any other part of the weapon, except the point, will not be counted.
 - b) Thrusts in which the point glides over the valid surface and the fore-edge or back-edge grazes the opponent's body (thrusts that pass) do not count even as cuts.
 - c) Cuts through the steel, i.e., those which at the same time touch the valid surface and the opponent's sabre, are valid whenever the fore-edge or back-edge arrives clearly on the target.

B. VALID SURFACE [TARGET]

§ 1. Limitation on the valid surface

- 410**
- In sabre, only touches that land on a surface classified as valid [the target] are counted.
- The valid surface comprises every part of the body situated above the horizontal line passing through the tops of the folds formed by the thighs and the trunk of the fencer when in the "on-guard" position (see drawing).

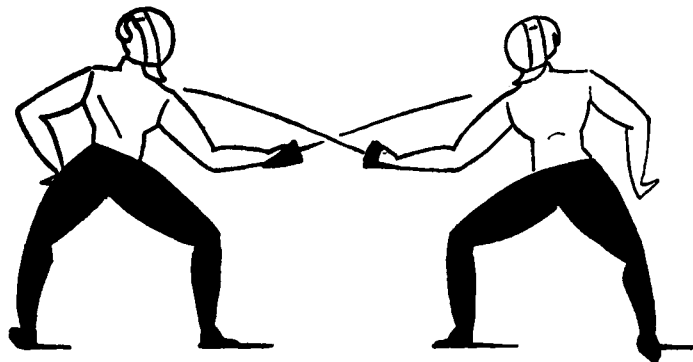

Valid Surface [target] in sabre

§ 2. Invalid surface

411 A touch which arrives on an invalid surface (whether directly or as the result of a parry) is not counted as a valid touch, but stops the phrase d'armes and thus annuls all subsequent touches.

C. CORPS A CORPS AND FLECHES

412 Whenever, in sabre, a fencer intentionally and systematically causes the corps à corps (even if without either brutality or violence), he must be penalized by a touch—after a warning given in the course of the same bout (see 34, 37, note to 318, and 641).

D. NUMBER OF TOUCHES—DURATION OF THE BOUT

413 In sabre, bouts are fenced for 5 touches, with a 6 minute time limit per bout; in direct elimination, two 5 touch bouts will be fenced with a deciding bout if necessary, or a bout for a specified number of touches (see 551f, 559).

414 When the time expires before the bout is decided:

a) if one of the competitors has received more touches than the other, there will be added to his score the number of touches necessary to reach the maximum, and the same number of touches will be added to his opponent's score;

b) if the score is tied, each competitor will be regarded as having received the maximum number of touches, less one, and they will fence for the last touch without limit of time. They will be replaced on guard in the places they occupied when the bout was interrupted (see 32).

E. JUDGING TOUCHES IN SABRE

415 All bouts in sabre are judged by a jury (see 61ff).

I. MATERIALITY OF THE TOUCH

(See Articles 68ff in Part ONE.)

II. VALIDITY OR PRIORITY OF THE TOUCH [RIGHT OF WAY]

§ 1. Preliminary note

416 When the Director, with the aid of his judges, has reached a decision on the materiality of the touch, it is then his responsibility alone to decide on the validity or priority of the touch, by applying the following principles which are the conventions proper to the sabre.

§ 2. Observance of the phrase d'armes

417 a) Every correctly executed attack (see 10) must be parried, or completely avoided, and the phrase d'armes must be followed.

b) The attack is the initial offensive action, executed by extending the arm and continuously threatening the valid surface with the point or cutting edge.

1. The attack by lunge is correctly executed:

—for a simple attack (see 11), when the arm is extended in the course of the lunge and the touch arrives, at the latest, when the forward foot touches the strip;

—for a composite attack (see 11), when the arm being extended in the correct presentation of the first feint (see 419), the touch arrives, at the latest, when the forward foot touches the strip, or immediately after.

2. The attack by flèche is correctly executed:

—for a simple attack (see 11), when the arm is extended in the course of the flèche and the touch arrives, at the latest, when the rear foot regains contact with the strip, or at the same time;

—for a composite attack (see 11), when the arm being extended in the correct presentation of the first feint (see 419), the touch arrives, at the latest, when the forward foot regains contact with the strip.

3. The attack by advance-lunge or advance-flèche is correctly executed:

—for a simple attack (see 11), when the arm has been extended before the end of the stop forward and the touch arrives, at the latest, on the final of the lunge or flèche (see 417/a and b);

—for a composite attack (see 11), when the arm being extended in the correct presentation of the first feint (see 419) during the advance, the touch arrives, at the latest, on the final of the lunge or flèche (see 417/a and b).

4. In any case, the attack by flèche must not end in a corps à corps (see 412).

It may be followed by a reprise of the attack, but only after a pause in the action (see 13/c).

5. If the flèche is followed by a run toward the opponent who has retreated to avoid being touched, this action may not be considered either as a redoublement (see 13/b) or as a remise. The initiation of an offensive action by the fencer who has sustained the flèche must, therefore, benefit from the priority [right of way] in the analysis of the phrase d'armes.

418 c) In judging the correctness of an attack, one must consider:

1. If the attack begins when the opponent is "in line," i.e., with "the arm extended and the point threatening a valid surface," the attacker must first deflect the opponent's weapon.*

* Directors must be alert that a mere grazing of the blades is not regarded as sufficient to deflect the opposing blade.

2. If, in searching for the opposing blade to deflect it, the blade is not found (derobement or trompement), the right of way passes to the opponent.

3. If the attack begins when the opponent is not in line, it may be made by a direct action or by disengagement, or by a cutover (coupé), or may also be preceded by efficient feints (see 419) that oblige the opponent to parry.

419 d) In composite attacks, feints must be correctly made, that is:
1. the feint by thrust with the point: with the arm extended and the point continuously threatening the valid target;

2. the feint by cut: with the arm extended, the blade and sword arm forming an obtuse angle of approximately 135°, the cutting edge threatening a valid surface.

e) In a composite attack, if the opponent finds the blade on one of the feints, he has the right to riposte.

f) On a composite attack, the opponent has the right to make a stop hit; but to be valid, the stop must precede the final of the attack by a period of fencing time, i.e., the stop must touch before the attacker has commenced the last movement of the conclusion of the attack.

420 g) Attack on the blade by beat

1. In an attack on the blade by beat, the attack is correctly executed and retains the right of way when the beat is made on the foible of the opposing blade, i.e., on the forward $\frac{2}{3}$ of that blade.

2. In an attack on the blade by beat, when the beat is made on the fort of the opposing blade, i.e., on the lower $\frac{1}{3}$ of that blade, the attack is improperly executed and such a beat gives the right of way to an immediate riposte by the opponent.

421 h) The parry gives the right to riposte: the simple riposte may be direct or indirect, but, to take the right of way over any subsequent actions of the attacker, the riposte must be executed immediately, without indecision or delay.

Against cuts, the parry is intended to bar access to the valid surface toward which the opponent's actions are directed; therefore:

1. the parry is correctly executed when, before the conclusion of the offensive action, it is opposed to the arrival of the opponent's blade, by closing the line in which that offensive action was intended to end.

2. when a parry is correctly executed, the offensive action of the opponent must be declared parried and must be judged as such by the jury, even if, because of its flexibility, the end of the blade reaches the target aimed at.*

§ 3. Judging

422 In applying these fundamental conventions of sabre, the Director must decide as follows:

1. When, in a phrase d'armes, the fencers are both touched simultaneously, there has been either a **simultaneous action** or a **double touch**.

The former is due to the simultaneous conception and execution of an attack by both fencers; in this case, the touches given are annulled for both fencers, even if one of them has touched an invalid surface.

* The Director, in the course of his analysis of the phrase, must demand precise responses from his judges: "Yes," "Yes, but on invalid surface [off-target]," "No," or "I abstain," and must systematically refuse such responses as "mal paré," "insufficient parry," "laid on," etc.

2. The double touch, on the other hand, is the result of a distinctly faulty action by one of the fencers.

As a result, if there is not a period of fencing time between the two touches:

(1) **The fencer attacked is alone counted as touched,**

a) if he makes a stop into a simple attack, made from close distance;

b) if, instead of parrying, he attempts to avoid being touched, and fails;

c) if, after a successful parry, he pauses for a moment—which gives his opponent the right to resume his attack (redoublement, remise, or reprise);

d) if, on a composite attack, he makes a stop without having the advantage of a period of fencing time;

e) if, being in line (arm extended and point threatening a valid surface), after a beat or a taking of the blade which deflects his weapon, he attacks or replaces his blade in line instead of parrying a direct attack made by the attacker.

(2) **The attacker alone is counted as touched,**

a) if he starts his attack when his opponent is in line (arm extended and point threatening a valid surface) without deflecting the opponent's blade;*

b) if he attempts to find the blade and fails (because of a derobement or trompement) and continues the attack;

c) if, in a composite attack, in the course of which the opponent finds the blade, he continues the attack while his opponent immediately ripostes;

d) if, in a composite attack, he hesitates for a moment during which time his opponent makes a stop or an attack, yet he himself continues his own attack;

e) if in a composite attack, he is hit by a stop made with the advantage of a period of fencing time before his conclusion;

f) if he touches by remise, redoublement, or reprise, after a parry by his opponent which is followed by an immediate simple riposte executed in one period of fencing time and without withdrawal of the arm.

(3) **The fencers are replaced on guard, every time that the Director cannot decide clearly which side is at fault in a double touch.**

One of the most difficult cases to decide occurs when there is a stop and there is doubt as to whether it had a sufficient time advantage over the conclusion of a composite attack. In general, in this case, the double touch is the result of simultaneous faults by the fencers, which fact justifies the replacement on guard. (The fault of the attacker lies in indecision, slowness, or inefficient feints; the fault of the fencer attacked lies in his delay or slowness in making the stop.)

PART FIVE: ORGANIZATION OF COMPETITIONS

CHAPTER I—COMPETITIONS

501 The official competitions of the FIE are organized according to special rules (see 579ff).

* Directors must be alert that a mere grazing of the blades is not regarded as sufficient to deflect the opposing blade.

502

Other international tournaments may include individual or team competitions for:

- women in foil
- men in all three weapons.

CHAPTER II—RESPONSIBILITY FOR SUPERVISION AND INSPECTION

§ 1. Organizing Committee

(See 616.)

503

The Organizing Committee is the group of persons bearing the responsibility for organizing a championship or tournament.

§ 2. Central Office of the FIE

(See 621.)

504

At the World Championships, at the World Under-20 Championships, and at the Olympic Games, the Central Office of the FIE controls the operations of the Directoire Technique as described in Article 590.

§ 3. Directoire Technique*

(See 617.)

505

a) The technical organization of competitions is entrusted to a Directoire Technique (this procedure is mandatory for the official FIE competitions), which is composed of seven members for the Olympic Games, six members for the World Championships, and five for the World Under-20 Championships. The Directoire Technique includes one member from the organizing country; the other members come from as many different countries (see 589).

b) For an official FIE competition, the Directoire Technique will be appointed by the Central Office of the FIE, by agreement with the national federation organizing the event.

c) For the Olympic Games, this agreement shall be reached with the Organizing Committee appointed by the Olympic Committee of the host nation to arrange the fencing events.

d) The members of the Directoire Technique may not combine their duties with any other activity in the tournament, such as member of the Jury of Appeal, team captain, official delegate of their national federation, competitor, etc. As an exception, they may be designated as Directors or members of a jury. They have among their duties the strict and complete organization of the competition and the obligation to enforce the rules, from which they may not permit any deviation except in a case in which it would be absolutely impossible to apply them.

e) In every other international competition, a Directoire Technique of

* [In the AFLA, the body exercising the authority and functions of the Directoire Technique is usually called the "Bout Committee."]

three members from different countries, one of whom will be from the country where the competition is being held, may be sufficient.

§ 4. Jury of Appeal

(See 618.)

a) Appointment

506 At each international competition in which representatives of two or more different nationalities participate, there must be established an international Jury of Appeal, which includes one representative from each participating country.

In the official FIE competitions, the members of the Jury of Appeal must be designated in writing by their national federations, no later than the eve of the competition.

Members may not participate in the deliberations when they are themselves involved in the appeal, either personally or by reason of an official position. They may not be replaced by substitutes if unable to participate, and no member of the Jury of Appeal may exercise a proxy to vote in the name of an absent colleague.

b) Presiding officer

507

The Jury of Appeal is presided over ex officio by the delegate of the Central Office of the FIE, who will vote only to break a tie. In the absence of a delegate of the Central Office, the Jury of Appeal itself will select its presiding officer from among its members. In this case, the presiding officer so named will always vote; should there be a tie, his vote is the deciding one.

c) Competence

508

The Jury of Appeal may not under any pretext decide to depart from the rules of the FIE, even with the consent of the parties concerned (see 505/d); it can hear only complaints and appeals that are submitted to it in accordance with the rules.

d) Meetings

509

The members of the Jury of Appeal who are present when a protest is lodged are convened immediately by the Directoire Technique or, in an appropriate case, by the Organizing Committee; however, if a decision is not required immediately, the Jury of Appeal may be assembled later. For this purpose, the members of the Jury of Appeal should inform the Organizing Committee of where they can be reached in an emergency, if they will not be present.

e) At the Olympic Games

510

At the Olympic Games, the decisions of the Jury of Appeal are final, except for any dispute of a non-technical nature, for which the court of last resort is the Executive Committee of the International Olympic Committee, which may intervene, either on its own initiative, or at the request of a national Olympic Committee, or of the FIE, or of the Organizing Committee (See Article 39 of the General Rules for the Olympic Games, 1971 edition) (see 619).

f) Guaranty

511

In submitting a complaint to the Jury of Appeal, the appellant must deposit a guaranty of one hundred French francs or its equivalent in other currency, which may be confiscated for the benefit of the FIE, in whole or in part, in case of a "frivolous appeal" (see 614).

§ 5. The Jury

512 All members of the jury are appointed in accordance with Articles 56ff and 610.

513 The *Directoire Technique* at any time and without having to justify their decision, may change the composition of a jury (and particularly for the bouts in a fence-off [*"barrage"*]) (see 610).

514 In an emergency, the Central Office of the FIE may appoint the juries for particular competitions.

515 For the finals of individual competitions comprising six fencers or more, there will be, so far as possible, two complete juries (or two Directors judging with a scoring machine). (This procedure is mandatory for the official FIE competitions) (see 58).

§ 6. Auxiliary personnel

516 The auxiliary personnel necessary for the efficient operation of a competition include:

a) The **Scorekeepers** (who keep the score sheets on which the results of each bout are entered, touch by touch, and who post upon the scoreboard the corresponding entries) (see 59).

b) The **Timekeeper** (who monitors the duration of each bout according to Articles 45ff and 59).

c) The **Scoring Machine Operator** (who is concerned with the machine) (see 60/a).

d) The **Experts** [**Technicians**] (who may be consulted by the Director or by the *Directoire Technique* on any question relating to the electrical scoring equipment) (see 60/b).

e) The **Repairmen** (who are present to remedy breakdowns occurring in the electrical equipment) (see 60/c).

§ 7. Inspection [*"Contrôle"*] of equipment

517 The inspection of the electrical equipment supplied by the organizers to ensure the flawless operation of an official FIE competition, as well as the inspection of the competitors' equipment, must be performed under the supervision of the Commission on Electrical Scoring and Equipment of the FIE.

To carry out this supervision, two members of the said Commission must be appointed and made responsible for this work. However, when the country organizing the competition can furnish a qualified person, acceptable to the Commission, only one member of the Commission will be appointed (see 17, 53, 60/b, 516/d and 708).

CHAPTER III—ENTRIES FOR COMPETITIONS

518 For international competitions, entries must be submitted to the organizers by the national federation of the participant (or by the federation that issued his international license, if he is not residing in his

native country).

All members of federations affiliated with the FIE are prohibited from participating in a competition organized by a person or club not affiliated with the national federation of their country, unless the competition has been specifically authorized by that federation.

CHAPTER IV—INSPECTION PRELIMINARY TO A COMPETITION

(See Articles 17ff).

CHAPTER V—SCHEDULE

519 The organizers will endeavor to conclude one type of competition before beginning another, in order to avoid undue fatigue for the fencers.

520 The schedule must be so planned that no fencer will be obliged to participate in actual competition for longer than twelve hours out of twenty-four. In any case, no pool or team match may begin after midnight, nor at a time when it is certain that it will be concluded long after midnight.

Whatever the formula for the competition, the finals must start at a time which, taking into account local customs, will permit the results to be sent to newspapers, etc. early enough to be published.

The organizers must provide sufficient time in the schedule for carrying out the inspection of the competitors' equipment, i.e., one day minimum for each weapon. If fencing in two weapons is scheduled for the opening day, the inspection must begin two days before the competition.

521 When a tournament includes several individual competitions in succession, fencers who have competed in the final of one event, if they have not had twenty-four hours rest, will be excused from [given a bye in] the first elimination round of the succeeding competition.

Fencers who have actually fenced for a team in the final of a team competition in one weapon, if they have not had twenty-four hours rest, will be excused from [given a bye in] the first elimination round of the individual competition in that same weapon, if the individual event follows the team event.

CHAPTER VI—INDIVIDUAL COMPETITIONS

522 Individual competitions may be organized:

- A. by pools.
- B. by pools, with the mixed formula of pools of 4, once 48, 24 or 12

fencers have been qualified by the elimination pools.

C. by direct elimination, integral formula.

D. by direct elimination, with the mixed formula of two rounds of elimination pools, then a direct elimination table with repêchage, in order to qualify six fencers for a final pool.

A. BY POOLS

§ 1. Number of fencers to a pool

523 a) for one touch (épée), the pools will in principle consist of a minimum of 10 competitors.

b) for several touches, they may consist of a smaller number, but no fewer than 4.

c) however, final rounds will consist of at least 6 fencers.

§ 2. Composition of pools

524 In the first round, the principle of seeding ["Tetes de serie"] must be observed. The Directoire Technique is the sole judge of which fencers it shall classify in the seedings, although it is understood that each national federation should indicate the ranked order of its fencers on the entry form, for the information of the Directoire Technique.

The principle of seeding must not be interpreted in the singular, thus it is possible to have in each pool fencers who are first, second and third seeded, etc.

Beginning with the second round, the pools must all have the same number of fencers, so as to arrive at:

either 4 quarter-final pools of 6 fencers, or 3 pools of 6 fencers.

In either case, 12 fencers must be qualified to form two semi-final pools of 6 fencers, each qualifying 3 to the final.

525 In the second round of elimination pools and in succeeding rounds, the distribution of fencers into each pool will be accomplished by following a table of classification established by taking into account only the indicators ["indices"] obtained by each fencer in the preceding round.

1. The first indicator, which is the chief means of classification, is obtained by dividing the number of each fencer's victories by the number of bouts he has fenced in the pool (formula V/B ["V/M"]); the highest indicator (the maximum is 1.0) being the highest classed.*

2. In case of a tie in the first indicator, there is established, to break such ties, a second indicator, obtained by dividing each fencer's number of touches scored by his number of touches received in the pool (formula TS/TR ["TD/TR"])*.

In case there is a tie in both indicators, the fencers who are tied will be placed by drawing lots. In case a fencer's classification would put him in a pool where another fencer of his nationality is already placed, he shall be relocated one or more places toward the bottom of the classification.

In case a fencer would be placed by his classification in a pool in which there are already two fencers who were with him in the same pool in the preceding round, he shall be relocated as far as possible.

* See the two tables in which the indicators are calculated under the rules for mixed formulas: pools and direct elimination.

Example of the composition of pools:

Starting with the second round, pools must be made up according to the classifications obtained by the fencers by taking count of the indicators of the preceding round, in the manner of the following example:

| Pools: | A | B | C | D | E |
|----------------------|----|----|----|----|----|
| Fencers classed No.: | 1 | 2 | 3 | 4 | 5 |
| | 10 | 9 | 8 | 7 | 6 |
| | 11 | 12 | 13 | 14 | 15 |
| | 20 | 19 | 18 | 17 | 16 |
| | 21 | 22 | 23 | 24 | 25 |
| | 30 | 29 | 28 | 27 | 26 |

§ 3. Order of bouts

526 In each pool, the order of bouts will be as follows:

| Pool of 4 | Pool of 5 | Pool of 6 | Pool of 7 | Pool of 8 | Pool of 9 | Pool of 10 | | | |
|-----------|-----------|-----------|-----------|-----------|-----------|------------|-----|------|------|
| 1-4 | 1-2 | 1-4 | 1-4 | 2-3 | 7-5 | 1-9 | 3-1 | 1-4 | 2-7 |
| 2-3 | 3-4 | 2-5 | 2-5 | 1-5 | 3-6 | 2-8 | 2-4 | 6-9 | 3-8 |
| 1-3 | 5-1 | 3-6 | 3-6 | 7-4 | 2-8 | 3-7 | 5-9 | 2-5 | 4-9 |
| 2-4 | 2-3 | 5-1 | 7-1 | 6-8 | 5-4 | 4-6 | 8-6 | 7-10 | 6-5 |
| 3-4 | 5-4 | 4-2 | 5-4 | 1-2 | 6-1 | 1-5 | 7-1 | 3-1 | 10-2 |
| 1-2 | 1-3 | 3-1 | 2-3 | 3-4 | 3-7 | 2-9 | 4-3 | 8-6 | 8-1 |
| | 2-5 | 6-2 | 6-7 | 5-6 | 4-8 | 8-3 | 5-2 | 4-5 | 7-4 |
| | 4-1 | 5-3 | 5-1 | 8-7 | 2-6 | 7-4 | 6-9 | 9-10 | 9-3 |
| | 3-5 | 6-4 | 4-3 | 4-1 | 3-5 | 6-5 | 8-7 | 2-3 | 2-6 |
| | 4-2 | 1-2 | 6-2 | 5-2 | 1-7 | 1-2 | 4-1 | 7-8 | 5-8 |
| | | 3-4 | 5-7 | 8-3 | 4-6 | 9-3 | 5-3 | 5-1 | 4-10 |
| | | 5-6 | 3-1 | 6-7 | 8-5 | 8-4 | 6-2 | 10-6 | 1-9 |
| | | 2-3 | 4-6 | 4-2 | 7-2 | 7-5 | 9-7 | 4-2 | 3-7 |
| | | 1-6 | 7-2 | 8-1 | 1-3 | 6-1 | 1-8 | 9-7 | 8-2 |
| | | 4-5 | 3-5 | | | 3-2 | 4-5 | 5-3 | 6-4 |
| | | | 1-6 | | | 9-4 | 3-6 | 10-8 | 9-5 |
| | | | 2-4 | | | 5-8 | 2-7 | 1-2 | 10-3 |
| | | | 7-3 | | | 7-6 | 9-8 | 6-7 | 7-1 |
| | | | 6-5 | | | | | 3-4 | 4-8 |
| | | | 1-2 | | | | | 8-9 | 2-9 |
| | | | 4-7 | | | | | 5-10 | 3-6 |
| | | | | | | | | 1-6 | 5-7 |
| | | | | | | | | | 1-10 |

526add When a pool contains several fencers from the same country:

a) if they do not comprise the majority, they must fence among themselves before meeting the competitors of another nationality;

b) if they do comprise the majority, the Directoire Technique may arrange a special bout order, endeavoring to depart as little as possible from the principle of a above, with the aim of avoiding undue fatigue or excessive interruptions for the fencers in the majority;

c) when "stateless" fencers take part in a pool, they must first fence against the competitors of their original nationality, after the latter have fenced among themselves, and then against the fencers of the country through which they hold their international license;

d) Example of the placement of fencers of the same nationality in a pool of six:

1. When the pool includes among the 6 qualified fencers
 —either 2 fencers of the same affiliation A,
 —or 2 fencers of affiliation A and 2 of affiliation B,
 —or 2 fencers of affiliation A, 2 of affiliation B, and 2 of affiliation C;
 the fencers are placed on the score sheet of the pool so that the pairs will fence each other in their first bout, and the order of bouts in the pool is that set forth in Article 526.

2. When the pool includes among the 6 qualified fencers
 —either 3 fencers of the same affiliation A,
 —or 3 fencers of affiliation A and 2 of affiliation B,
 —or 3 fencers of affiliation A and 3 of affiliation B; the fencers will be placed on the score sheet for the pool in the following fashion:
 —the fencers of affiliation A on 1, 2, and 3
 —the fencers of affiliation B on 4 and 5, or 4, 5 and 6, but the order of bouts set forth in Article 526 must be modified and becomes the following: 1-2; 4-5; 2-3; 5-6; 3-1; 6-4; 2-5; 1-4; 5-3; 1-6; 4-2; 3-6; 5-1; 3-4; 6-2.

3. When the pool includes, among the 6 qualified fencers, 4 fencers of the same affiliation A and 2 others of different affiliations, the 4 fencers of the same affiliation are placed on the score sheet for the pool in 1, 2, 3 and 4, and the order of bouts becomes the following: 1-4; 2-3; 5-6; 1-3; 2-4; 3-4; 1-2; 3-6; 2-5; 1-6; 3-5; 4-6; 1-5; 2-6; 4-5.

e) Example of the placement of fencers of the same nationality in a pool of 7:

1. When the pool includes among the 7 qualified fencers
 —either 2 fencers of the same affiliation A,
 —or 2 fencers of affiliation A and 2 of affiliation B,
 —or 2 fencers of affiliation A, 2 of affiliation B, and 2 of affiliation C;
 the fencers of the same affiliation are placed on the score sheet in such fashion that the pair(s) fence their first bout between themselves, following the order of bouts set forth in Article 526 for a pool of 7.

2. When the pool includes among the 7 fencers
 —either 3 fencers of the same affiliation A,
 —or 3 fencers of affiliation A and 2 of affiliation B,
 —or 3 fencers of affiliation A, 2 of affiliation B and 2 of affiliation C; the 3 fencers of affiliation A must be placed on the score sheet 1, 2, 3; the 2 fencers of affiliation B on 4 and 5, and the 2 fencers of affiliation C on 6 and 7. The bout order set forth in Article 526 for a pool of 7 will no longer apply, and must be replaced by the following: 1-2; 4-5; 6-7; 3-1; 4-6; 2-3; 5-1; 6-2; 3-4; 7-5; 1-6; 4-2; 7-5; 5-6; 1-4; 2-7; 5-3; 7-4; 2-5; 7-1; 3-6.

527 In case a bout is interrupted by an accident, and the interruption is likely to be prolonged, the Director may (with the consent of the *Directoire Technique*, or, when applicable, of the *Organizing Committee*) change the order of bouts in such a way as to permit the competition to continue.

§ 4. Classification [standing] in the pools (elimination rounds)

528 In each pool, the number of victories obtained by each fencer establishes the classification. In case of a tie in victories between two or more fencers, the indicator TS/TR (the quotient of the sum of the touches scored divided by the sum of the touches received by the fencer in the pool) determines the classification.

In case of an absolute equality of victories and of TS/TR indicators

between two or more fencers, these will fence-off ["fence a barrage"] following the rules for the pool, if a fence-off is necessary to determine their qualification; otherwise they will be classed as tied ["ex-aequo"].

In case of a tie in victories in a fence-off involving more than two fencers, the classification will be obtained from the sum of the TS/TR indicators of the pool and of the fence-off.

There will be only one fence-off. However, in case of a new absolute equality of victories and TS/TR indicators in this fence-off, the fencers must fence-off again [supplementary barrage].

In *épée*, in a fence-off involving only two competitors, they will fence one 5-touch bout. There will be no double defeat on time; the fencers will fence for one touch to a conclusion. On the other hand, in a fence-off involving more than two fencers, the rules for the pool and the rules set forth above must be followed.

§ 5. Promotion to the next round (qualification)

529 The classification [standing] of the fencers in each pool determines their promotion to the next round, according to the number of fencers to be qualified per pool.

a) In bouts for one touch (*épée*), 50% of the participants in the pool will be promoted to the next round.

b) In bouts for several touches, in all three weapons, 3 or 4 fencers per pool will advance to the next round, as appropriate (at least 50% of the participants in the pool); in pools of 4 fencers, at least 2 shall qualify.

§ 6. Fence-off ["Barrage"]

530 The classification of the competitors in a fence-off will result from the new bouts, which will be fenced according to the rules applicable to the original pool.

In individual competitions, fence-offs must be held immediately after the original pool (see 513).

When 3 participants fence-off, the order of the bouts is as follows:

For the first bout, the selection is by lot, unless there are two fencers of the same nationality, etc. (see 526 add.).

Thereafter it is necessary to distinguish:

a) If the fence-off is for the first place in the final, or for qualification and two of the three fencers can qualify, the order will be as follows:

1st bout: fencer A against B;

2nd bout: fencer C against the loser of the 1st bout;

3rd bout: fencer C against the winner of the 1st bout. (However, if the fence-off is for qualification and C has won his first bout, this third bout is not needed).

b) If the fence-off is for qualification and only one fencer can advance, the order is the following:

1st bout: fencer A against B;

2nd bout: fencer C against the winner of the 1st bout;

3rd bout: not needed if C is defeated; otherwise C against the loser of the 1st bout.

§ 7. Final pool—classification

531 In case of a tie in number of bouts won in the final pool, the classification will be made by fence-off, but only for the first place.

This fence-off will follow the rules for the pool and will determine the final standing of the fencers who participate in it.

There will be only one fence-off. In case of a tie in number of victories in a fence-off involving more than two competitors, the final standings will be determined by the sum of the TS/TR indicators of the final pool and of the fence-off. If there is a new and absolute equality of bouts won and TS/TR indicators, the fencers will have to meet in a supplementary fence-off.

For places other than first, in case of a tie in victories, the classification will be determined according to the TS/TR indicators of each of these fencers in the final pool. In case of equality in the indicators, the fencers will be classed as tied, except at the Olympic Games, where a fence-off will be required to separate fencers tied in victories and indicators, so as to secure a classification without ties for the second and third places.

In épée, if the fence-off for first place involves only two fencers, these will fence one 5-touch bout. There will be no double defeat on time; the fencers will fence for one touch to a conclusion. On the other hand, a fence-off involving more than two fencers will follow the rules for the pool and the preceding rules.

§ 8. A fencer not finishing a competition

a) Basic principles

532 1. No one may be put to a disadvantage by the fact that he has not been able to fence one or more bouts that he regularly would have fenced.

2. No one may profit by the fact that he has not met all the opponents that he would normally have fenced.

b) When only one competitor withdraws

533 When, for whatever reason, a competitor (individual or team) does not finish a competition that has begun, the Directoire Technique (without prejudice to possible disciplinary penalties that may be imposed) is required to apply the following rules:

PRELIMINARY STEPS

534 1. When a competitor (individual or team) in the course of a competition (pool) does not finish one of the bouts (or one of the team matches) scheduled and already commenced in the pool, at a time in this bout or team match when the opponent is ahead, this bout or team match will be considered as having been completed, and all the touches that remain to be fenced for will be credited to the opponent who has not abandoned the competition. In all other cases, the bout or team match is regarded as not having been fenced.

535 2. When the competitor who withdraws has won no victories before his withdrawal, he is considered as not having fenced.

EXAMPLES

1. Pool of teams: match between teams X and Z. Total of bouts 16. When the score is: X 9 victories (or even only 6 victories) and Z 2 victories, team Z abandons the competition: the official score of this match will be X 14 victories, Z 2 victories. If, however, the score had been 5-5 in

this match, or even 3-2, in favor of Z, which then withdrew, the whole match is annulled.

2. Pool of individuals, 5-touch bouts: The bout between A and B has begun; when the score is 3-2 in favor of B, A is obliged to withdraw; in this bout, B will be the victor by an official score of 5-2. If, however, the score had been 3-3, or 3-2 in favor of A, who then abandoned the competition, the bout would be annulled.

RULE ONE

536 When the event (pool) is completely finished (with the exception of the bouts of the competitor who did not finish), the Directoire Technique establishes two complete tables of classification [score sheets] by bouts won, with an exact determination of the places (by following the general rules for classification according to the formula under which the competition is being run).

First table.—A. Classification including only those competitors who have fenced all the bouts scheduled in the pool.

Second table.—B. Classification including only those competitors who have not fenced the competitor who withdrew.

RULE TWO

537 The relative order of the competitors on the same table is final as among themselves.

RULE THREE

538 1. For the final pool

For first place, there must always be a fence-off between the best placed fencer on Table B and the best placed fencer on Table A if the latter has the same number of victories as, or only one more than, the fencer from Table B.

Successively, to determine each final place (and with the proviso that the classification on each table remains final as among the fencers on that table) the fencer who is—or who remains—the best placed on Table B will fence-off against the competitor who is—or who remains—the best placed on Table A and whose total of victories is equal to his total or equal to his total plus one; however, there will be no fence-off when the number of touches scored and received is such that, if the event had been normally finished, the fencer from Table B could not have surpassed the classification of the fencer from Table A, even if he had won the unfenced bout 5-0, or could not have been surpassed by the aforesaid fencer, even if he had lost the unfenced bout 5-0.

EXAMPLE: Pool of 6 fencers (see table 1, page 74).

| Table A | | Indicators |
|---------|---------------|------------|
| 1st | G 4 victories | 1.500 |
| 2nd | V 3 victories | 1.150 |
| 3rd | X 1 victory | 0.739 |
| Table B | | |
| 1st | H 3 victories | 1.187 |
| 2nd | L 1 victory | 0.789 |

On Table B (the fencers who did not meet K, who abandoned the competition), H is the best placed with one victory fewer than G, the best placed on Table A (the fencers who did meet K). H, therefore, must fence-off against G for the first place.

- a) if H wins the fence-off, the result is: 1st H, 2nd G, 3rd V;
 b) if G wins the fence-off, then: 1st G; but for the second place there must be a fence-off between V and H (RULE THREE, see 538) who both have the same number of victories;
 if H wins this second fence-off, then: 1st G, 2nd H, 3rd V;
 if V wins it: 1st G, 2nd V, 3rd H.
 c) for the fourth and fifth places there must likewise be a fence-off (RULE THREE, see 538) between L and X, and:
 if L is the winner, he is 4th and X is 5th;
 if X is the winner, he is 4th and L is 5th.

However, fence-offs between the fencers on each of the Tables A and B, who have the same number of victories, will not be necessary when the TS/TR indicator of the fencer from Table B will always be superior to that of the fencer from Table A even if he had lost 5-0 the bout not fenced against the fencer who withdrew, or when the TS/TR indicator of the fencer from Table B will always be less than that of the fencer from Table A even if he had won 5-0 the bout not fenced against the fencer who withdrew.

d) as for the classification of K, who abandoned the competition, if his action was the result of circumstances beyond his control, RULE FOUR applies (see 539).

2. For a pool in an elimination round

With the proviso that the classification on each Table remains final as among the fencers on that Table, the procedure is like that for a final pool, applying, however, the complementary rules set forth below.

EXAMPLE:

| Table A | | Indicators |
|---------|-------------|------------|
| 1st G | 4 victories | 1.500 |
| 2nd V | 3 victories | 1.150 |
| 3rd X | 1 victory | 0.739 |
| Table B | | |
| 1st H | 3 victories | 1.187 |
| 2nd L | 1 victory | 0.789 |

1st case: 4 fencers are to qualify for the next round.

In this case, G, V and H are already qualified and a fence-off is required between L and X to decide the fourth qualifier.

If L wins he qualifies, but he has fenced one fewer bout (not having met K, who withdrew). To make equitable the classification of L in the classification by the indicators, as is mandatory among qualifiers for the arrangement of the pools in the next round, the fence-off bout against X will be included in the calculation of L's indicators (both V/B and TS/TR).

If X is the winner of the fence-off, he qualifies, but keeps his indicators from the pool, since he has fenced all his bouts.

Likewise, to make equitable the classification by indicators for H, there will be a fence-off bout between V and H who have both the same number of victories. Whatever the result of this bout:

—V retains his indicators from the pool, since he has fenced all his bouts;
 —as for H, who had fenced one fewer bout as the result of the withdrawal of K, the results of the fence-off bout will be included in the calculation of his V/B and TS/TR indicators, just as for L.

2nd case: 3 fencers are to qualify for the next round.

In this case, G, V and H are qualified, but there must be a fence-off bout between V and H, in order to make equitable the indicators. The results of this bout will be counted only for H; V retains his indicators from the pool.

RULE FOUR

539 A competitor (individual or team), obliged to abandon the competition as the result of circumstances beyond his control, duly recognized by the Director, has the right to the classification earned by his actual total of points; but if a fence-off should be necessary with one or another of his opponents, he loses the benefit of fencing-off. In other cases of abandoning a competition, he loses all right to any classification whatever, without prejudice to possible disciplinary penalties.

c. When more than one competitor does not finish the competition (see 532)

540 To apply the basic principles to this situation (see 532ff), the following supplementary rules are to be added to the rules preceding.

1. When more than one competitor fails to finish in a pool: as soon as the pool is completed the Directoire Technique will draw up the following tables of classification [score sheets] (the order of the competitors on the same table being final as among themselves):

Table A, including only the competitors who have fenced all the bouts scheduled in the pool;

Table B, including only the competitors who have fenced all the scheduled bouts, less one;

Table C, including only the competitors who have fenced all the scheduled bouts, less two;

And so forth as required.

2. Every fencer who has not fenced one or more bouts must fence-off against the best placed fencers on the other tables with whom he might possibly have had the same number—or a greater number—of victories (except in cases where, as set forth in RULE THREE above, the number of touches scored and received (TS/TR indicator) makes this fence-off unnecessary).

3. For the first place in a final pool, each Table having its own final classification, it is first ascertained which of the best placed fencers in each Table has the greatest number of victories.

If it is the fencer from Table A, he must fence-off against the best placed fencer from Table B having the same number of victories, or one fewer than, himself; and against the best placed fencer from Table C having the same number of victories as, or one or two fewer than, himself; and against the best placed fencer from Table D having the same number of victories as, or one, two or three fewer than, himself, and so forth.

If it is a fencer from Table B, he must fence-off against the best placed fencer from Table C having the same number of victories as, or one fewer

FIRST EXAMPLE: TABLE 1Pool of 6 fencers; 5-touch bouts
(Article 538, Rule Three above)

| Fencers N° | Table A | | | | | | Table B | | | | | | | | | |
|------------|---------|---|----|----|----|----|----------|---|----|----|-------|---|---|----|----|-------|
| | 1 | 2 | 3 | 4 | 5 | 6 | V | D | TS | TR | TS/TR | V | D | TS | TR | TS/TR |
| G | | | V2 | V3 | D | V2 | 4 | 1 | 24 | 16 | 1.500 | | | | | |
| H | D | | | V4 | V4 | V3 | | | | | | 3 | 1 | 19 | 16 | 1.187 |
| K | D | | | | V4 | D | Withdraw | | | | | | | | | |
| L | D | D | | | D | V4 | | | | | | 1 | 3 | 15 | 19 | 0.789 |
| V | V4 | D | D | V3 | | V3 | 3 | 2 | 23 | 20 | 1.150 | | | | | |
| X | D | D | V3 | D | D | | 1 | 4 | 17 | 23 | 0.739 | | | | | |

SECOND EXAMPLE: TABLE 2

Pool of 9 fencers; 5-touch bouts

| Fencers | Table A | | | | | | | | | Table B | | | C |
|---------|---------|-----|-----|-----|-----|-----|-----|-----|-----|----------|-----------|----------|---------|
| | L | M | N | O | P | Q | R | S | T | A | B | | |
| L | | - | - | - | V.2 | D | - | - | V.2 | Withdraw | | | |
| M | - | | V.3 | V.O | - | V.3 | D | V.1 | D | | | | 4V. 7.5 |
| N | - | D | | V.4 | V.2 | D | D | V.1 | D | | | 3V. 7.13 | |
| O | - | D | D | | | V.3 | V.2 | V.2 | D | | | | 3V. 7.4 |
| P | D | - | D | - | | V.4 | D | - | - | Withdraw | | | |
| Q | V.3 | D | V.3 | D | D | | V.2 | V.3 | D | | 4V. 11.12 | | |
| R | - | V.1 | V.3 | D | V.3 | D | | D | D | | | 3V. 7.10 | |
| S | - | D | D | D | D | D | V.3 | | V.4 | | | | 2V. 7.7 |
| T | D | V.4 | V.4 | V.O | - | V.2 | V.3 | D | | | | 5V. 13.6 | |

than, himself; and against the best placed fencer from Table D having the same number of victories as, or one or two fewer than, himself, and so forth.

If it is a fencer from Table C, he must fence-off against the fencer from Table D having the same number of victories as, or one fewer than, himself; and against the fencer from Table B who has only one victory fewer than himself.

And so forth as required.

The winner of this fence-off will be classified first in the final; the classification of the other fencers who have participated in the fence-off will be final as among themselves on the basis of the fence-off, but other fencers may come between them in the classification.

4. For the other places in the final, every fencer who has not fenced one or more bouts of the final pool, will fence-off against the fencers from the other Tables with whom he might possibly have had the same number of victories (except when the number of touches scored and received by the various competitors involved is such that this fence-off would be unnecessary).

5. In the elimination pools, for determining qualification to the next round, first those fencers certain to qualify and those certain not to qualify are identified, then a fence-off is held among all those who have a chance, according to the number of their actual or possible victories, of qualifying to the next round.

B. BY POOLS WITH THE MIXED FORMULA OF POOLS OF 4

§ 1. Formula for the competition

541 The Directoire Technique will arrange, according to the total number of entries, for one or two rounds of elimination pools in order to arrive at

- either 48 fencers
- or 24 fencers.

In both cases, there will then be several rounds of pools of 4 fencers, each pool qualifying two fencers in order to arrive at a final pool of 6 fencers.

In the first elimination round, the pools may be composed of from 4 to 7 fencers, according to the number of entries, with the proviso that no pool shall have more than one competitor more than any other.

Starting with the second round, the pools must have the same number of fencers, either 6 for the elimination pools or 4 for the pools after the field has been reduced to 48 or 24.

Bouts will be fenced:

- for men, in 5 touches, 6 minute time limit.
- for women, in 4 touches, 5 minute time limit (see 45).

§ 2. Composition of the pools

542 For the first round, the principle of seeding [Têtes de serie] must be observed. The Directoire Technique is the sole judge of which fencers it shall classify in the seedings, although it is understood that each national federation should indicate the ranked order of its fencers on the entry form, for the information of the Directoire Technique.

For the second elimination round, the distribution of fencers into each pool will be accomplished by following a classification table obtained by

counting the V/B and TS/TR indicators from the first round (see 525, definition of the indicators).

For the third round, the distribution of the fencers in each pool will be accomplished by following a classification table obtained by counting the indicators from the second round only.

For the following rounds, the classification table of the fencers for arranging the pools will be obtained by indicators derived by adding the victories and bouts fenced and the touches scored and received from all preceding rounds, except the first.

In case of a tie in both indicators between two or more fencers, their placement in the classification will be made by lot.

In case a fencer would be located by his classification in a pool where there is already a fencer of his nationality, he shall be relocated one or more places toward the bottom of the classification.

In case a fencer would be located by his classification in a pool where there are already two fencers who were with him in the same pool in the preceding round, he shall be relocated as far as possible.

Example of the composition of pools.

543 Starting with the second round, following the classification of the fencers qualified and taking into account the number of pools needed to complete the round:

| Pools: | A | B | C | D | E | F |
|----------------------|----|----|----|----|----|----|
| Fencers classed No.: | 1 | 2 | 3 | 4 | 5 | 6 |
| | 12 | 11 | 10 | 9 | 8 | 7 |
| | 13 | 14 | 15 | 16 | 17 | 18 |
| | 24 | 23 | 22 | 21 | 20 | 19 |

§ 3. Classification [standing] in the pools

a. In elimination pools

544 In each pool the number of victories won by each fencer establishes the classification.

In case of a tie in victories between two or more fencers, the TS/TR indicator determines their classification in the pool.

In case of an absolute tie in victories and TS/TR indicators between two or more fencers, these will fence-off according to the rules for the pool, if the fence-off is necessary to determine their qualification; otherwise they will be classed as tied.

In case of a tie in victories in a fence-off involving more than two fencers, their classification will be obtained by adding the TS/TR indicators of both the pool and the fence-off.

There will be only one fence-off. However, in case of a new absolute tie in victories and TS/TR indicators, the fencers must fence-off again.

In épée, in a fence-off involving only two fencers, these will fence one bout for 5 touches. There will be no double defeat on time; the fencers will fence for one touch to a conclusion. On the other hand, in a fence-off involving more than two fencers, the rules for the pool and the preceding rules will be observed.

b) In the pools of 4

545 In each pool the number of victories won by each fencer establishes the classification.

In case of a tie in victories between two or more fencers, their classification will be determined by a fence-off.

In a fence-off involving more than two fencers, if there is a new tie in victories, those tied must be separated by using the TS/TR indicators obtained by adding the touches scored and received in both the pool and the fence-off.

There will be only one fence-off. However, in case of a new absolute tie in victories and in TS/TR indicators in the pool and the fence-off, the tied fencers will fence-off again.

In *épée*, in the pools of 4, there will be no double defeat on time. If, at the expiration of the regulation time the two fencers have each received the same number of touches, or none at all, they will be regarded as having each received the maximum, 5. They will then fence for one additional touch to a conclusion, without limit of time; double touches will be annulled. The result will be entered on the score sheet as V5 and D5, as appropriate (see 320).

§ 4. Promotion to the next round (qualification)

546 The classification [standing] of the fencers in each pool determines their promotion to the next round, according to the number of fencers to be qualified per pool.

This number will be 3 or 4 as appropriate, with a minimum of 50% of the fencers in the pool; in the pools of 4, at least two shall qualify.

In case of a tie in victories in the pools of 4, a fence-off will be required to determine the qualifier(s) (see 545).

§ 5. Order of bouts in the pools

547 In the elimination rounds and in the final pool of 6, the order of bouts is that set forth in Article 526 (however, see 526 add).

The pools of 4 will be fenced by series of two bouts taking place simultaneously on two strips.

To allow the fencers in one pool time to rest, the bouts of a second pool may be fenced alternately with those of the first pool on the same strips.

The order of bouts will be as follows:

1st series: 1-4 and 2-3, these bouts being fenced simultaneously on two strips.

2nd series: the winners against the losers, these bouts being fenced simultaneously on two strips.

3rd series: the two remaining bouts.

If at the end of the first two series of bouts, one only of the four fencers has 2 victories, his third bout must be fenced before the other bout in the third series.

In the pools of 4, except for the last round qualifying the fencers for the final, the third series of bouts must be fenced out, even if the qualifiers are already determined, in order to obtain the indicators.

§ 6. Final pool—classification

548 In case of a tie in victories in the final pool, the classification—but only for the first place—will be determined by a fence-off, which will follow the rules for the pool and will determine the classification of the fencers who take part in it.

There will be only one fence-off.

In case of a tie in victories in a fence-off involving more than two fencers, the final classification will be obtained by using the sum of the TS/TR

indicators of the final pool and of the fence-off.

If there should be a new absolute tie in victories and in the sum of the TS/TR indicators, the fencers who are tied will fence-off again.

For the places other than first, when there are ties, the classification will be established according to the TS/TR indicators of each of the fencers in the pool. In case of a tie in these indicators, the fencers will be classed as tied, except at the Olympic Games, where in case of a tie in victories and indicators, there will be a fence-off to produce a classification without ties for the second and third places.

In *épée*, if a fence-off for the first place involves only two fencers, these will fence one bout for 5 touches. There will be no double defeat on time; the fencers will fence for one touch to a conclusion. On the other hand, in a fence-off involving more than two fencers, the rules for the pool and the preceding rules will be observed.

C. BY DIRECT ELIMINATION, INTEGRAL FORMULA

§ 1. Application of rules

549 The general provisions of the rules will be applicable without exception, insofar as they are not contrary to those herein specified in part C [for direct elimination].

§ 2. Organization of the competition

550 The Directoire Technique will organize a first elimination round, using the principles of seeding and of separating fellow nationals, and exempting from this first round [giving byes to] the number of top seeded fencers necessary to retain, after this first round, a number of fencers that will be a power of 2 (e.g., 4, 8, 16, 32, 64, 128, etc. fencers).

The formula to obtain the number of fencers to be given byes (E) is:

$$E = 2N - P$$

where P is the number of fencers entered and N the number of fencers to be retained, i.e., 4, 8, 16, 32 or 64, etc.

The direct elimination table is then established by following the principle of seeding, placing the fencers in their order of merit in positions 1, 2, 3, 4, and so forth, according to the sample tables (for 8, 16, 32, 64) fencers set out below (pages 83 and 84).

§ 3. Formula for the individual matches and number of touches

551 In all three weapons, each individual match by direct elimination will be fenced either for a fixed number of touches, or by two five-touch bouts (4 touches for women), with a deciding bout if necessary.

§ 4. Duration of individual matches

552 Six minutes per bout; for women, five minutes per bout. The bouts will be separated by a mandatory rest period of two minutes and the fencers will change ends on the strip.

If, in any one of the three bouts, the fencers are tied at the expiration of the regulation time, there will be an extension of the bout without time limit until a result is obtained (see 559).

§ 5. Withdrawal of a fencer

553 When, for whatever reason, a fencer is unable to continue, or unable to finish an individual match by direct elimination, his opponent is declared the winner of the match.

§ 6. Order of the individual matches

554 The individual matches are always called strictly in the order of the table, starting at the top and finishing at the bottom. In the interest of saving time, the organizers may have several matches fenced simultaneously on several strips, but the fencers must always be called in the same order.

A rest period of ten minutes must always be allowed between two matches by the same fencer.

§ 7. Classification [Final Standing]

555 The general classification is obtained in the following manner:
1st place: the winner of the final

2nd place: the loser of the final

For the rest, when it is not necessary to be more precise, the two losers of the semi-finals are tied for third; the four losers of the quarter-finals are tied for fifth; the eight losers of the eighth-finals are tied for ninth, etc.

If it is necessary to rank the fencers precisely, there will be a fence-off between the losers of the semi-final to determine the third and fourth places; a direct elimination fence-off among the quarter-final losers to determine the 5th, 6th, 7th and 8th places, etc.

D. BY DIRECT ELIMINATION, WITH THE MIXED FORMULA OF TWO ROUNDS OF ELIMINATION POOLS AND A DIRECT ELIMINATION TABLE WITH REPECHAGE, QUALIFYING 6 FENCERS FOR A FINAL POOL

§ 1. Elimination rounds

556 a) A first round will be fenced by pools, each qualifying 50% of the competitors (a minimum of four fencers).

The composition of the pools in this first round will be arranged on the responsibility of the Directoire Technique, possibly by taking into account information furnished by the team captains.

The pools will be fenced through the last bout, even if the results for qualification to the next round have been decided earlier.

b) A second round of pools will be fenced, each qualifying 50% of the competitors (a minimum of four fencers). In the arrangement of these pools, the Directoire Technique will use the results of the first round.

The pools will be fenced through the last bout, even if the results for qualification to the direct elimination table have been decided earlier.

§ 2. Classification in the pools and qualification

557 These first two elimination rounds will be without fence-offs. Promotion to the next round out of the two rounds of elimination pools will be determined, in case of a tie in victories, by counting the touches received and if necessary the touches scored. There will be a fence-

off only in case of an absolute tie in victories, touches received, and touches scored, and then only between the fencers having this absolute tie.

§ 3. Composition of the direct elimination table

558 The results of the fencers qualified out of the first round will be entered on a summary sheet showing the number of bouts fenced, the victories won, the touches received and the touches scored.

The results of the fencers qualified out of the second round will be entered on the summary sheet, following, and in the same manner as, the results of the first round.

The Directoire Technique will then proceed to make up the direct elimination table on which the qualifiers will be placed.

This table is that specified in the rules (see 563—table greater than or equal to the number of qualifiers).

A classification of the qualified fencers will be made as follows:

a) The results of the first and second rounds entered on the summary sheet will be added;

b) the first indicator which serves for the first classification will be obtained by dividing the number of victories by the number of bouts fenced (formula V/B);

c) the highest indicator (the maximum is 1.0) is the highest ranked;

d) in case of ties, to separate tied fencers, there will be a second indicator calculated by dividing the number of touches scored by the number of touches received (formula TS/TR).

In case of a tie in both indicators, the placement of the fencers so tied will be made by lot.

e) For the distribution of the places on the table, the classification described above will be used.

The highest placed fencer will be given number 1; the next, number 2, and so on for all the qualified fencers.

f) The only exception is admitted in the case of fencers of the same nationality. The latter, in principle, may not appear in the same quarter of the final table, unless there are five of them qualified.

Each time that the application of the procedure set forth above will place two or more fencers of the same nationality in the same quarter of the final table, that fencer having the lesser classification will be assigned to the next following number on the table that will change the quarter as necessary.

This rule is not applicable to the fifth fencer of the same nationality, in case five fencers of that nationality have qualified for the final table.

In addition, this exception will not be made for the last fencers qualified for the final table if the remaining places available do not permit the application of the paragraph above.

§ 4. Formula for the individual matches

559 All the individual matches on the direct elimination table will be fenced in two bouts of 5 touches (women's foil, 4 touches) with a maximum time of six minutes (women's foil, five minutes) per bout, and a deciding bout if necessary, with the understanding that there must be a result in each bout (see 552).

The bouts will be separated by a rest period of two minutes and the fencers will change ends of the strip after each bout (see 31, however).

§ 5. Repêchage—principles*

560 The principles governing repêchage are the following:
 —a fencer may not be eliminated until he has been defeated twice, once in the direct elimination table, and once in the repêchage table.*
 —all the matches in the repêchage table will always be fenced according to the results of the direct elimination table—i.e., Table A—as established by following the classification according to indicators, taking nationality into account.

§ 6. Order of the individual matches—Qualification

561 All the individual matches will take place in the order of the table of direct elimination and of repêchage, starting at the top and ending at the bottom.*

a) Direct elimination table (Tables A, B, C)
 The fencers in the different rounds of this table will meet in the order of the table to qualify 4 fencers for the final pool of 6.

b) Repêchage table (Tables D, E, F, G, and H).
 Table D is formed by the 16 fencers defeated in Table A, who will meet among themselves.

Table E is formed by the 8 fencers who won in Table D, who will meet the 8 losers from Table B.

Table F is formed by the 8 winners from Table E, who will meet among themselves.

Table G is formed by the 4 winners from Table F, who will meet the 4 losers of Table C.

Table H is formed by the 4 winners of Table G, who will meet among themselves to qualify 2 fencers to join the 4 fencers qualified from Table C to compose the final pool of 6.

§ 7. Final pool—Classification

562 The rules for the final pool of six fencers are as follows: the six qualifiers will fence a final pool of bouts in five touches (four for women), with a maximum time of six minutes (five for women);

The general rules for a pool will apply, with the possibility of a double defeat in épée and of a fence-off in case of a tie in victories for the first place.

In such a fence off,

a) if there are only two fencers, and if both fencers arrive at five touches, the bout will continue until one fencer has scored one touch over his opponent.

b) if there are more than two fencers, the classification will be made by counting—from only the fence-off—first the victories, and then, if necessary, the touches received, and finally the touches scored.

In case of a new tie in victories and in touches, a bout or as may be necessary a supplementary pool will be fenced between or among only those fencers remaining tied for first place.

In this new fence-off, there will be no double defeats, and each bout will be fenced to a conclusion, and, in case of a tie in victories in this last fence-off, account will be taken in order to determine first place, first of the touches received in the two fence-offs, and then of the touches scored in both fence-offs.

* See below for the chart of the direct elimination table with repêchage, pages 85-86.

563 § 8. Direct Elimination Tables for:

8 fencers

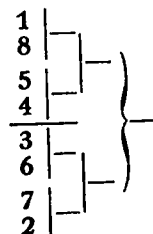

16 fencers

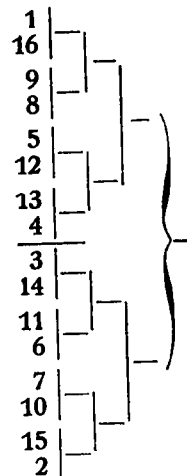

32 fencers

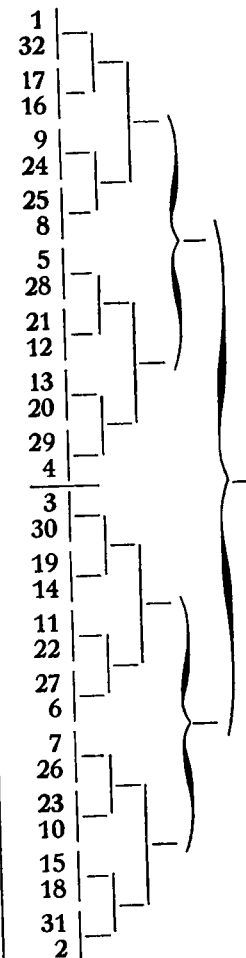

Note: On the tables the 1, 2, 3, etc. indicate the places to be assigned to the top seeded fencers, in order of merit.

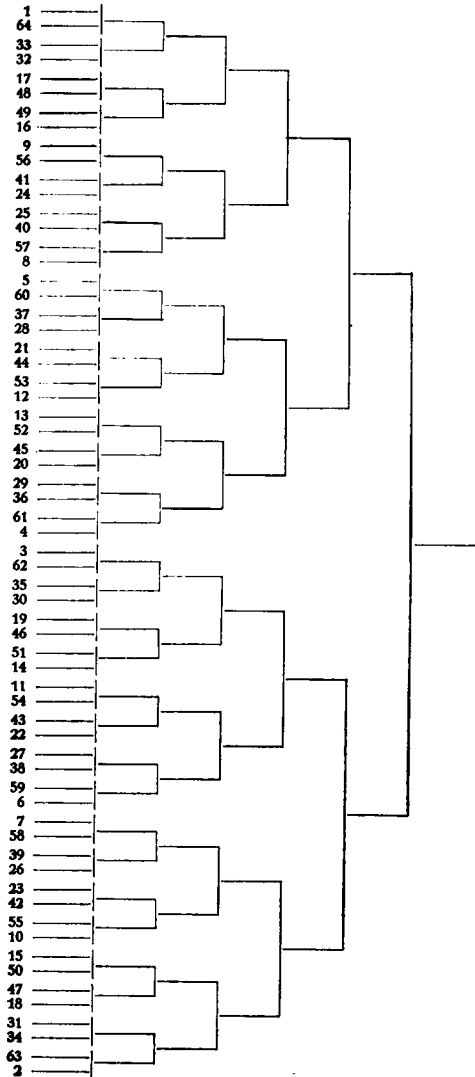
DIRECT ELIMINATION TABLE: 64 Fencers**TABLES FOR DIRECT ELIMINATION AND REPECHAGE**

[See next pages]

Table A: 32 fencers

Table B: 16 winners from Table A; 8 advance

Table C: 8 winners from Table B; 4 will qualify for the final pool

Table D: 16 losers from Table A; 8 will continue

Table E: 8 winners from Table D against the 8 losers from Table B;
8 will continue

Table F: 8 winners from Table E; 4 will continue

Table G: 4 winners from Table F against the 4 losers from Table C;
4 will continueTable H: 4 winners from Table G; 2 survive and qualify for the
final pool of 6.Abbreviations: el. — eliminated by two defeats.
qual. — qualified for the final pool.

FENCING RULES FOR COMPETITION
TS/TR TABLE OF INDICATORS

| | | TOUCHES RECEIVED | | | | | | | | | |
|---------|-------|------------------|-------|-------|-------|-------|-------|-------|-------|-------|-------|
| | | 2 | 3 | 4 | 5 | 6 | 7 | 8 | 9 | 10 | 11 |
| TOUCHES | 2 | 1 | 0,667 | 0,500 | 0,400 | 0,333 | 0,286 | 0,250 | 0,222 | 0,200 | 0,182 |
| | 3 | 1,500 | 1 | 0,750 | 0,600 | 0,500 | 0,429 | 0,375 | 0,333 | 0,300 | 0,273 |
| | 4 | 2,— | 1,333 | 1 | 0,800 | 0,667 | 0,571 | 0,500 | 0,444 | 0,400 | 0,364 |
| | 5 | 2,500 | 1,667 | 1,250 | 1 | 0,833 | 0,714 | 0,625 | 0,556 | 0,500 | 0,455 |
| | 6 | 3,— | 2,— | 1,500 | 1,200 | 1 | 0,857 | 0,750 | 0,667 | 0,600 | 0,545 |
| | 7 | 3,500 | 2,333 | 1,750 | 1,400 | 1,167 | 1 | 0,875 | 0,778 | 0,700 | 0,636 |
| | 8 | 4,— | 2,667 | 2,— | 1,600 | 1,333 | 1,143 | 1 | 0,889 | 0,800 | 0,727 |
| | 9 | 4,500 | 3,— | 2,250 | 1,800 | 1,500 | 1,286 | 1,125 | 1 | 0,900 | 0,818 |
| | 10 | 5,— | 3,333 | 2,500 | 2,— | 1,667 | 1,429 | 1,250 | 1,111 | 1 | 0,909 |
| | 11 | 5,500 | 3,667 | 2,750 | 2,200 | 1,833 | 1,571 | 1,375 | 1,222 | 1,100 | 1 |
| | 12 | 6,— | 4,— | 3,— | 2,400 | 2,— | 1,714 | 1,500 | 1,333 | 1,200 | 1,091 |
| 13 | 6,500 | 4,333 | 3,250 | 2,600 | 2,167 | 1,857 | 1,625 | 1,444 | 1,300 | 1,182 | |
| 14 | 7,— | 4,667 | 3,500 | 2,800 | 2,333 | 2,— | 1,750 | 1,556 | 1,400 | 1,273 | |
| 15 | 7,500 | 5,— | 3,750 | 3,— | 2,500 | 2,143 | 1,875 | 1,667 | 1,500 | 1,364 | |
| 16 | 8,— | 5,333 | 4,— | 3,200 | 2,667 | 2,286 | 2,— | 1,778 | 1,600 | 1,455 | |
| 17 | 8,500 | 5,667 | 4,250 | 3,400 | 2,833 | 2,429 | 2,125 | 1,889 | 1,700 | 1,545 | |
| 18 | 9,— | 6,— | 4,500 | 3,600 | 3,— | 2,571 | 2,250 | 2,— | 1,800 | 1,636 | |
| 19 | 9,500 | 6,333 | 4,750 | 3,800 | 3,167 | 2,714 | 2,375 | 2,111 | 1,900 | 1,727 | |
| 20 | 10,00 | 6,667 | 5,— | 4,— | 3,333 | 2,857 | 2,500 | 2,222 | 2,— | 1,818 | |
| 21 | 10,50 | 7,— | 5,250 | 4,200 | 3,500 | 3,— | 2,625 | 2,333 | 2,100 | 1,909 | |
| 22 | 11,00 | 7,333 | 5,500 | 4,400 | 3,667 | 3,143 | 2,750 | 2,444 | 2,200 | 2,— | |
| 23 | 11,50 | 7,667 | 5,750 | 4,600 | 3,833 | 3,286 | 2,875 | 2,556 | 2,300 | 2,091 | |
| 24 | 12,00 | 8,— | 6,— | 4,800 | 4,— | 3,429 | 3,— | 2,667 | 2,400 | 2,182 | |
| 25 | 12,50 | 8,333 | 6,250 | 5,— | 4,167 | 3,571 | 3,125 | 2,778 | 2,500 | 2,273 | |
| 26 | 13,00 | 8,667 | 6,500 | 5,200 | 4,333 | 3,714 | 3,250 | 2,889 | 2,600 | 2,364 | |
| 27 | 13,50 | 9,— | 6,750 | 5,400 | 4,500 | 3,857 | 3,375 | 3,— | 2,700 | 2,455 | |
| 28 | 14,00 | 9,333 | 7,— | 5,600 | 4,667 | 4,— | 3,500 | 3,111 | 2,800 | 2,545 | |
| 29 | 14,50 | 9,667 | 7,250 | 5,800 | 4,833 | 4,143 | 3,625 | 3,222 | 2,900 | 2,636 | |
| 30 | 15,00 | 10,00 | 7,500 | 6,— | 5,— | 4,286 | 3,750 | 3,333 | 3,— | 2,727 | |
| 31 | 15,50 | 10,33 | 7,750 | 6,200 | 5,167 | 4,429 | 3,875 | 3,444 | 3,100 | 2,818 | |
| 32 | 16,00 | 10,67 | 8,— | 6,400 | 5,333 | 4,571 | 4,— | 3,556 | 3,200 | 2,909 | |
| 33 | 16,50 | 11,00 | 8,250 | 6,600 | 5,500 | 4,714 | 4,125 | 3,667 | 3,300 | 3,— | |
| 34 | 17,00 | 11,33 | 8,500 | 6,800 | 5,667 | 4,857 | 4,250 | 3,778 | 3,400 | 3,091 | |
| 35 | 17,50 | 11,67 | 8,750 | 7,— | 5,833 | 5,— | 4,375 | 3,889 | 3,500 | 3,182 | |
| 36 | 18,00 | 12,00 | 9,— | 7,200 | 6,— | 5,143 | 4,500 | 4,— | 3,600 | 3,273 | |

TS/TR TABLE OF INDICATORS (cont.)

| | | TOUCHES RECEIVED | | | | | | | | | | | | | |
|---------|-------|------------------|-------|-------|-------|-------|-------|-------|-------|-------|-------|-------|-------|-------|--|
| | | 12 | 13 | 14 | 15 | 16 | 17 | 18 | 19 | 20 | 21 | 22 | 23 | 24 | |
| TOUCHES | 2 | 0,167 | 0,154 | 0,143 | 0,133 | 0,125 | 0,118 | 0,111 | 0,105 | 0,100 | 0,095 | 0,091 | 0,087 | 0,083 | |
| | 3 | 0,250 | 0,231 | 0,214 | 0,200 | 0,188 | 0,176 | 0,167 | 0,158 | 0,150 | 0,143 | 0,136 | 0,130 | 0,125 | |
| | 4 | 0,333 | 0,308 | 0,286 | 0,267 | 0,250 | 0,235 | 0,222 | 0,211 | 0,200 | 0,190 | 0,182 | 0,174 | 0,167 | |
| | 5 | 0,417 | 0,385 | 0,357 | 0,333 | 0,313 | 0,294 | 0,278 | 0,263 | 0,250 | 0,238 | 0,227 | 0,217 | 0,208 | |
| | 6 | 0,500 | 0,462 | 0,429 | 0,400 | 0,375 | 0,353 | 0,333 | 0,316 | 0,300 | 0,286 | 0,273 | 0,261 | 0,250 | |
| | 7 | 0,583 | 0,538 | 0,500 | 0,467 | 0,438 | 0,412 | 0,389 | 0,368 | 0,350 | 0,333 | 0,318 | 0,304 | 0,292 | |
| | 8 | 0,667 | 0,615 | 0,571 | 0,533 | 0,500 | 0,471 | 0,444 | 0,421 | 0,400 | 0,381 | 0,364 | 0,348 | 0,333 | |
| | 9 | 0,750 | 0,692 | 0,643 | 0,600 | 0,563 | 0,529 | 0,500 | 0,474 | 0,450 | 0,429 | 0,408 | 0,391 | 0,375 | |
| | 10 | 0,833 | 0,769 | 0,714 | 0,667 | 0,625 | 0,588 | 0,556 | 0,526 | 0,500 | 0,476 | 0,455 | 0,435 | 0,417 | |
| | 11 | 0,917 | 0,846 | 0,786 | 0,733 | 0,688 | 0,647 | 0,611 | 0,579 | 0,550 | 0,524 | 0,500 | 0,478 | 0,458 | |
| | 12 | 1 | 0,923 | 0,857 | 0,800 | 0,750 | 0,706 | 0,667 | 0,632 | 0,600 | 0,571 | 0,545 | 0,522 | 0,500 | |
| 13 | 1,083 | 1 | 0,929 | 0,867 | 0,813 | 0,765 | 0,722 | 0,684 | 0,650 | 0,619 | 0,591 | 0,565 | 0,542 | | |
| 14 | 1,167 | 1,077 | 1 | 0,933 | 0,875 | 0,824 | 0,778 | 0,737 | 0,700 | 0,667 | 0,636 | 0,609 | 0,583 | | |
| 15 | 1,250 | 1,154 | 1,071 | 1 | 0,938 | 0,882 | 0,833 | 0,789 | 0,750 | 0,714 | 0,682 | 0,652 | 0,625 | | |
| 16 | 1,333 | 1,231 | 1,143 | 1,067 | 1 | 0,941 | 0,889 | 0,842 | 0,800 | 0,762 | 0,727 | 0,696 | 0,667 | | |
| 17 | 1,417 | 1,308 | 1,214 | 1,133 | 1,063 | 1 | 0,944 | 0,895 | 0,850 | 0,810 | 0,773 | 0,739 | 0,708 | | |
| 18 | 1,500 | 1,385 | 1,286 | 1,200 | 1,125 | 1,059 | 1 | 0,947 | 0,900 | 0,857 | 0,818 | 0,783 | 0,750 | | |
| 19 | 1,583 | 1,462 | 1,357 | 1,267 | 1,188 | 1,118 | 1,056 | 1 | 0,950 | 0,905 | 0,864 | 0,826 | 0,792 | | |
| 20 | 1,667 | 1,538 | 1,429 | 1,333 | 1,250 | 1,176 | 1,111 | 1,053 | 1 | 0,952 | 0,909 | 0,870 | 0,833 | | |
| 21 | 1,750 | 1,615 | 1,500 | 1,400 | 1,313 | 1,235 | 1,167 | 1,105 | 1,050 | 1 | 0,955 | 0,913 | 0,875 | | |
| 22 | 1,833 | 1,692 | 1,571 | 1,467 | 1,375 | 1,294 | 1,222 | 1,158 | 1,100 | 1,048 | 1 | 0,957 | 0,917 | | |
| 23 | 1,917 | 1,769 | 1,643 | 1,533 | 1,438 | 1,353 | 1,278 | 1,211 | 1,150 | 1,095 | 1,045 | 1 | 0,958 | | |
| 24 | 2,— | 1,846 | 1,714 | 1,600 | 1,500 | 1,412 | 1,333 | 1,263 | 1,200 | 1,143 | 1,091 | 1,043 | 1 | | |
| 25 | 2,083 | 1,923 | 1,786 | 1,667 | 1,563 | 1,471 | 1,389 | 1,316 | 1,250 | 1,190 | 1,136 | 1,087 | 1,042 | | |
| 26 | 2,167 | 2,— | 1,857 | 1,733 | 1,625 | 1,529 | 1,444 | 1,368 | 1,300 | 1,238 | 1,182 | 1,130 | 1,083 | | |
| 27 | 2,250 | 2,077 | 1,929 | 1,800 | 1,688 | 1,588 | 1,500 | 1,421 | 1,350 | 1,286 | 1,227 | 1,174 | 1,125 | | |
| 28 | 2,333 | 2,154 | 2,— | 1,867 | 1,750 | 1,647 | 1,556 | 1,474 | 1,400 | 1,333 | 1,273 | 1,217 | 1,167 | | |
| 29 | 2,417 | 2,231 | 2,071 | 1,933 | 1,813 | 1,706 | 1,611 | 1,526 | 1,450 | 1,381 | 1,318 | 1,261 | 1,208 | | |
| 30 | 2,500 | 2,308 | 2,143 | 2,— | 1,875 | 1,765 | 1,667 | 1,579 | 1,500 | 1,429 | 1,364 | 1,304 | 1,250 | | |
| 31 | 2,583 | 2,385 | 2,214 | 2,067 | 1,938 | 1,824 | 1,722 | 1,632 | 1,550 | 1,476 | 1,409 | 1,348 | 1,292 | | |
| 32 | 2,667 | 2,462 | 2,286 | 2,133 | 2,— | 1,882 | 1,778 | 1,684 | 1,600 | 1,524 | 1,455 | 1,391 | 1,333 | | |
| 33 | 2,750 | 2,538 | 2,357 | 2,200 | 2,063 | 1,941 | 1,833 | 1,737 | 1,650 | 1,571 | 1,500 | 1,435 | 1,375 | | |
| 34 | 2,833 | 2,615 | 2,429 | 2,267 | 2,125 | 2,— | 1,889 | 1,789 | 1,700 | 1,619 | 1,545 | 1,478 | 1,417 | | |
| 35 | 2,917 | 2,692 | 2,500 | 2,333 | 2,188 | 2,059 | 1,944 | 1,842 | 1,750 | 1,667 | 1,591 | 1,522 | 1,458 | | |
| 36 | 3,— | 2,769 | 2,571 | 2,400 | 2,250 | 2,118 | 2,— | 1,895 | 1,800 | 1,714 | 1,636 | 1,565 | 1,500 | | |

FENCING RULES FOR COMPETITION

TS/TR TABLE OF INDICATORS (cont.)

| | | TOUCHES RECEIVED | | | | | | | | | | | | | |
|---------|-------|------------------|-------|-------|-------|-------|-------|-------|-------|-------|-------|-------|--|--|--|
| | | 25 | 26 | 27 | 28 | 29 | 30 | 31 | 32 | 33 | 34 | 35 | | | |
| TOUCHES | 2 | 0,080 | 0,077 | 0,074 | 0,071 | 0,069 | 0,067 | 0,065 | 0,063 | 0,061 | 0,059 | 0,057 | | | |
| | 3 | 0,120 | 0,115 | 0,111 | 0,107 | 0,103 | 0,100 | 0,097 | 0,094 | 0,091 | 0,088 | 0,086 | | | |
| | 4 | 0,160 | 0,154 | 0,148 | 0,143 | 0,138 | 0,133 | 0,129 | 0,125 | 0,121 | 0,118 | 0,114 | | | |
| | 5 | 0,200 | 0,192 | 0,185 | 0,179 | 0,172 | 0,167 | 0,161 | 0,156 | 0,152 | 0,147 | 0,143 | | | |
| | 6 | 0,240 | 0,231 | 0,222 | 0,214 | 0,207 | 0,200 | 0,194 | 0,188 | 0,182 | 0,178 | 0,171 | | | |
| | 7 | 0,280 | 0,269 | 0,259 | 0,250 | 0,241 | 0,233 | 0,226 | 0,219 | 0,212 | 0,206 | 0,200 | | | |
| | 8 | 0,320 | 0,308 | 0,296 | 0,286 | 0,278 | 0,267 | 0,258 | 0,250 | 0,242 | 0,235 | 0,229 | | | |
| | 9 | 0,360 | 0,346 | 0,333 | 0,321 | 0,310 | 0,300 | 0,290 | 0,281 | 0,273 | 0,265 | 0,257 | | | |
| | 10 | 0,400 | 0,385 | 0,370 | 0,357 | 0,345 | 0,333 | 0,323 | 0,313 | 0,303 | 0,294 | 0,286 | | | |
| | 11 | 0,440 | 0,423 | 0,407 | 0,393 | 0,379 | 0,367 | 0,355 | 0,344 | 0,333 | 0,324 | 0,314 | | | |
| 12 | 0,480 | 0,462 | 0,444 | 0,429 | 0,414 | 0,400 | 0,387 | 0,375 | 0,364 | 0,353 | 0,343 | | | | |
| 13 | 0,520 | 0,500 | 0,481 | 0,464 | 0,448 | 0,433 | 0,419 | 0,406 | 0,394 | 0,382 | 0,371 | | | | |
| 14 | 0,560 | 0,538 | 0,519 | 0,500 | 0,483 | 0,467 | 0,452 | 0,438 | 0,424 | 0,412 | 0,400 | | | | |
| 15 | 0,600 | 0,577 | 0,556 | 0,536 | 0,517 | 0,500 | 0,484 | 0,469 | 0,455 | 0,441 | 0,429 | | | | |
| 16 | 0,640 | 0,615 | 0,593 | 0,571 | 0,552 | 0,533 | 0,516 | 0,500 | 0,485 | 0,471 | 0,457 | | | | |
| 17 | 0,680 | 0,654 | 0,630 | 0,607 | 0,586 | 0,567 | 0,548 | 0,531 | 0,515 | 0,500 | 0,486 | | | | |
| 18 | 0,720 | 0,692 | 0,667 | 0,643 | 0,621 | 0,600 | 0,581 | 0,563 | 0,545 | 0,529 | 0,514 | | | | |
| 19 | 0,760 | 0,731 | 0,704 | 0,679 | 0,655 | 0,633 | 0,613 | 0,594 | 0,576 | 0,559 | 0,543 | | | | |
| 20 | 0,800 | 0,769 | 0,741 | 0,714 | 0,690 | 0,667 | 0,645 | 0,625 | 0,606 | 0,588 | 0,571 | | | | |
| 21 | 0,840 | 0,808 | 0,778 | 0,750 | 0,724 | 0,700 | 0,677 | 0,656 | 0,636 | 0,618 | 0,600 | | | | |
| 22 | 0,880 | 0,846 | 0,815 | 0,786 | 0,759 | 0,733 | 0,710 | 0,688 | 0,667 | 0,647 | 0,629 | | | | |
| 23 | 0,920 | 0,885 | 0,852 | 0,821 | 0,793 | 0,767 | 0,742 | 0,719 | 0,697 | 0,676 | 0,657 | | | | |
| 24 | 0,960 | 0,923 | 0,889 | 0,857 | 0,826 | 0,800 | 0,774 | 0,750 | 0,727 | 0,706 | 0,686 | | | | |
| 25 | 1 | 0,962 | 0,926 | 0,893 | 0,862 | 0,833 | 0,806 | 0,781 | 0,758 | 0,735 | 0,714 | | | | |
| 26 | 1,040 | 1 | 0,963 | 0,929 | 0,897 | 0,867 | 0,839 | 0,813 | 0,788 | 0,765 | 0,743 | | | | |
| 27 | 1,080 | 1,038 | 1 | 0,964 | 0,931 | 0,900 | 0,871 | 0,844 | 0,818 | 0,794 | 0,771 | | | | |
| 28 | 1,120 | 1,077 | 1,037 | 1 | 0,966 | 0,933 | 0,903 | 0,875 | 0,848 | 0,824 | 0,800 | | | | |
| 29 | 1,160 | 1,115 | 1,074 | 1,036 | 1 | 0,967 | 0,935 | 0,906 | 0,879 | 0,853 | 0,829 | | | | |
| 30 | 1,200 | 1,154 | 1,111 | 1,071 | 1,034 | 1 | 0,968 | 0,938 | 0,909 | 0,882 | 0,857 | | | | |
| 31 | 1,240 | 1,192 | 1,148 | 1,107 | 1,069 | 1,033 | 1 | 0,969 | 0,939 | 0,912 | 0,886 | | | | |
| 32 | 1,280 | 1,231 | 1,185 | 1,143 | 1,103 | 1,067 | 1,032 | 1 | 0,970 | 0,941 | 0,914 | | | | |
| 33 | 1,320 | 1,269 | 1,222 | 1,179 | 1,138 | 1,100 | 1,065 | 1,031 | 1 | 0,971 | 0,943 | | | | |
| 34 | 1,360 | 1,308 | 1,259 | 1,214 | 1,172 | 1,133 | 1,097 | 1,063 | 1,030 | 1 | 0,971 | | | | |
| 35 | 1,400 | 1,346 | 1,296 | 1,250 | 1,207 | 1,167 | 1,129 | 1,094 | 1,061 | 1,029 | 1 | | | | |
| 36 | 1,440 | 1,385 | 1,333 | 1,286 | 1,241 | 1,200 | 1,161 | 1,125 | 1,091 | 1,059 | 1,029 | | | | |

TS/TR TABLE OF INDICATORS (cont.)

| | | TOUCHES RECEIVED | | | | | | | | | | | | |
|----------------|----|------------------|-------|-------|-------|-------|-------|-------|-------|-------|-------|-------|--|--|
| | | 36 | 37 | 38 | 39 | 40 | 41 | 42 | 43 | 44 | 45 | 46 | | |
| TOUCHES SCORED | 2 | 0,056 | 0,054 | 0,053 | 0,051 | 0,050 | 0,049 | 0,048 | 0,047 | 0,045 | 0,044 | 0,043 | | |
| | 3 | 0,083 | 0,081 | 0,079 | 0,077 | 0,075 | 0,073 | 0,071 | 0,070 | 0,068 | 0,067 | 0,065 | | |
| | 4 | 0,111 | 0,108 | 0,105 | 0,103 | 0,100 | 0,098 | 0,095 | 0,093 | 0,091 | 0,089 | 0,087 | | |
| | 5 | 0,139 | 0,135 | 0,132 | 0,128 | 0,125 | 0,122 | 0,119 | 0,116 | 0,114 | 0,111 | 0,109 | | |
| | 6 | 0,167 | 0,162 | 0,158 | 0,154 | 0,150 | 0,146 | 0,143 | 0,140 | 0,136 | 0,133 | 0,130 | | |
| | 7 | 0,194 | 0,189 | 0,184 | 0,179 | 0,175 | 0,171 | 0,167 | 0,163 | 0,159 | 0,156 | 0,152 | | |
| | 8 | 0,222 | 0,216 | 0,211 | 0,205 | 0,200 | 0,195 | 0,190 | 0,186 | 0,182 | 0,178 | 0,174 | | |
| | 9 | 0,250 | 0,243 | 0,237 | 0,231 | 0,225 | 0,220 | 0,214 | 0,209 | 0,205 | 0,200 | 0,196 | | |
| | 10 | 0,278 | 0,270 | 0,263 | 0,256 | 0,250 | 0,244 | 0,238 | 0,233 | 0,227 | 0,222 | 0,217 | | |
| | 11 | 0,306 | 0,297 | 0,289 | 0,282 | 0,275 | 0,268 | 0,262 | 0,256 | 0,250 | 0,244 | 0,239 | | |
| | 12 | 0,333 | 0,324 | 0,316 | 0,308 | 0,300 | 0,293 | 0,286 | 0,279 | 0,273 | 0,267 | 0,261 | | |
| | 13 | 0,361 | 0,351 | 0,342 | 0,333 | 0,325 | 0,317 | 0,310 | 0,302 | 0,295 | 0,289 | 0,283 | | |
| | 14 | 0,389 | 0,378 | 0,368 | 0,359 | 0,350 | 0,341 | 0,333 | 0,326 | 0,318 | 0,311 | 0,304 | | |
| | 15 | 0,417 | 0,405 | 0,395 | 0,385 | 0,375 | 0,366 | 0,357 | 0,349 | 0,341 | 0,333 | 0,326 | | |
| | 16 | 0,444 | 0,432 | 0,421 | 0,410 | 0,400 | 0,390 | 0,381 | 0,372 | 0,364 | 0,356 | 0,348 | | |
| | 17 | 0,472 | 0,459 | 0,447 | 0,436 | 0,425 | 0,415 | 0,405 | 0,395 | 0,386 | 0,378 | 0,370 | | |
| | 18 | 0,500 | 0,486 | 0,474 | 0,462 | 0,450 | 0,439 | 0,429 | 0,419 | 0,409 | 0,400 | 0,391 | | |
| | 19 | 0,528 | 0,514 | 0,500 | 0,487 | 0,475 | 0,463 | 0,452 | 0,442 | 0,432 | 0,422 | 0,413 | | |
| | 20 | 0,556 | 0,541 | 0,526 | 0,513 | 0,500 | 0,488 | 0,476 | 0,465 | 0,455 | 0,444 | 0,435 | | |
| | 21 | 0,583 | 0,568 | 0,553 | 0,538 | 0,525 | 0,512 | 0,500 | 0,488 | 0,477 | 0,467 | 0,457 | | |
| | 22 | 0,611 | 0,595 | 0,579 | 0,564 | 0,550 | 0,537 | 0,524 | 0,512 | 0,500 | 0,489 | 0,478 | | |
| | 23 | 0,639 | 0,622 | 0,605 | 0,590 | 0,575 | 0,561 | 0,548 | 0,535 | 0,523 | 0,511 | 0,500 | | |
| | 24 | 0,667 | 0,649 | 0,632 | 0,615 | 0,600 | 0,585 | 0,571 | 0,558 | 0,545 | 0,533 | 0,522 | | |
| | 25 | 0,694 | 0,676 | 0,658 | 0,641 | 0,625 | 0,610 | 0,595 | 0,581 | 0,568 | 0,556 | 0,543 | | |
| | 26 | 0,722 | 0,703 | 0,684 | 0,667 | 0,650 | 0,634 | 0,619 | 0,605 | 0,591 | 0,578 | 0,565 | | |
| | 27 | 0,750 | 0,730 | 0,711 | 0,692 | 0,675 | 0,659 | 0,643 | 0,628 | 0,614 | 0,600 | 0,587 | | |
| | 28 | 0,778 | 0,757 | 0,737 | 0,718 | 0,700 | 0,683 | 0,667 | 0,651 | 0,636 | 0,622 | 0,609 | | |
| | 29 | 0,806 | 0,784 | 0,763 | 0,744 | 0,725 | 0,707 | 0,690 | 0,674 | 0,659 | 0,644 | 0,630 | | |
| | 30 | 0,833 | 0,811 | 0,789 | 0,769 | 0,750 | 0,732 | 0,714 | 0,698 | 0,682 | 0,667 | 0,652 | | |
| | 31 | 0,861 | 0,838 | 0,816 | 0,795 | 0,775 | 0,756 | 0,738 | 0,721 | 0,705 | 0,689 | 0,674 | | |
| | 32 | 0,889 | 0,865 | 0,842 | 0,821 | 0,800 | 0,780 | 0,762 | 0,744 | 0,727 | 0,711 | 0,696 | | |
| | 33 | 0,917 | 0,892 | 0,868 | 0,846 | 0,825 | 0,805 | 0,786 | 0,767 | 0,750 | 0,733 | 0,717 | | |
| | 34 | 0,944 | 0,919 | 0,895 | 0,872 | 0,850 | 0,829 | 0,810 | 0,791 | 0,773 | 0,756 | 0,739 | | |
| | 35 | 0,972 | 0,946 | 0,921 | 0,897 | 0,875 | 0,854 | 0,833 | 0,814 | 0,795 | 0,778 | 0,761 | | |
| | 36 | 1 | 0,973 | 0,947 | 0,923 | 0,900 | 0,878 | 0,857 | 0,837 | 0,818 | 0,800 | 0,783 | | |

TS/TR TABLE OF INDICATORS (cont.)

| | | TOUCHES RECEIVED | | | | | | | | | | | |
|---------------------------------|-------|------------------|-------|-------|-------|-------|-------|-------|-------|-------|-------|-------|-------|
| | | 47 | 48 | 49 | 50 | 51 | 52 | 53 | 54 | 55 | 56 | 57 | 58 |
| T O U C H E S | 2 | 0,043 | 0,042 | 0,041 | 0,040 | 0,039 | 0,038 | 0,038 | 0,037 | 0,036 | 0,036 | 0,035 | 0,034 |
| | 3 | 0,064 | 0,063 | 0,061 | 0,060 | 0,059 | 0,058 | 0,057 | 0,056 | 0,055 | 0,054 | 0,053 | 0,052 |
| | 4 | 0,085 | 0,083 | 0,082 | 0,080 | 0,078 | 0,077 | 0,075 | 0,074 | 0,073 | 0,071 | 0,070 | 0,069 |
| | 5 | 0,106 | 0,104 | 0,102 | 0,100 | 0,098 | 0,096 | 0,094 | 0,093 | 0,091 | 0,089 | 0,088 | 0,086 |
| | 6 | 0,128 | 0,125 | 0,122 | 0,120 | 0,118 | 0,115 | 0,113 | 0,111 | 0,109 | 0,107 | 0,105 | 0,103 |
| | 7 | 0,149 | 0,146 | 0,143 | 0,140 | 0,137 | 0,135 | 0,132 | 0,130 | 0,127 | 0,125 | 0,123 | 0,121 |
| | 8 | 0,170 | 0,167 | 0,163 | 0,160 | 0,157 | 0,154 | 0,151 | 0,148 | 0,145 | 0,143 | 0,140 | 0,138 |
| | 9 | 0,191 | 0,188 | 0,184 | 0,180 | 0,176 | 0,173 | 0,170 | 0,167 | 0,164 | 0,161 | 0,158 | 0,155 |
| | 10 | 0,213 | 0,208 | 0,204 | 0,200 | 0,196 | 0,192 | 0,189 | 0,185 | 0,182 | 0,179 | 0,175 | 0,172 |
| | 11 | 0,234 | 0,229 | 0,224 | 0,220 | 0,216 | 0,212 | 0,208 | 0,204 | 0,200 | 0,196 | 0,193 | 0,190 |
| 12 | 0,255 | 0,250 | 0,245 | 0,240 | 0,235 | 0,231 | 0,226 | 0,222 | 0,218 | 0,214 | 0,211 | 0,207 | |
| 13 | 0,277 | 0,271 | 0,265 | 0,260 | 0,255 | 0,250 | 0,245 | 0,241 | 0,236 | 0,232 | 0,228 | 0,224 | |
| 14 | 0,298 | 0,292 | 0,286 | 0,280 | 0,275 | 0,269 | 0,264 | 0,259 | 0,255 | 0,250 | 0,246 | 0,241 | |
| 15 | 0,319 | 0,313 | 0,306 | 0,300 | 0,294 | 0,288 | 0,283 | 0,278 | 0,273 | 0,268 | 0,263 | 0,259 | |
| S C O R E D | 16 | 0,340 | 0,333 | 0,327 | 0,320 | 0,314 | 0,308 | 0,302 | 0,296 | 0,291 | 0,286 | 0,281 | 0,276 |
| | 17 | 0,362 | 0,354 | 0,347 | 0,340 | 0,333 | 0,327 | 0,321 | 0,315 | 0,309 | 0,304 | 0,298 | 0,293 |
| | 18 | 0,383 | 0,375 | 0,367 | 0,360 | 0,353 | 0,346 | 0,340 | 0,333 | 0,327 | 0,321 | 0,316 | 0,310 |
| | 19 | 0,404 | 0,396 | 0,388 | 0,380 | 0,373 | 0,365 | 0,358 | 0,352 | 0,345 | 0,339 | 0,333 | 0,328 |
| | 20 | 0,426 | 0,417 | 0,408 | 0,400 | 0,392 | 0,385 | 0,377 | 0,370 | 0,364 | 0,357 | 0,351 | 0,345 |
| | 21 | 0,447 | 0,438 | 0,429 | 0,420 | 0,412 | 0,404 | 0,396 | 0,389 | 0,382 | 0,375 | 0,368 | 0,362 |
| | 22 | 0,468 | 0,458 | 0,449 | 0,440 | 0,431 | 0,423 | 0,415 | 0,407 | 0,400 | 0,393 | 0,386 | 0,379 |
| | 23 | 0,489 | 0,479 | 0,469 | 0,460 | 0,451 | 0,442 | 0,434 | 0,426 | 0,418 | 0,411 | 0,404 | 0,397 |
| | 24 | 0,511 | 0,500 | 0,490 | 0,480 | 0,471 | 0,462 | 0,453 | 0,444 | 0,436 | 0,429 | 0,421 | 0,414 |
| | 25 | 0,532 | 0,521 | 0,510 | 0,500 | 0,490 | 0,481 | 0,472 | 0,463 | 0,455 | 0,446 | 0,439 | 0,431 |
| 26 | 0,553 | 0,542 | 0,531 | 0,520 | 0,510 | 0,500 | 0,491 | 0,481 | 0,473 | 0,464 | 0,456 | 0,448 | |
| 27 | 0,574 | 0,563 | 0,551 | 0,540 | 0,529 | 0,519 | 0,509 | 0,500 | 0,491 | 0,482 | 0,474 | 0,466 | |
| 28 | 0,596 | 0,583 | 0,571 | 0,560 | 0,549 | 0,538 | 0,528 | 0,519 | 0,509 | 0,500 | 0,491 | 0,483 | |
| 29 | 0,617 | 0,604 | 0,592 | 0,580 | 0,569 | 0,558 | 0,547 | 0,537 | 0,527 | 0,518 | 0,509 | 0,500 | |
| 30 | 0,638 | 0,625 | 0,612 | 0,600 | 0,588 | 0,577 | 0,566 | 0,556 | 0,545 | 0,536 | 0,528 | 0,517 | |
| 31 | 0,660 | 0,646 | 0,633 | 0,620 | 0,608 | 0,596 | 0,585 | 0,574 | 0,564 | 0,554 | 0,544 | 0,534 | |
| 32 | 0,681 | 0,667 | 0,653 | 0,640 | 0,627 | 0,615 | 0,604 | 0,593 | 0,582 | 0,571 | 0,561 | 0,552 | |
| 33 | 0,702 | 0,688 | 0,673 | 0,660 | 0,647 | 0,635 | 0,623 | 0,611 | 0,600 | 0,589 | 0,579 | 0,569 | |
| 34 | 0,723 | 0,708 | 0,694 | 0,680 | 0,667 | 0,654 | 0,642 | 0,630 | 0,618 | 0,607 | 0,596 | 0,586 | |
| 35 | 0,745 | 0,729 | 0,714 | 0,700 | 0,686 | 0,673 | 0,660 | 0,648 | 0,636 | 0,625 | 0,614 | 0,603 | |
| 36 | 0,766 | 0,750 | 0,735 | 0,720 | 0,706 | 0,692 | 0,679 | 0,667 | 0,655 | 0,643 | 0,632 | 0,621 | |

TS/TR TABLE OF INDICATORS (cont.)

| | | TOUCHES RECEIVED | | | | | | | | | | | |
|---------------------------------|-------|------------------|-------|-------|-------|-------|-------|-------|-------|-------|-------|-------|-------|
| | | 59 | 60 | 61 | 62 | 63 | 64 | 65 | 66 | 67 | 68 | 69 | 70 |
| T O U C H E S | 2 | 0,034 | 0,033 | 0,033 | 0,032 | 0,032 | 0,031 | 0,031 | 0,030 | 0,030 | 0,029 | 0,029 | 0,029 |
| | 3 | 0,051 | 0,050 | 0,049 | 0,048 | 0,048 | 0,047 | 0,046 | 0,045 | 0,045 | 0,044 | 0,043 | 0,043 |
| | 4 | 0,068 | 0,067 | 0,066 | 0,065 | 0,063 | 0,063 | 0,062 | 0,061 | 0,060 | 0,059 | 0,058 | 0,057 |
| | 5 | 0,085 | 0,083 | 0,082 | 0,081 | 0,079 | 0,078 | 0,077 | 0,076 | 0,075 | 0,074 | 0,072 | 0,071 |
| | 6 | 0,102 | 0,100 | 0,098 | 0,097 | 0,095 | 0,094 | 0,092 | 0,091 | 0,090 | 0,088 | 0,087 | 0,086 |
| | 7 | 0,119 | 0,117 | 0,115 | 0,113 | 0,111 | 0,109 | 0,108 | 0,106 | 0,104 | 0,103 | 0,101 | 0,100 |
| | 8 | 0,136 | 0,133 | 0,131 | 0,129 | 0,127 | 0,125 | 0,123 | 0,121 | 0,119 | 0,118 | 0,116 | 0,114 |
| | 9 | 0,153 | 0,150 | 0,148 | 0,145 | 0,143 | 0,141 | 0,138 | 0,136 | 0,134 | 0,132 | 0,130 | 0,129 |
| | 10 | 0,169 | 0,167 | 0,164 | 0,161 | 0,159 | 0,156 | 0,154 | 0,152 | 0,149 | 0,147 | 0,145 | 0,143 |
| | 11 | 0,186 | 0,183 | 0,180 | 0,177 | 0,175 | 0,172 | 0,169 | 0,167 | 0,164 | 0,162 | 0,159 | 0,157 |
| 12 | 0,203 | 0,200 | 0,197 | 0,194 | 0,190 | 0,188 | 0,185 | 0,182 | 0,179 | 0,176 | 0,174 | 0,171 | |
| 13 | 0,220 | 0,217 | 0,213 | 0,210 | 0,206 | 0,203 | 0,200 | 0,197 | 0,194 | 0,191 | 0,188 | 0,186 | |
| 14 | 0,237 | 0,233 | 0,230 | 0,226 | 0,222 | 0,219 | 0,215 | 0,212 | 0,209 | 0,206 | 0,203 | 0,200 | |
| 15 | 0,254 | 0,250 | 0,246 | 0,242 | 0,238 | 0,234 | 0,231 | 0,227 | 0,224 | 0,221 | 0,217 | 0,214 | |
| 16 | 0,271 | 0,267 | 0,262 | 0,258 | 0,254 | 0,250 | 0,246 | 0,242 | 0,239 | 0,235 | 0,232 | 0,229 | |
| 17 | 0,288 | 0,283 | 0,279 | 0,274 | 0,270 | 0,266 | 0,262 | 0,258 | 0,254 | 0,250 | 0,246 | 0,243 | |
| 18 | 0,305 | 0,300 | 0,295 | 0,290 | 0,286 | 0,281 | 0,277 | 0,273 | 0,269 | 0,265 | 0,261 | 0,257 | |
| 19 | 0,322 | 0,317 | 0,311 | 0,306 | 0,302 | 0,297 | 0,292 | 0,288 | 0,284 | 0,279 | 0,275 | 0,271 | |
| 20 | 0,339 | 0,333 | 0,328 | 0,323 | 0,317 | 0,313 | 0,308 | 0,303 | 0,299 | 0,294 | 0,290 | 0,286 | |
| 21 | 0,356 | 0,350 | 0,344 | 0,339 | 0,333 | 0,328 | 0,323 | 0,318 | 0,313 | 0,309 | 0,304 | 0,300 | |
| 22 | 0,373 | 0,367 | 0,361 | 0,355 | 0,349 | 0,344 | 0,338 | 0,333 | 0,328 | 0,324 | 0,319 | 0,314 | |
| 23 | 0,390 | 0,383 | 0,377 | 0,371 | 0,365 | 0,359 | 0,354 | 0,348 | 0,343 | 0,338 | 0,333 | 0,329 | |
| 24 | 0,407 | 0,400 | 0,393 | 0,387 | 0,381 | 0,375 | 0,369 | 0,364 | 0,358 | 0,353 | 0,348 | 0,343 | |
| 25 | 0,424 | 0,417 | 0,410 | 0,403 | 0,397 | 0,391 | 0,385 | 0,379 | 0,373 | 0,368 | 0,362 | 0,357 | |
| 26 | 0,441 | 0,433 | 0,426 | 0,419 | 0,413 | 0,406 | 0,400 | 0,394 | 0,388 | 0,382 | 0,377 | 0,371 | |
| 27 | 0,458 | 0,450 | 0,443 | 0,435 | 0,429 | 0,422 | 0,415 | 0,409 | 0,403 | 0,397 | 0,391 | 0,386 | |
| 28 | 0,475 | 0,467 | 0,459 | 0,452 | 0,444 | 0,438 | 0,431 | 0,424 | 0,418 | 0,412 | 0,406 | 0,400 | |
| 29 | 0,492 | 0,483 | 0,475 | 0,468 | 0,460 | 0,453 | 0,446 | 0,439 | 0,433 | 0,426 | 0,420 | 0,414 | |
| 30 | 0,508 | 0,500 | 0,492 | 0,484 | 0,476 | 0,469 | 0,462 | 0,455 | 0,448 | 0,441 | 0,435 | 0,429 | |
| 31 | 0,525 | 0,517 | 0,508 | 0,500 | 0,492 | 0,484 | 0,477 | 0,470 | 0,463 | 0,456 | 0,449 | 0,443 | |
| 32 | 0,542 | 0,533 | 0,525 | 0,516 | 0,508 | 0,500 | 0,492 | 0,485 | 0,478 | 0,471 | 0,464 | 0,457 | |
| 33 | 0,559 | 0,550 | 0,541 | 0,532 | 0,524 | 0,516 | 0,508 | 0,500 | 0,493 | 0,485 | 0,478 | 0,471 | |
| 34 | 0,576 | 0,567 | 0,557 | 0,548 | 0,540 | 0,531 | 0,523 | 0,515 | 0,507 | 0,500 | 0,493 | 0,486 | |
| 35 | 0,593 | 0,583 | 0,574 | 0,565 | 0,556 | 0,547 | 0,538 | 0,530 | 0,522 | 0,515 | 0,507 | 0,500 | |
| 36 | 0,610 | 0,600 | 0,590 | 0,581 | 0,571 | 0,563 | 0,554 | 0,545 | 0,537 | 0,529 | 0,522 | 0,514 | |

TS/TR TABLE OF INDICATORS (cont.)

| | | TOUCHES RECEIVED | | | | | | | | | |
|----------------|-------|------------------|-------|-------|-------|-------|-------|-------|-------|-------|-------|
| | | 2 | 3 | 4 | 5 | 6 | 7 | 8 | 9 | 10 | 11 |
| TOUCHES SCORED | 37 | 18,50 | 12,33 | 9,250 | 7,400 | 6,167 | 5,286 | 4,625 | 4,111 | 3,700 | 3,364 |
| | 38 | 19,00 | 12,67 | 9,500 | 7,600 | 6,333 | 5,429 | 4,750 | 4,222 | 3,800 | 3,455 |
| | 39 | 19,50 | 13,00 | 9,750 | 7,800 | 6,500 | 5,571 | 4,875 | 4,333 | 3,900 | 3,545 |
| | 40 | 20,00 | 13,33 | 10,00 | 8,— | 6,667 | 5,714 | 5,— | 4,444 | 4,— | 3,636 |
| | 41 | 20,50 | 13,67 | 10,25 | 8,200 | 6,833 | 5,857 | 5,125 | 4,556 | 4,100 | 3,727 |
| | 42 | 21,00 | 14,00 | 10,50 | 8,400 | 7,— | 6,— | 5,250 | 4,667 | 4,200 | 3,818 |
| | 43 | 21,50 | 14,33 | 10,75 | 8,600 | 7,167 | 6,143 | 5,375 | 4,778 | 4,300 | 3,909 |
| | 44 | 22,00 | 14,67 | 11,00 | 8,800 | 7,333 | 6,286 | 5,500 | 4,889 | 4,400 | 4,— |
| | 45 | 22,50 | 15,00 | 11,25 | 9,— | 7,500 | 6,429 | 5,625 | 5,— | 4,500 | 4,091 |
| | 46 | 23,00 | 15,33 | 11,50 | 9,200 | 7,667 | 6,571 | 5,750 | 5,111 | 4,600 | 4,182 |
| | 47 | 23,50 | 15,67 | 11,75 | 9,400 | 7,833 | 6,714 | 5,875 | 5,222 | 4,700 | 4,273 |
| | 48 | 24,00 | 16,00 | 12,00 | 9,600 | 8,— | 6,857 | 6,— | 5,333 | 4,800 | 4,364 |
| | 49 | 24,50 | 16,33 | 12,25 | 9,800 | 8,167 | 7,— | 6,125 | 5,444 | 4,900 | 4,455 |
| | 50 | 25,00 | 16,67 | 12,50 | 10,00 | 8,333 | 7,143 | 6,250 | 5,556 | 5,— | 4,545 |
| | 51 | 25,50 | 17,00 | 12,75 | 10,20 | 8,500 | 7,286 | 6,375 | 5,667 | 5,100 | 4,636 |
| | 52 | 26,00 | 17,33 | 13,00 | 10,40 | 8,667 | 7,429 | 6,500 | 5,778 | 5,200 | 4,727 |
| | 53 | 26,50 | 17,67 | 13,25 | 10,60 | 8,833 | 7,571 | 6,625 | 5,889 | 5,300 | 4,818 |
| | 54 | 27,00 | 18,00 | 13,50 | 10,80 | 9,— | 7,714 | 6,750 | 6,— | 5,400 | 4,909 |
| | 55 | 27,50 | 18,33 | 13,75 | 11,00 | 9,167 | 7,857 | 6,875 | 6,111 | 5,500 | 5,— |
| | 56 | 28,00 | 18,67 | 14,00 | 11,20 | 9,333 | 8,— | 7,— | 6,222 | 5,600 | 5,091 |
| 57 | 28,50 | 19,00 | 14,25 | 11,40 | 9,500 | 8,143 | 7,125 | 6,333 | 5,700 | 5,182 | |
| 58 | 29,00 | 19,33 | 14,50 | 11,60 | 9,667 | 8,286 | 7,250 | 6,444 | 5,800 | 5,273 | |
| 59 | 29,50 | 19,67 | 14,75 | 11,80 | 9,833 | 8,429 | 7,375 | 6,556 | 5,900 | 5,364 | |
| 60 | 30,00 | 20,00 | 15,00 | 12,00 | 10,00 | 8,571 | 7,500 | 6,667 | 6,— | 5,455 | |
| 61 | 30,50 | 20,33 | 15,25 | 12,20 | 10,17 | 8,714 | 7,625 | 6,778 | 6,100 | 5,545 | |
| 62 | 31,00 | 20,67 | 15,50 | 12,40 | 10,33 | 8,857 | 7,750 | 6,889 | 6,200 | 5,636 | |
| 63 | 31,50 | 21,00 | 15,75 | 12,60 | 10,50 | 9,— | 7,875 | 7,— | 6,300 | 5,727 | |
| 64 | 32,00 | 21,33 | 16,00 | 12,80 | 10,67 | 9,143 | 8,— | 7,111 | 6,400 | 5,818 | |
| 65 | 32,50 | 21,67 | 16,25 | 13,00 | 10,83 | 9,286 | 8,125 | 7,222 | 6,500 | 5,909 | |
| 66 | 33,00 | 22,00 | 16,50 | 13,20 | 11,00 | 9,429 | 8,250 | 7,333 | 6,600 | 6,— | |
| 67 | 33,50 | 22,33 | 16,75 | 13,40 | 11,17 | 9,571 | 8,375 | 7,444 | 6,700 | 6,091 | |
| 68 | 34,00 | 22,67 | 17,00 | 13,60 | 11,33 | 9,714 | 8,500 | 7,556 | 6,800 | 6,182 | |
| 69 | 34,50 | 23,00 | 17,25 | 13,80 | 11,50 | 9,857 | 8,625 | 7,667 | 6,900 | 6,273 | |
| 70 | 35,00 | 23,33 | 17,50 | 14,00 | 11,67 | 10,00 | 8,750 | 7,778 | 7,— | 6,364 | |

TS/TR TABLE OF INDICATORS (cont.)

| | | TOUCHES RECEIVED | | | | | | | | | | | | |
|----------------|-------|------------------|-------|-------|-------|-------|-------|-------|-------|-------|-------|-------|-------|-------|
| | | 12 | 13 | 14 | 15 | 16 | 17 | 18 | 19 | 20 | 21 | 22 | 23 | 24 |
| TOUCHES SCORED | 37 | 3,083 | 2,846 | 2,643 | 2,467 | 2,313 | 2,176 | 2,056 | 1,947 | 1,850 | 1,762 | 1,682 | 1,609 | 1,542 |
| | 38 | 3,167 | 2,923 | 2,714 | 2,533 | 2,375 | 2,235 | 2,111 | 2,— | 1,900 | 1,810 | 1,727 | 1,652 | 1,583 |
| | 39 | 3,250 | 3,— | 2,786 | 2,600 | 2,438 | 2,294 | 2,167 | 2,053 | 1,950 | 1,857 | 1,773 | 1,696 | 1,625 |
| | 40 | 3,333 | 3,077 | 2,857 | 2,667 | 2,500 | 2,353 | 2,222 | 2,105 | 2,— | 1,965 | 1,818 | 1,739 | 1,667 |
| | 41 | 3,417 | 3,154 | 2,929 | 2,733 | 2,563 | 2,412 | 2,278 | 2,158 | 2,050 | 1,952 | 1,864 | 1,783 | 1,708 |
| | 42 | 3,500 | 3,231 | 3,— | 2,800 | 2,625 | 2,471 | 2,333 | 2,211 | 2,100 | 2,— | 1,909 | 1,826 | 1,750 |
| | 43 | 3,583 | 3,308 | 3,071 | 2,867 | 2,688 | 2,529 | 2,389 | 2,263 | 2,150 | 2,048 | 1,955 | 1,870 | 1,792 |
| | 44 | 3,667 | 3,385 | 3,143 | 2,933 | 2,750 | 2,588 | 2,444 | 2,316 | 2,200 | 2,095 | 2,— | 1,913 | 1,833 |
| | 45 | 3,750 | 3,462 | 3,214 | 3,— | 2,813 | 2,647 | 2,500 | 2,368 | 2,250 | 2,143 | 2,045 | 1,957 | 1,875 |
| | 46 | 3,833 | 3,533 | 3,286 | 3,067 | 2,875 | 2,708 | 2,556 | 2,421 | 2,300 | 2,190 | 2,091 | 2,— | 1,917 |
| | 47 | 3,917 | 3,615 | 3,357 | 3,133 | 2,938 | 2,765 | 2,611 | 2,474 | 2,350 | 2,238 | 2,136 | 2,043 | 1,958 |
| | 48 | 4,— | 3,692 | 3,429 | 3,200 | 3,— | 2,824 | 2,667 | 2,526 | 2,400 | 2,286 | 2,182 | 2,087 | 2,— |
| | 49 | 4,083 | 3,769 | 3,500 | 3,267 | 3,063 | 2,882 | 2,722 | 2,579 | 2,450 | 2,333 | 2,227 | 2,130 | 2,042 |
| | 50 | 4,167 | 3,846 | 3,571 | 3,333 | 3,125 | 2,941 | 2,778 | 2,632 | 2,500 | 2,381 | 2,273 | 2,174 | 2,083 |
| | 51 | 4,250 | 3,923 | 3,643 | 3,400 | 3,188 | 3,— | 2,833 | 2,684 | 2,550 | 2,429 | 2,318 | 2,217 | 2,125 |
| | 52 | 4,333 | 4,— | 3,714 | 3,467 | 3,250 | 3,059 | 2,889 | 2,737 | 2,600 | 2,476 | 2,364 | 2,261 | 2,167 |
| | 53 | 4,417 | 4,077 | 3,786 | 3,533 | 3,313 | 3,118 | 2,944 | 2,789 | 2,650 | 2,524 | 2,409 | 2,304 | 2,208 |
| | 54 | 4,500 | 4,154 | 3,857 | 3,600 | 3,375 | 3,176 | 3,— | 2,842 | 2,700 | 2,571 | 2,455 | 2,348 | 2,250 |
| | 55 | 4,583 | 4,231 | 3,929 | 3,667 | 3,438 | 3,235 | 3,056 | 2,895 | 2,750 | 2,619 | 2,500 | 2,391 | 2,292 |
| | 56 | 4,667 | 4,308 | 4,— | 3,733 | 3,500 | 3,294 | 3,111 | 2,947 | 2,800 | 2,667 | 2,545 | 2,435 | 2,333 |
| 57 | 4,750 | 4,385 | 4,071 | 3,800 | 3,563 | 3,353 | 3,167 | 3,— | 2,850 | 2,714 | 2,591 | 2,478 | 2,375 | |
| 58 | 4,833 | 4,462 | 4,143 | 3,867 | 3,625 | 3,412 | 3,222 | 3,053 | 2,900 | 2,762 | 2,636 | 2,522 | 2,417 | |
| 59 | 4,917 | 4,538 | 4,214 | 3,933 | 3,688 | 3,471 | 3,278 | 3,105 | 2,950 | 2,810 | 2,682 | 2,565 | 2,458 | |
| 60 | 5,— | 4,615 | 4,286 | 4,— | 3,750 | 3,529 | 3,333 | 3,158 | 3,— | 2,857 | 2,727 | 2,609 | 2,500 | |
| 61 | 5,083 | 4,692 | 4,357 | 4,067 | 3,813 | 3,588 | 3,389 | 3,211 | 3,050 | 2,905 | 2,773 | 2,652 | 2,542 | |
| 62 | 5,167 | 4,769 | 4,429 | 4,133 | 3,875 | 3,647 | 3,444 | 3,263 | 3,100 | 2,952 | 2,818 | 2,696 | 2,583 | |
| 63 | 5,250 | 4,846 | 4,500 | 4,200 | 3,938 | 3,708 | 3,500 | 3,316 | 3,150 | 3,— | 2,864 | 2,739 | 2,625 | |
| 64 | 5,333 | 4,923 | 4,571 | 4,267 | 4,— | 3,765 | 3,556 | 3,368 | 3,200 | 3,048 | 2,909 | 2,783 | 2,667 | |
| 65 | 5,417 | 5,— | 4,643 | 4,333 | 4,063 | 3,824 | 3,611 | 3,421 | 3,250 | 3,095 | 2,955 | 2,826 | 2,708 | |
| 66 | 5,500 | 5,077 | 4,714 | 4,400 | 4,125 | 3,882 | 3,667 | 3,474 | 3,300 | 3,143 | 3,— | 2,870 | 2,750 | |
| 67 | 5,583 | 5,154 | 4,786 | 4,467 | 4,188 | 3,941 | 3,722 | 3,526 | 3,350 | 3,190 | 3,045 | 2,913 | 2,792 | |
| 68 | 5,667 | 5,231 | 4,857 | 4,533 | 4,250 | 4,— | 3,778 | 3,579 | 3,400 | 3,238 | 3,091 | 2,957 | 2,833 | |
| 69 | 5,750 | 5,308 | 4,929 | 4,600 | 4,313 | 4,059 | 3,833 | 3,632 | 3,450 | 3,286 | 3,136 | 3,— | 2,875 | |
| 70 | 5,833 | 5,385 | 5,— | 4,667 | 4,375 | 4,118 | 3,889 | 3,684 | 3,500 | 3,333 | 3,182 | 3,043 | 2,917 | |

TS/TR TABLE OF INDICATORS (cont.)

| | | TOUCHES RECEIVED | | | | | | | | | | |
|---------------------------------|----|------------------|-------|-------|-------|-------|-------|-------|-------|-------|-------|-------|
| | | 25 | 26 | 27 | 28 | 29 | 30 | 31 | 32 | 33 | 34 | 35 |
| T O U C H E S | 37 | 1,480 | 1,423 | 1,370 | 1,321 | 1,276 | 1,233 | 1,194 | 1,156 | 1,121 | 1,088 | 1,057 |
| | 38 | 1,520 | 1,462 | 1,407 | 1,357 | 1,310 | 1,267 | 1,228 | 1,188 | 1,152 | 1,118 | 1,086 |
| | 39 | 1,560 | 1,500 | 1,444 | 1,393 | 1,345 | 1,300 | 1,258 | 1,219 | 1,182 | 1,147 | 1,114 |
| | 40 | 1,600 | 1,538 | 1,481 | 1,429 | 1,379 | 1,333 | 1,290 | 1,250 | 1,212 | 1,176 | 1,143 |
| | 41 | 1,640 | 1,577 | 1,519 | 1,464 | 1,414 | 1,367 | 1,323 | 1,281 | 1,242 | 1,206 | 1,171 |
| | 42 | 1,680 | 1,615 | 1,556 | 1,500 | 1,448 | 1,400 | 1,355 | 1,313 | 1,273 | 1,235 | 1,200 |
| | 43 | 1,720 | 1,654 | 1,593 | 1,536 | 1,483 | 1,433 | 1,387 | 1,344 | 1,303 | 1,265 | 1,229 |
| | 44 | 1,760 | 1,692 | 1,630 | 1,571 | 1,517 | 1,467 | 1,419 | 1,375 | 1,333 | 1,294 | 1,257 |
| | 45 | 1,800 | 1,731 | 1,667 | 1,607 | 1,552 | 1,500 | 1,452 | 1,407 | 1,364 | 1,324 | 1,286 |
| | 46 | 1,840 | 1,769 | 1,704 | 1,643 | 1,586 | 1,533 | 1,484 | 1,408 | 1,394 | 1,353 | 1,314 |
| S C O R E D | 47 | 1,880 | 1,808 | 1,741 | 1,679 | 1,621 | 1,567 | 1,516 | 1,469 | 1,424 | 1,382 | 1,343 |
| | 48 | 1,920 | 1,846 | 1,778 | 1,714 | 1,655 | 1,600 | 1,548 | 1,500 | 1,455 | 1,412 | 1,371 |
| | 49 | 1,960 | 1,885 | 1,815 | 1,750 | 1,690 | 1,633 | 1,581 | 1,531 | 1,485 | 1,441 | 1,400 |
| | 50 | 2,— | 1,923 | 1,852 | 1,786 | 1,724 | 1,667 | 1,613 | 1,563 | 1,515 | 1,471 | 1,429 |
| | 51 | 2,040 | 1,962 | 1,889 | 1,821 | 1,759 | 1,700 | 1,645 | 1,594 | 1,545 | 1,500 | 1,457 |
| | 52 | 2,080 | 2,— | 1,926 | 1,857 | 1,793 | 1,733 | 1,677 | 1,625 | 1,576 | 1,529 | 1,486 |
| | 53 | 2,120 | 2,038 | 1,963 | 1,893 | 1,828 | 1,767 | 1,710 | 1,656 | 1,606 | 1,559 | 1,514 |
| | 54 | 2,160 | 2,077 | 2,— | 1,929 | 1,862 | 1,800 | 1,742 | 1,688 | 1,636 | 1,588 | 1,543 |
| | 55 | 2,200 | 2,115 | 2,037 | 1,964 | 1,896 | 1,833 | 1,774 | 1,719 | 1,667 | 1,618 | 1,571 |
| | 56 | 2,240 | 2,154 | 2,074 | 2,— | 1,931 | 1,867 | 1,806 | 1,750 | 1,697 | 1,647 | 1,600 |
| S C O R E D | 57 | 2,280 | 2,192 | 2,111 | 2,036 | 1,966 | 1,900 | 1,839 | 1,781 | 1,727 | 1,676 | 1,629 |
| | 58 | 2,320 | 2,231 | 2,148 | 2,071 | 2,— | 1,933 | 1,871 | 1,813 | 1,758 | 1,706 | 1,657 |
| | 59 | 2,360 | 2,269 | 2,185 | 2,107 | 2,034 | 1,967 | 1,903 | 1,844 | 1,788 | 1,735 | 1,686 |
| | 60 | 2,400 | 2,308 | 2,222 | 2,143 | 2,069 | 2,— | 1,935 | 1,875 | 1,818 | 1,765 | 1,714 |
| | 61 | 2,440 | 2,346 | 2,259 | 2,179 | 2,103 | 2,033 | 1,968 | 1,906 | 1,848 | 1,794 | 1,743 |
| | 62 | 2,480 | 2,385 | 2,296 | 2,214 | 2,138 | 2,067 | 2,— | 1,938 | 1,879 | 1,824 | 1,771 |
| | 63 | 2,520 | 2,423 | 2,333 | 2,250 | 2,172 | 2,100 | 2,032 | 1,969 | 1,909 | 1,853 | 1,800 |
| | 64 | 2,560 | 2,462 | 2,370 | 2,286 | 2,207 | 2,133 | 2,065 | 2,— | 1,939 | 1,882 | 1,829 |
| | 65 | 2,600 | 2,500 | 2,407 | 2,321 | 2,241 | 2,167 | 2,097 | 2,031 | 1,970 | 1,912 | 1,857 |
| | 66 | 2,640 | 2,538 | 2,444 | 2,357 | 2,276 | 2,200 | 2,129 | 2,063 | 2,— | 1,941 | 1,886 |
| | 67 | 2,680 | 2,577 | 2,481 | 2,393 | 2,310 | 2,233 | 2,161 | 2,094 | 2,030 | 1,971 | 1,914 |
| | 68 | 2,720 | 2,615 | 2,519 | 2,429 | 2,345 | 2,267 | 2,194 | 2,125 | 2,061 | 2,— | 1,943 |
| | 69 | 2,760 | 2,654 | 2,556 | 2,464 | 2,379 | 2,300 | 2,228 | 2,158 | 2,091 | 2,029 | 1,971 |
| | 70 | 2,800 | 2,692 | 2,593 | 2,500 | 2,414 | 2,333 | 2,258 | 2,188 | 2,121 | 2,059 | 2,— |

TS/TR TABLE OF INDICATORS (cont.)

| | | TOUCHES RECEIVED | | | | | | | | | | |
|---------------------------------|----|------------------|-------|-------|-------|-------|-------|-------|-------|-------|-------|-------|
| | | 36 | 37 | 38 | 39 | 40 | 41 | 42 | 43 | 44 | 45 | 46 |
| T O U C H E S | 37 | 1,028 | 1 | 0,974 | 0,949 | 0,925 | 0,902 | 0,881 | 0,860 | 0,841 | 0,822 | 0,804 |
| | 38 | 1,056 | 1,027 | 1 | 0,974 | 0,950 | 0,927 | 0,905 | 0,884 | 0,864 | 0,844 | 0,826 |
| | 39 | 1,083 | 1,054 | 1,026 | 1 | 0,975 | 0,951 | 0,929 | 0,907 | 0,886 | 0,867 | 0,848 |
| | 40 | 1,111 | 1,081 | 1,053 | 1,026 | 1 | 0,976 | 0,952 | 0,930 | 0,909 | 0,889 | 0,870 |
| | 41 | 1,139 | 1,108 | 1,079 | 1,051 | 1,025 | 1 | 0,976 | 0,953 | 0,932 | 0,911 | 0,891 |
| | 42 | 1,167 | 1,135 | 1,105 | 1,077 | 1,050 | 1,024 | 1 | 0,977 | 0,955 | 0,933 | 0,913 |
| | 43 | 1,194 | 1,162 | 1,132 | 1,103 | 1,075 | 1,049 | 1,024 | 1 | 0,977 | 0,956 | 0,935 |
| | 44 | 1,222 | 1,189 | 1,158 | 1,128 | 1,100 | 1,073 | 1,048 | 1,023 | 1 | 0,978 | 0,957 |
| | 45 | 1,250 | 1,216 | 1,184 | 1,154 | 1,125 | 1,098 | 1,071 | 1,047 | 1,023 | 1 | 0,978 |
| | 46 | 1,278 | 1,243 | 1,211 | 1,179 | 1,150 | 1,122 | 1,095 | 1,070 | 1,045 | 1,022 | 1 |
| S C O R E D | 47 | 1,306 | 1,270 | 1,237 | 1,205 | 1,175 | 1,146 | 1,119 | 1,093 | 1,068 | 1,044 | 1,022 |
| | 48 | 1,333 | 1,297 | 1,263 | 1,231 | 1,200 | 1,171 | 1,143 | 1,116 | 1,091 | 1,067 | 1,043 |
| | 49 | 1,361 | 1,324 | 1,289 | 1,256 | 1,225 | 1,195 | 1,167 | 1,140 | 1,114 | 1,089 | 1,065 |
| | 50 | 1,389 | 1,351 | 1,316 | 1,282 | 1,250 | 1,220 | 1,190 | 1,163 | 1,136 | 1,111 | 1,087 |
| | 51 | 1,417 | 1,378 | 1,342 | 1,308 | 1,275 | 1,244 | 1,214 | 1,186 | 1,159 | 1,133 | 1,109 |
| | 52 | 1,444 | 1,405 | 1,368 | 1,333 | 1,300 | 1,268 | 1,238 | 1,209 | 1,182 | 1,156 | 1,130 |
| | 53 | 1,472 | 1,432 | 1,395 | 1,359 | 1,325 | 1,293 | 1,262 | 1,233 | 1,205 | 1,178 | 1,152 |
| | 54 | 1,500 | 1,459 | 1,421 | 1,385 | 1,350 | 1,317 | 1,286 | 1,256 | 1,227 | 1,200 | 1,174 |
| | 55 | 1,528 | 1,486 | 1,447 | 1,410 | 1,375 | 1,341 | 1,310 | 1,279 | 1,250 | 1,222 | 1,196 |
| | 56 | 1,556 | 1,514 | 1,474 | 1,436 | 1,400 | 1,366 | 1,333 | 1,302 | 1,273 | 1,244 | 1,217 |
| S C O R E D | 57 | 1,583 | 1,541 | 1,500 | 1,462 | 1,425 | 1,390 | 1,357 | 1,326 | 1,295 | 1,267 | 1,239 |
| | 58 | 1,611 | 1,568 | 1,526 | 1,487 | 1,450 | 1,415 | 1,381 | 1,349 | 1,318 | 1,289 | 1,261 |
| | 59 | 1,639 | 1,595 | 1,553 | 1,513 | 1,475 | 1,439 | 1,405 | 1,372 | 1,341 | 1,311 | 1,283 |
| | 60 | 1,667 | 1,622 | 1,579 | 1,538 | 1,500 | 1,463 | 1,429 | 1,395 | 1,364 | 1,333 | 1,304 |
| | 61 | 1,694 | 1,649 | 1,605 | 1,564 | 1,525 | 1,488 | 1,452 | 1,419 | 1,386 | 1,356 | 1,326 |
| | 62 | 1,722 | 1,676 | 1,632 | 1,590 | 1,550 | 1,512 | 1,476 | 1,442 | 1,409 | 1,378 | 1,348 |
| | 63 | 1,750 | 1,703 | 1,658 | 1,615 | 1,575 | 1,537 | 1,500 | 1,465 | 1,432 | 1,400 | 1,370 |
| | 64 | 1,778 | 1,730 | 1,684 | 1,641 | 1,600 | 1,561 | 1,524 | 1,488 | 1,455 | 1,422 | 1,391 |
| | 65 | 1,806 | 1,757 | 1,711 | 1,667 | 1,625 | 1,585 | 1,548 | 1,512 | 1,477 | 1,444 | 1,413 |
| | 66 | 1,833 | 1,784 | 1,737 | 1,692 | 1,650 | 1,610 | 1,571 | 1,535 | 1,500 | 1,467 | 1,435 |
| | 67 | 1,861 | 1,811 | 1,763 | 1,718 | 1,675 | 1,634 | 1,595 | 1,558 | 1,523 | 1,489 | 1,457 |
| | 68 | 1,889 | 1,838 | 1,789 | 1,744 | 1,700 | 1,659 | 1,619 | 1,581 | 1,545 | 1,511 | 1,478 |
| | 69 | 1,917 | 1,865 | 1,816 | 1,769 | 1,725 | 1,683 | 1,643 | 1,605 | 1,568 | 1,533 | 1,500 |
| | 70 | 1,944 | 1,892 | 1,842 | 1,795 | 1,750 | 1,707 | 1,667 | 1,628 | 1,591 | 1,556 | 1,522 |

TS/TR TABLE OF INDICATORS (cont.)

| | | TOUCHES RECEIVED | | | | | | | | | | | |
|---------|-------|------------------|-------|-------|-------|-------|-------|-------|-------|-------|-------|-------|-------|
| | | 47 | 48 | 49 | 50 | 51 | 52 | 53 | 54 | 55 | 56 | 57 | 58 |
| TOUCHES | 37 | 0,787 | 0,771 | 0,755 | 0,740 | 0,725 | 0,712 | 0,698 | 0,685 | 0,673 | 0,661 | 0,649 | 0,638 |
| | 38 | 0,809 | 0,792 | 0,776 | 0,760 | 0,745 | 0,731 | 0,717 | 0,704 | 0,691 | 0,679 | 0,667 | 0,655 |
| | 39 | 0,830 | 0,813 | 0,796 | 0,780 | 0,765 | 0,750 | 0,736 | 0,722 | 0,709 | 0,696 | 0,684 | 0,672 |
| | 40 | 0,851 | 0,833 | 0,816 | 0,800 | 0,784 | 0,769 | 0,755 | 0,741 | 0,727 | 0,714 | 0,702 | 0,690 |
| | 41 | 0,872 | 0,854 | 0,837 | 0,820 | 0,804 | 0,788 | 0,774 | 0,759 | 0,745 | 0,732 | 0,719 | 0,707 |
| | 42 | 0,894 | 0,875 | 0,857 | 0,840 | 0,824 | 0,808 | 0,792 | 0,778 | 0,764 | 0,750 | 0,737 | 0,724 |
| | 43 | 0,915 | 0,896 | 0,878 | 0,860 | 0,843 | 0,827 | 0,811 | 0,796 | 0,782 | 0,768 | 0,754 | 0,741 |
| | 44 | 0,936 | 0,917 | 0,898 | 0,880 | 0,863 | 0,846 | 0,830 | 0,815 | 0,800 | 0,786 | 0,772 | 0,759 |
| | 45 | 0,957 | 0,938 | 0,918 | 0,900 | 0,882 | 0,865 | 0,849 | 0,833 | 0,818 | 0,804 | 0,789 | 0,776 |
| | 46 | 0,979 | 0,958 | 0,939 | 0,920 | 0,902 | 0,885 | 0,868 | 0,852 | 0,836 | 0,821 | 0,807 | 0,793 |
| 47 | 1 | 0,979 | 0,959 | 0,940 | 0,922 | 0,904 | 0,887 | 0,870 | 0,855 | 0,839 | 0,825 | 0,810 | |
| 48 | 1,021 | 1 | 0,980 | 0,960 | 0,941 | 0,923 | 0,906 | 0,889 | 0,873 | 0,857 | 0,842 | 0,828 | |
| 49 | 1,043 | 1,021 | 1 | 0,980 | 0,961 | 0,942 | 0,925 | 0,907 | 0,891 | 0,875 | 0,860 | 0,845 | |
| 50 | 1,064 | 1,042 | 1,020 | 1 | 0,980 | 0,962 | 0,943 | 0,926 | 0,909 | 0,893 | 0,877 | 0,862 | |
| 51 | 1,085 | 1,063 | 1,041 | 1,020 | 1 | 0,981 | 0,962 | 0,944 | 0,927 | 0,911 | 0,895 | 0,879 | |
| 52 | 1,106 | 1,083 | 1,061 | 1,040 | 1,020 | 1 | 0,981 | 0,963 | 0,945 | 0,929 | 0,912 | 0,897 | |
| 53 | 1,128 | 1,104 | 1,082 | 1,060 | 1,039 | 1,019 | 1 | 0,981 | 0,964 | 0,946 | 0,930 | 0,914 | |
| 54 | 1,149 | 1,125 | 1,102 | 1,080 | 1,059 | 1,038 | 1,019 | 1 | 0,982 | 0,964 | 0,947 | 0,931 | |
| 55 | 1,170 | 1,146 | 1,122 | 1,100 | 1,078 | 1,058 | 1,038 | 1,019 | 1 | 0,982 | 0,965 | 0,948 | |
| 56 | 1,191 | 1,167 | 1,143 | 1,120 | 1,098 | 1,077 | 1,057 | 1,037 | 1,018 | 1 | 0,982 | 0,966 | |
| 57 | 1,213 | 1,188 | 1,163 | 1,140 | 1,118 | 1,096 | 1,075 | 1,056 | 1,036 | 1,018 | 1 | 0,983 | |
| 58 | 1,234 | 1,208 | 1,184 | 1,160 | 1,137 | 1,115 | 1,094 | 1,074 | 1,055 | 1,036 | 1,018 | 1 | |
| 59 | 1,255 | 1,229 | 1,204 | 1,180 | 1,157 | 1,135 | 1,113 | 1,093 | 1,073 | 1,054 | 1,035 | 1,017 | |
| 60 | 1,277 | 1,250 | 1,224 | 1,200 | 1,176 | 1,154 | 1,132 | 1,111 | 1,091 | 1,071 | 1,053 | 1,034 | |
| 61 | 1,298 | 1,271 | 1,245 | 1,220 | 1,196 | 1,173 | 1,151 | 1,130 | 1,109 | 1,089 | 1,070 | 1,052 | |
| 62 | 1,319 | 1,292 | 1,265 | 1,240 | 1,216 | 1,192 | 1,170 | 1,148 | 1,127 | 1,107 | 1,088 | 1,069 | |
| 63 | 1,340 | 1,313 | 1,286 | 1,260 | 1,235 | 1,212 | 1,189 | 1,167 | 1,145 | 1,125 | 1,105 | 1,086 | |
| 64 | 1,362 | 1,333 | 1,306 | 1,280 | 1,255 | 1,231 | 1,208 | 1,185 | 1,164 | 1,143 | 1,123 | 1,103 | |
| 65 | 1,383 | 1,354 | 1,327 | 1,300 | 1,275 | 1,250 | 1,226 | 1,204 | 1,182 | 1,161 | 1,140 | 1,121 | |
| 66 | 1,404 | 1,375 | 1,347 | 1,320 | 1,294 | 1,269 | 1,245 | 1,222 | 1,200 | 1,179 | 1,158 | 1,138 | |
| 67 | 1,426 | 1,396 | 1,367 | 1,340 | 1,314 | 1,288 | 1,264 | 1,241 | 1,218 | 1,196 | 1,175 | 1,155 | |
| 68 | 1,447 | 1,417 | 1,388 | 1,360 | 1,333 | 1,308 | 1,283 | 1,259 | 1,236 | 1,214 | 1,193 | 1,172 | |
| 69 | 1,468 | 1,438 | 1,408 | 1,380 | 1,353 | 1,327 | 1,302 | 1,278 | 1,255 | 1,232 | 1,211 | 1,190 | |
| 70 | 1,489 | 1,458 | 1,429 | 1,400 | 1,373 | 1,348 | 1,321 | 1,296 | 1,273 | 1,250 | 1,228 | 1,207 | |

TS/TR TABLE OF INDICATORS (cont.)

| | | TOUCHES RECEIVED | | | | | | | | | | | |
|---------|-------|------------------|-------|-------|-------|-------|-------|-------|-------|-------|-------|-------|-------|
| | | 59 | 60 | 61 | 62 | 63 | 64 | 65 | 66 | 67 | 68 | 69 | 70 |
| TOUCHES | 37 | 0,627 | 0,617 | 0,607 | 0,597 | 0,587 | 0,578 | 0,569 | 0,561 | 0,552 | 0,544 | 0,536 | 0,529 |
| | 38 | 0,644 | 0,633 | 0,623 | 0,613 | 0,603 | 0,594 | 0,585 | 0,576 | 0,567 | 0,559 | 0,551 | 0,543 |
| | 39 | 0,661 | 0,650 | 0,639 | 0,629 | 0,619 | 0,609 | 0,600 | 0,591 | 0,582 | 0,574 | 0,565 | 0,557 |
| | 40 | 0,678 | 0,667 | 0,656 | 0,645 | 0,635 | 0,625 | 0,615 | 0,606 | 0,597 | 0,588 | 0,580 | 0,571 |
| | 41 | 0,695 | 0,683 | 0,672 | 0,661 | 0,651 | 0,641 | 0,631 | 0,621 | 0,612 | 0,603 | 0,594 | 0,586 |
| | 42 | 0,712 | 0,700 | 0,689 | 0,677 | 0,667 | 0,656 | 0,646 | 0,636 | 0,627 | 0,618 | 0,609 | 0,600 |
| | 43 | 0,729 | 0,717 | 0,705 | 0,694 | 0,683 | 0,672 | 0,662 | 0,652 | 0,642 | 0,632 | 0,623 | 0,614 |
| | 44 | 0,746 | 0,733 | 0,721 | 0,710 | 0,698 | 0,688 | 0,677 | 0,667 | 0,657 | 0,647 | 0,638 | 0,629 |
| | 45 | 0,763 | 0,750 | 0,738 | 0,728 | 0,714 | 0,703 | 0,692 | 0,682 | 0,672 | 0,662 | 0,652 | 0,643 |
| | 46 | 0,780 | 0,767 | 0,754 | 0,742 | 0,730 | 0,719 | 0,708 | 0,697 | 0,687 | 0,676 | 0,667 | 0,657 |
| 47 | 0,797 | 0,783 | 0,770 | 0,758 | 0,746 | 0,734 | 0,723 | 0,712 | 0,701 | 0,691 | 0,681 | 0,671 | |
| 48 | 0,814 | 0,800 | 0,787 | 0,774 | 0,762 | 0,750 | 0,738 | 0,727 | 0,716 | 0,706 | 0,696 | 0,686 | |
| 49 | 0,831 | 0,817 | 0,803 | 0,790 | 0,778 | 0,766 | 0,754 | 0,742 | 0,731 | 0,721 | 0,710 | 0,700 | |
| 50 | 0,847 | 0,833 | 0,820 | 0,806 | 0,794 | 0,781 | 0,769 | 0,758 | 0,746 | 0,735 | 0,725 | 0,714 | |
| 51 | 0,864 | 0,850 | 0,836 | 0,823 | 0,810 | 0,797 | 0,785 | 0,773 | 0,761 | 0,750 | 0,739 | 0,729 | |
| 52 | 0,881 | 0,867 | 0,852 | 0,839 | 0,825 | 0,813 | 0,800 | 0,788 | 0,776 | 0,765 | 0,754 | 0,743 | |
| 53 | 0,898 | 0,883 | 0,869 | 0,855 | 0,841 | 0,828 | 0,815 | 0,803 | 0,791 | 0,779 | 0,768 | 0,757 | |
| 54 | 0,915 | 0,900 | 0,885 | 0,871 | 0,857 | 0,844 | 0,831 | 0,818 | 0,806 | 0,794 | 0,783 | 0,771 | |
| 55 | 0,932 | 0,917 | 0,902 | 0,887 | 0,873 | 0,859 | 0,846 | 0,833 | 0,821 | 0,809 | 0,797 | 0,786 | |
| 56 | 0,949 | 0,933 | 0,918 | 0,903 | 0,889 | 0,875 | 0,862 | 0,848 | 0,836 | 0,824 | 0,812 | 0,800 | |
| 57 | 0,966 | 0,950 | 0,934 | 0,919 | 0,905 | 0,891 | 0,877 | 0,864 | 0,851 | 0,838 | 0,826 | 0,814 | |
| 58 | 0,983 | 0,967 | 0,951 | 0,935 | 0,921 | 0,906 | 0,892 | 0,879 | 0,866 | 0,853 | 0,841 | 0,829 | |
| 59 | 1 | 0,983 | 0,967 | 0,952 | 0,937 | 0,922 | 0,908 | 0,894 | 0,881 | 0,868 | 0,855 | 0,843 | |
| 60 | 1,017 | 1 | 0,984 | 0,968 | 0,952 | 0,938 | 0,923 | 0,909 | 0,896 | 0,882 | 0,870 | 0,857 | |
| 61 | 1,034 | 1,017 | 1 | 0,984 | 0,968 | 0,953 | 0,938 | 0,924 | 0,910 | 0,897 | 0,884 | 0,871 | |
| 62 | 1,051 | 1,033 | 1,016 | 1 | 0,984 | 0,969 | 0,954 | 0,939 | 0,925 | 0,912 | 0,899 | 0,886 | |
| 63 | 1,068 | 1,050 | 1,033 | 1,016 | 1 | 0,984 | 0,969 | 0,955 | 0,940 | 0,926 | 0,913 | 0,900 | |
| 64 | 1,085 | 1,067 | 1,049 | 1,032 | 1,016 | 1 | 0,985 | 0,970 | 0,955 | 0,941 | 0,928 | 0,914 | |
| 65 | 1,102 | 1,083 | 1,066 | 1,048 | 1,032 | 1,016 | 1 | 0,985 | 0,970 | 0,956 | 0,942 | 0,929 | |
| 66 | 1,119 | 1,100 | 1,082 | 1,065 | 1,048 | 1,031 | 1,015 | 1 | 0,985 | 0,971 | 0,957 | 0,943 | |
| 67 | 1,136 | 1,117 | 1,098 | 1,081 | 1,063 | 1,047 | 1,031 | 1,015 | 1 | 0,985 | 0,971 | 0,957 | |
| 68 | 1,153 | 1,133 | 1,115 | 1,097 | 1,079 | 1,063 | 1,046 | 1,030 | 1,015 | 1 | 0,986 | 0,971 | |
| 69 | 1,169 | 1,150 | 1,131 | 1,113 | 1,095 | 1,078 | 1,062 | 1,045 | 1,030 | 1,015 | 1 | 0,986 | |
| 70 | 1,186 | 1,167 | 1,148 | 1,129 | 1,111 | 1,094 | 1,077 | 1,061 | 1,045 | 1,029 | 1,014 | 1 | |

CHAPTER VII—TEAM COMPETITIONS

§ 1. Formulas for organization

564 Team competitions are fenced in such a fashion that each member of a team meets all the fencers of the opposing team, according to a predetermined order (see 566).

For the composition of pools of teams (see 6), the Directoire Technique will establish seedings by assembling all the information available permitting estimates of the respective strength of the teams (see 574f).

§ 2. Composition of teams

565 At the official FIE competitions, teams are composed of four or five members from among whom four are designated by the team captain for each team match.

The captain of each team may, for each team match, select the order in which his team members are entered on the score sheet.

A team may not begin a match if fewer than four fencers are present and ready to fence. However, a team may finish, with fewer than four fencers, a match already started.

As an exception, if, as a result of accidents or by reason of some cause outside their control and duly recognized, a team finds itself with fewer than four members, the Directoire Technique or the Organizing Committee may authorize one or more fencers properly entered, even for a different weapon, to complete the team.

§ 3. Order of bouts in a team match

566 The members of the two teams will fence each other in the following order:

| | | | |
|-----|-----|-----|-----|
| 3-8 | 6-3 | 1-6 | 5-1 |
| 4-6 | 8-1 | 3-5 | 6-2 |
| 1-7 | 5-4 | 2-8 | 7-3 |
| 2-5 | 7-2 | 4-7 | 8-4 |

§ 4. Classification [standing] of teams

The classification of teams will be determined in the following manner:

a) Match between two teams

567 The winning team is the one the members of which have won the greater number of individual victories.

In case of a tie in individual victories, the winning team will be the one that has received the smaller total number of touches; if there is an equality of individual victories and touches received, the match is a draw.

Each victory of one team over another is worth two match points.

Each drawn team match is worth one match point for each team.

Each defeat is worth zero match points.

b) Classification of several teams in the same pool

568 The general classification is determined by adding up the match points, the winning team being that which has the greatest number of points, and so on for the other places.

In case of a tie in match points between two or more teams in the same

pool, the classification is determined between them by adding up the total number of individual victories scored by each team's members during the whole pool.

In case of a tie in individual victories, the winning team is that one the members of which have collectively received the lowest number of touches in the course of the pool.

Finally, in case of a tie in touches received, the winning team is that one the members of which have collectively scored the greatest number of touches in the course of the pool.

If the number of match points, individual victories, touches received and touches scored are all identical for two or more teams, these teams will be classed as tied ["ex-aequo"].

If it is essential to distinguish the classification of these teams, there will be only one bout as the fence-off, fenced to a conclusion, and held immediately following the original competition, between fencers designated by each team captain from among those who have just taken part in the pool of teams.

As a consequence, it is obvious that, even when a team has a match won before all its fencers have met all their opponents, it is essential that all the remaining bouts be fenced, with the same attention and the same whole-hearted effort (see 607).

When the classification of a pool has been conclusively determined, the Directoire Technique is authorized to cancel the team matches (or even the bouts) still to be fenced, and accordingly halt the pool with the result established.

c) Withdrawal of a team member during a match

569 When one of the members of a team withdraws in the course of a match—without prejudice to possible later disciplinary penalties—his results up to the time he withdrew are counted, but all the subsequent bouts he would have fenced are to be entered as defeats, i.e., all such subsequent opponents are considered as having defeated him without having received a single touch from him.

However, when a team member is "obliged" to withdraw in the course of a match, as the result of an accident or as the result of circumstances beyond his control, duly recognized by the Director, his team captain may ask the Directoire Technique or, in their absence, the Organizing Committee, to authorize a substitute to continue the match from the point where the team member who was obliged to withdraw did so, even if this was in the course of a bout in progress.

However, a fencer thus replaced may not take his place on the team again in the same team match, nor in the next team match on the same day.

d) A team not completing a competition

570 I.—When, for whatever reason, a team does not finish a competition that it has begun, the Directoire Technique follows the rules laid down for the case of a competitor who does not finish a competition for individuals, each team being considered collectively as one competitor (see Article 532ff).

II.—When a team is scratched before a team match, it will be regarded:

1. as not finishing a competition that it has begun, if it has already fenced against another team in the pool (see 534ff).

2. as not having appeared in the competition at all, if this is its first match in the pool.

A. TEAM COMPETITIONS BY DIRECT ELIMINATION, INTEGRAL FORMULA

a) Principle

571 In the organization of team competitions by direct elimination, the rules applicable are the same as those for individual events, each team being considered as an individual competitor (see 549 to 555 and 563).

b) Formula for the team matches

572 Each team match will be fenced in such a fashion that each fencer on a team will meet all the fencers on the opposing team according to the bout order set forth in Article 566.

c) Fence-offs ["barrages"]

573 In case two teams finish completely tied (same number of individual victories and same total of touches), there will be one single fence-off bout, fenced to a conclusion, for which the fencers will be designated by the team captains from among those who have just fenced in that team match. The winning team will be that one whose fencer wins the fence-off bout.

B. TEAM COMPETITIONS BY MIXED FORMULA: POOLS AND DIRECT ELIMINATION

574 At the official FIE competitions, World Championships and Olympic Games, the team events will be fenced according to the formula of one round of pools, followed by a direct elimination table.

The rules below set forth:

—the method by which the pools of teams are to be assigned, by taking into account the results obtained in the individual competition by the fencers entered to fence in the team event.

—the method by which the direct elimination table is to be made up, by taking into account the results of the preliminary round of pools.

—the regulations for classification of the teams as the result of fencing the direct elimination table.

§ 1. Composition of the pools

575 The pools are made up by the Directoire Technique by taking into account, for the seedings, the classification earned by the fencers representing each nation in the individual competition; they shall consider, at a maximum, the results of the best 4 fencers from each nation, who are entered for the team event, using the following formula:

§ 2. Formula for quality points

576 Quality points are assigned as follows:

| | |
|---|-----------|
| To finalists | 6 points |
| To fencers eliminated in the semi-finals | 12 points |
| To fencers eliminated in the quarter-finals | 24 points |
| To fencers eliminated in the eighth-finals | 36 points |
| To fencers eliminated in the 1/16 finals | 48 points |
| To fencers eliminated in the 1/32 finals | 60 points |

The progression of 12 quality points per round is always to be observed for the earlier rounds.

Fencers who did not participate [in the individual event] will be rated at 4 points more than the highest figure to be derived from the number of rounds in that competition.

The team whose total of quality points is the lowest is ranked as No. 1, and the others follow in order corresponding to their totals of quality points.

The pools of teams are then assigned in the same way as for the individual events, the teams placed first in each pool thus becoming the first seeded teams, the teams placed second, the second seeded, and so on.

If the results of the pools confirm this classification, this same classification will be utilized by the Directoire Technique to place the qualified teams on the direct elimination table.

If the results of the pools do not confirm this seeding of the various teams, the Directoire Technique will change the classification that was made for assigning the pools by observing the following rules:

a) If, in a pool, the first seeded team loses its first place to another team and finishes second in the pool, it will take the highest second seeded place in the classification; the team winning in the pool will then take the last place among the first seeded teams in the classification.

b) If, in a pool, the second seeded team loses its second place rank to a third or fourth seeded team, the latter team then takes the last place among the second seeded teams in the classification.

c) These reclassifications of teams thus oblige the Directoire Technique to relocate in the classification, either higher or lower, those qualified teams whose results confirmed the original classification.

d) If the results of several pools should have the effect of changing the original classification of the teams, the Directoire Technique shall make the necessary reclassifications and relocations by observing the following order of priority of the pools:

- 1 — the results of pool A
- 2 — the results of pool B
- 3 — the results of pool C
- 4 — the results of pool D

Examples:

16 teams distributed as follows according to the establishment of the classification of differently seeded teams:

| | Pool A | Pool B | Pool C | Pool D |
|---------------------|--------|--------|--------|--------|
| First seeded teams | 1 | 2 | 3 | 4 |
| Second seeded teams | 8 | 7 | 6 | 5 |
| Third seeded teams | 9 | 10 | 11 | 12 |
| Fourth seeded teams | 16 | 15 | 14 | 13 |

1. In pool B team No. 7 wins the pool, and by this fact team No. 2 becomes second seeded, and the reclassification of the teams will be made in the following manner:

- The team ranked No. 7 becomes No. 4,
- The team ranked No. 2 becomes No. 5.
- The relocation of the other teams will be:
- The team ranked No. 3 is advanced to No. 2,
- The team ranked No. 4 is advanced to No. 3,
- The team ranked No. 5 is reduced to No. 6,
- The team ranked No. 6 is reduced to No. 7.

The teams ranked No. 1 and No. 8 do not change.

2. In pool C, team No. 11 wins the pool, and team No. 3 places second, and by this fact team No. 6 is eliminated; the reclassification of the teams will be made in the following manner:

The team ranked No. 11 becomes No. 4,
The team ranked No. 3 becomes No. 5.
The relocation of the other teams will be:
The team ranked No. 4 is advanced to No. 3,
The team ranked No. 5 is reduced to No. 6.

The teams ranked 1, 2, 7 and 8 do not change.

3. In pool D, team No. 12 places second in the pool, and by this fact team No. 5 is eliminated; the reclassification of the teams will be made thus:

The team ranked No. 12 becomes No. 8.
The relocation of the other teams will be:
The team ranked No. 8 is advanced to No. 7,
The team ranked No. 7 is advanced to No. 6,
The team ranked No. 6 is advanced to No. 5.

The teams ranked No. 1, 2, 3 and 4 do not change.

The preceding examples are based on changes in the results in only one pool, whether B, or C, or D.

However, if at the end of the round of pools the results of pool B and of pool C both call for changes, the Directoire Technique will make the necessary modifications in the original classification by first taking into account the results of pool B and then by applying to this new classification the results of pool C.

Example:

After the reclassifications and relocations required by the results of pool B, the classification of the teams is as follows:

| | | | | | | | | |
|---------------|---|---|---|---|---|---|---|----|
| Team No.: | 1 | 3 | 4 | 7 | 2 | 5 | 6 | 8. |
| Ranked order: | 1 | 2 | 3 | 4 | 5 | 6 | 7 | 8. |

However, after the reclassifications and relocations made as the results of the standings in pool C, the final classification of the teams will be as follows:

| | | | | | | | | |
|---------------|---|---|---|----|---|---|---|----|
| Team No.: | 1 | 4 | 7 | 11 | 2 | 3 | 5 | 8. |
| Ranked order: | 1 | 2 | 3 | 4 | 5 | 6 | 7 | 8. |

§ 3. Direct elimination table

577 Once the classification of the teams has been established according to the results of the round of pools, the Directoire Technique will place the qualified teams on the direct elimination table. However, under no circumstances may the two teams from the same pool meet again in the first round of direct elimination. In case the present rules do not permit the application of this regulation, the teams ranked as second in the pools will be exchanged: on the one hand, between the A and B quarters of the table, and on the other hand, between the C and D quarters of the table.

Supplementary team matches, in direct elimination, necessary to establish the direct elimination table, will always be regarded as the first round of direct elimination. As a result, for the team matches of the first round only, the exchange defined in the preceding paragraph will be made in order to avoid having the teams which have already met in the elimination pools meet again in the first round of direct elimination.

Direct Elimination Table for Teams

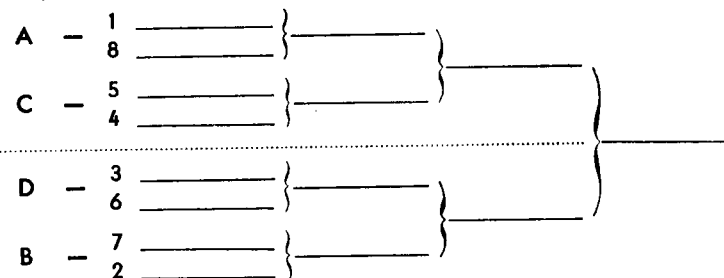

§ 4. Classification [final standing] for places after 1st and 2nd

578 A supplementary team match between the teams defeated in the semi-finals will be needed to award the third and fourth places. This match should be fenced before the match to determine first place.

In addition, in case of need, the fifth and sixth places will be determined as follows:

—the four teams defeated in the quarter final of the direct elimination table will meet in two matches of two, following the order of the table.
—the two winners of these two matches will then meet to determine fifth and sixth places.

These three matches will be fenced on a strip other than the strip where the semi-finals and finals are held, and in any case must be finished before the match to determine third place.

CHAPTER VIII—SPECIAL RULES FOR THE WORLD CHAMPIONSHIPS* HISTORICAL NOTE

A. INDIVIDUAL CHAMPIONSHIPS

§ 1. Annual championship

In accordance with decisions taken by the Congresses held in Anvers in 1920, at La Haye in 1927, at Amsterdam in 1928, at Brussels in 1937, at Anvers in 1939, at Brussels in 1947, and at Madrid in 1962, official individual championships in foil, epee, and sabre for men, and in foil for women, known as the "World Championships" (called European Championships until 1936), are held annually under the auspices of the FIE, in principle between July 1 and August 15.

The fencing events at the Olympic Games are conducted under the direction of the FIE and constitute the World Championships in the Olympic years.

* The original text of Chapter VIII, inserted in this technical rules book for information, appears in the Book of Statutes of the FIE. It is prepared by the Commission on Statutes. In case of errors or of differences between the texts, that of the Book of Statutes is authoritative.

§ 2. Bids ["candidatures"]

579 Each year bids or applications for holding the World Championships for the following year must be submitted to the Central Office of the FIE, for entry on the agenda of the annual Ordinary Congress, within the time limits set forth in the Statutes for entries on that agenda (see Book of Statutes).

The Congress will designate the national federation to which the organization of these championships will be entrusted the following year, and will set the date, and fix the place where they will be held.

In case the annual Ordinary Congress was unable, for lack of applications, to designate a federation to organize the championships, the Central Office of the FIE itself may designate a federation to organize them, if it receives one or more applications after the Congress.

The Central Office has the same powers in case the federation regularly designated by the Congress withdraws.

§ 3. Entries

580 Entries are limited to five fencers of the same nationality in each event (3 in the Olympic Games).

§ 4. Formula for the competitions

581 The individual championships will be held by pools, with the mixed formula of pools of 4, for which the rules are set forth in Articles 541 to 548 of the present rules book, as well as in Articles 119 to 128 of the Book of Statutes.

B. TEAM CHAMPIONSHIPS

§ 1. Simultaneity

582 The national federation to which the organization of the individual championships has been entrusted must also arrange to hold team championships, at the same time and place, in all three weapons for men, and in foil for women.*

§ 2. Entries

583 Entries are limited to one team in each weapon per country, each team to be composed of four or five fencers of the same nationality, of whom four are designated by the team captain for each of the team matches.

The names of the five team members will be announced on the eve of each event and may not thereafter be changed (see 565).

Countries that wish to enter a team in one or more of the World Championship events must so notify the national federation in charge of the organization a month and a half before the beginning of the competitions, and confirm to them, eight days before that same date, the number of teams on whose participation they may actually rely.

* The title of "champion" in team events may not be conferred unless there is a minimum of five teams participating in the men's events, and of four teams participating in the women's events.

The organizers must notify the Central Office of the FIE, at least one month before the championships, listing the countries that have announced their participation in each of the team events.

§ 3. Formula (see 574ff and Statutes 129 and 130).

584 The team events will be fenced with at least one round of pools followed by a direct elimination table.

The arrangement of the pools is made by the Directoire Technique by taking into account, for the selection of seeded teams, the classifications earned by the fencers representing each nation in the corresponding individual competition, according to the formula for quality points set forth in Article 576, but considering at a maximum the results of the 4 best fencers of each nation who are entered to fence in the team event.

Article 576 also sets forth what effects the results in the pools may have on the classification established by the Directoire Technique.

Articles 577 and 578 govern the establishment of the direct elimination table according to the results of the pools of teams, and the fashion in which the matches for determining classification must be held.

C. PROVISIONS COMMON TO ALL CHAMPIONSHIP EVENTS

§ 1. Participation

585 The World Championships are open to all national federations affiliated with the FIE.

§ 2. Entries

586 Countries that wish to send fencers to the World Championships, either for the individual or team events, must so notify the national federation in charge of the organization, a month and a half before the beginning of the events.

The teams of the federations that are entered in all eight events of the World Championships must be accompanied by two international Directors ["Presidents de jury"]; those entering fewer events, but with seven or more fencers, must be accompanied by one international Director. These Directors will be at the disposition of the Directoire Technique throughout the duration of the events.

Eight days before the beginning of the competitions, each participating federation must confirm to the organizers the number and the names of its participants in each event. Substitutions, due to reasons beyond a federation's control, may be made only up to the eve of the competitions.

§ 3. FIE Rules

587 Apart from the particular rules appearing in the present chapter, the rules of the FIE will be strictly observed for the events of the World Championships.

§ 4. Order of events

- 588** The competitions will be fenced in the following order:
- 1st day: Men's Foil, individual, elimination rounds.
 2nd day: Men's Foil, individual, continuation and final.
 Sabre, individual, elimination rounds.
 3rd day: Sabre, individual, continuation and final.
 4th day: Men's Foil, team, elimination rounds.
 5th day: Men's Foil, team, continued:
 determination of 5th and 6th places,
 match for 3rd and 4th places,
 final.
 Women's Foil, individual, elimination rounds.
 6th day: Women's Foil, individual, continuation and final.
 Sabre, team, elimination rounds.
 7th day: Sabre, team, continued:
 determination of 5th and 6th places,
 match for 3rd and 4th places,
 final.
 Epee, individual, elimination rounds.
 8th day: Epee, individual, continuation and final.
 9th day: Women's Foil, team, elimination rounds.
 10th day: Women's Foil, team, continued:
 determination of 5th and 6th places,
 match for 3rd and 4th places,
 final.
 Epee, team, elimination rounds.
 11th day: Epee, team, continued:
 determination of 5th and 6th places,
 match for 3rd and 4th places,
 final.

§ 5. Directoire Technique

589 The technical conduct of the championships is managed by a Directoire Technique of six members of different nationalities, including one representative of the organizing country.

At the Olympic Games, this number is increased to seven, of whom one represents the organizing country, one represents the countries of North America and one represents the countries of South America.

The President of the Directoire Technique is appointed by the Central Office of the FIE from among the members of the Directoire Technique.

§ 6. Supervision by the FIE

590 In order to ensure that the rules are observed, the President of the FIE, or the member of the Central Office of the FIE designated by the President, has the right to attend all meetings of the Directoire Technique, which must give them notice of all such meetings.

Furthermore, the Jury of Appeal, if it is summoned, is presided over ex officio by the President of the FIE, or by a delegate of the Central Office of the FIE (in their absence, see 507).

§ 7. Number of touches

591 The number of touches in all three weapons is the following:

In pools:

Women (foil): 4 effective touches

Men (all three weapons): 5 effective touches

In direct elimination:

Women (foil): two bouts for 4 effective touches with a deciding bout if necessary; or one bout for 8 effective touches.

Men (all three weapons): two bouts for 5 effective touches with a deciding bout if necessary; or one bout for 10 effective touches.

D. THE OLYMPIC GAMES

592 The rules for the World Championships are applicable to the Olympic Games, except on the points on which they are at variance with the Olympic Rules.*

CHAPTER IX—RULES FOR THE WORLD UNDER-20 CHAMPIONSHIPS**

§ 1. Frequency of the Championships

593 In accordance with decisions taken by the Congresses held at Paris in 1949 and 1951, at Venice in 1955, at Paris in 1959, at Madrid in 1962, and at Gdansk in 1963, World Under-20 Championships, comprising individual competitions in foil, epee, and sabre for men, and in foil for women, are held annually under the auspices of the FIE.

The supervision by the FIE is arranged under the same conditions as for the World Championships, as is the technical direction. The Directoire Technique is composed of 5 members (see 505).

§ 2. Bids ["candidatures"]

594 Each year, bids or applications for holding the World Under-20 Championships must be forwarded to the Central Office of the FIE to be entered on the agenda of the annual Ordinary Congress within the time limits set forth in the Statutes for entry on that agenda (see Statutes, Article 50).

The Congress will designate the national federation to which the organization of these Championships will be entrusted the following year, and will set the date, and fix the place where they will be held.

In principle, the World Under-20 Championships take place at Easter time.

In case of lack of applications, or of withdrawal of the federation charged with the organization, the same rules apply as for the World Championships (see 579).

* Entries to the Olympic Games, for the individual events, are limited to three fencers of the same nationality in each event, instead of five as at the World Championships. In addition, the total of entries for one nation may not exceed 20.

** The original text of Chapter IX, inserted here for information in this technical rules book, appears in the Book of Statutes of the FIE. It is prepared by the Commission on Statutes. In case of errors or of differences between the texts, that of the Book of Statutes is authoritative.

§ 3. Entries

595 Entries are limited to three fencers of the same nationality in each event.

Countries that wish to send fencers to these Championships must advise the federation charged with the organization one and a half months before the beginning of the competitions.

Eight days before the beginning, the number and the names of the participants from each country must be transmitted to the organizers. Substitutions, made by federations for reasons outside their control, may be made only up to the eve of each event.

§ 4. Age of participants

596 The participants must have been less than 20 years old on 1 January of the year in which the World Under-20 Championship is held; the Directoire Technique will verify participants' ages before the competition begins.

§ 5. Rules

597 The rules for the World Championship are applicable to the World Under-20 Championship.

However, the Directoire Technique will decide, according to the number of entries, whether the pools of 4 will begin with 24 fencers remaining or with 12.

598 The Directoire Technique for the World Under-20 Championships is composed of only 5 members of different nationalities, including one representative of the organizing country.

§ 6. Order of the events

599 The events will be fenced in the following order:

- 1st day: Men's Foil, elimination rounds
- 2nd day: Women's Foil, elimination rounds
Men's Foil, final.
- 3rd day: Epee, elimination rounds
Sabre, elimination rounds
Women's Foil, final.
- 4th day: Epee, semi-finals and final.
Sabre, semi-finals and final.

PART SIX: DISCIPLINARY CODE FOR COMPETITIONS

CHAPTER I – APPLICABILITY

§ 1. Persons subject to these rules

601 The regulations set forth in Part SIX apply to all persons who take part in or attend an international fencing competition in any capacity (as organizers, officials, members of juries, auxiliary personnel,

team captains, competitors, trainers, spectators, etc.), whether they are amateurs or not and whatever their nationality.

All these persons are meant by the term "fencers" in the Articles that follow.

§ 2. Order and discipline

602 Fencers must scrupulously and honestly observe the rules of the FIE, the particular rules of the competition in progress, the traditional customs of courtesy and integrity, and the orders of the officials.

They will in particular submit themselves, in an orderly, disciplined, and sportsmanlike fashion, to the regulations which follow, all infractions of which may entail punishments imposed by the competent disciplinary authorities, after or even without a warning, depending on the case and the circumstances.

§ 3. The competitors

a) Pledge of honor

603 By the mere fact of participating in a fencing competition, the competitors pledge their honor to obey the rules and abide by the decisions of the judges, to be respectful to the members of the jury, and to obey scrupulously the commands and instructions of the Director (see 657).

b) Appearance on time

604 The competitors, fully equipped conformably to the rules (see 21) and ready to fence, must present themselves at the time and place fixed for the beginning of each pool, team match, or direct elimination match, and likewise during the course of the competition at every call of the Director (see 654).

They must appear at the strip to fence their bouts with two regulation weapons (one a spare) in perfect working order (see 21 and 657).

c) Manner of fencing

605 The competitors will fence honestly and strictly according to the rules prescribed in the chapters treating the conventions of fencing in general (see 28) and of each weapon in particular (see 219, 316, 409); every infraction of these rules will entail the penalties set forth below (see 638ff, 648ff, and 654ff).

d) Acknowledging a touch

606 Every competitor is free to acknowledge aloud a touch received at the moment when he receives it. But the jury is not bound by this acknowledgement and may still deliberate on this touch (see 66f, 72ff).

On the other hand, it is absolutely forbidden for the competitors to make any gestures or remarks—except for the permissible acknowledgement of the touch—that could influence the decisions of the jury, or, after the Director's decision, to acknowledge a touch that has not been awarded (see 642, 655 and 657).

e) Defending one's own chances

607 The competitors will expend the same effort and give the same attention to every bout; they will defend their own personal interest in a sportsmanlike manner through to the end of the competition so as to earn the best possible placement, without giving touches to, or seeking touches from, anyone (see 653f).

§ 4. Doping

608 The use of substances intended to increase, in an artificial and transitory manner, one's physical and psychical capabilities in sporting activities is prohibited by the FIE.

Every violation of this rule entails disciplinary penalties.

a) Doping is the use or application in any form of products foreign to the organism and of organic products in abnormal doses, with the intent of improving performance in a dishonest fashion. (Definition established by the World Congress on Doping in Tokyo in 1964.)

Because of the grave danger that doping presents to the health of its practitioners, the President of the FIE, or any other person authorized by the FIE to do so, may require, at any competition organized under control of the FIE, the taking under medical supervision of samples for analysis of the solids, liquids or gases absorbed or excreted by FIE license holders.

b) The list of forbidden substances is revised by the Medical Commission of the FIE at its periodic meetings. This list is based on the regulations adopted by international athletic bodies such as the International Olympic Committee, the International Federation for Sports Medicine, etc.

This list is submitted for the approval of the FIE during its annual Congress and must be published before the beginning of competitions. It may not be changed during the course of competitions.

c) The licenses issued through the Federations affiliated with the FIE must carry the following notice:

"The holder of this license agrees not to practice doping and to submit to all inspections."

d) In case a fencer refuses to submit the samples required, the refusal will be put in writing, signed by him or her and forwarded to the body responsible for deciding the case.

In such a case, every fencer must be aware that he or she will be considered *a priori* as having used forbidden substances.

e) Every organizer of competitions must provide such an arrangement for inspections. The costs of the anti-doping testing will be borne by the organizing association or federation.

f) An athlete is considered as doped when a forbidden substance or one of its characteristic byproducts can be objectively revealed by biological analyses performed and checked by experts.

g) Upon the strength of the result of an analysis proving the use of a forbidden substance, the association or federation organizing the competition must set in motion a procedure for imposing a penalty through the FIE which will decide on the disciplinary sanctions to be taken.

h) The method of selecting competitors for anti-doping testing will be fixed in advance, at the beginning of each competition, by the Medical Commission of the FIE, in agreement with the President of the FIE, and must not be divulged to the participating federations.

In principle, the tests will be performed, on the one hand, on the two or three highest placed competitors, and on the other hand, on one, or several, chosen by lot from those in lower classifications.

For team competitions, the tests will be performed either on the whole team, or on some one or more of the fencers on the team chosen by lot.

In addition, the physicians in charge have the right to examine any athlete suspected of doping; however, this decision may not be taken by the mem-

bers of the FIE Medical Commission (with a minimum of three acting) until after they have advised the President of the FIE of their intent.

i) Fencers and non-medical trainers are forbidden to carry or possess substances used for doping at the site of competitions. In principle, no attention is paid to denunciations.

j) Treatments that may have been administered within the 72 hours preceding the beginning of the competition must be brought to the attention of the physician in charge by means of an official form.

Anesthesia performed by a physician in case of injury is permitted.

k) The results of the tests are strictly confidential. Neither the physicians in charge, nor the laboratory personnel making the analyses, are authorized to give out information, particularly to the press.

l) If the result of an analysis is positive, the laboratory chief immediately informs the President of the FIE Medical Commission, through the person responsible for the testing, and communicates the details of the analysis within 48 hours.

The President of the Medical Commission immediately calls it together and also invites to the meeting the physician responsible for the fencer concerned, or another physician named by the delegation concerned. The President of the Medical Commission is required to transmit the report of the analysis to the President of the FIE and to the fencer concerned.

m) The fencer, within the following 12 hours, may request in writing that the President of the Medical Commission have a verification made of the results of the test by means of the second sample. (See the Administrative Rules of the FIE.)

This test is to be made in the same laboratory; however, the personnel performing the analysis will not be the same. The test will be carried out under the observation of one of the members of the Medical Commission. The federation concerned is also authorized to send an observer, if possible a qualified one, to witness this test.

n) In case the result is positive, the cost of the tests is to be charged to the fencer or the federation concerned.

o) The member of the Medical Commission transmits the result of the second analysis to the President of that Commission. The latter informs the President of the FIE, whose responsibility it is to summon the disciplinary commission and make an official announcement.

Penalties

The penalties which are to be imposed on fencers whose practice of doping has been proved are the following:

a) For a first offense

—exclusion from the competition, i.e., from all events of the championships in progress.

—loss, if applicable, of any title won by the fencer and by his team if the latter has profited from the doping.

—regular submission to anti-doping tests in subsequent competitions.

b) For a second offense

—disqualification from all international competitions until the close of the analogous competition the following year.

c) For a third offense

—revocation for life of the fencer's international license.

The publication of the decisions reached will be made by the Executive Committee of the FIE, which alone has the right to bring them to the

attention of the federation of the fencer concerned.

The Articles concerning the procedures for taking samples and for the analysis of these samples are appended to the Administrative Rules in the Book of Statutes of the FIE. The list of forbidden products appears each year in the Minutes of the Ordinary Congress of the FIE.

§ 5. The team captain

609 In each international competition, the competitors of the same nationality are directed by a team captain (who may or may not fence), who is responsible to the Directoire Technique or to the Organizing Committee for the discipline, conduct, and sportsmanship of the fencers on his team.

The team captain alone has the right to approach the Directoire Technique, or the Organizing Committee, or the juries, etc., to take up with them all questions concerning technical matters, protests, or observations.

Team members who abide strictly by his instructions cannot be held responsible for them before the competent authorities. However, they will remain personally liable for all acts that they commit apart from the intervention of their captain and for all offenses that they commit in violation of the provisions of the present rules.

§ 6. The members of the jury

610 The members of the jury must carry out their functions not only with complete impartiality, but also with the most scrupulous attention (see 652).

The Directoire Technique (or the Organizing Committee), has the power to replace immediately a Director or a member of the jury, even if they are convinced of his perfect good faith, whenever they believe that such replacement is necessary either for technical reasons or to maintain the good order of the competition.

§ 7. Coaches, trainers and technicians

611 Coaches, trainers and technicians (whether amateurs or not) may be permitted to station themselves in the course of a competition near their teams or individual fencers. They are, however, required to confine themselves strictly to their functions, without any sort of interference in the progress of the competition. They may not go onto the strip to offer medical or technical assistance to a fencer without the permission of the Director (see 656).

§ 8. The spectators

612 Spectators are obliged not to interfere with the good order of the competition, to do nothing that might tend to influence the fencers or the jury, and to respect the decisions of the jury even when they do not approve of them. They must obey any instructions that the Director may deem it necessary to give them (see 656).

CHAPTER II — THE DISCIPLINARY AUTHORITIES AND THEIR COMPETENCE

§ 1. Bodies having jurisdiction

613 The good order and discipline of fencing competitions, in varying degrees, rest with the following persons or bodies:

- the Director [President of the Jury] (see 615);
- the Organizing Committee (see 503, 616);
- the Directoire Technique (see 505, 617);
- the Jury of Appeal (see 506ff, 618);
- The Executive Committee of the International Olympic Committee at the Olympic Games (see 505, 510, 619);
- the National Federation (see 620);
- The Central Office of the FIE (see 504, 590, 621);
- the Executive Committee of the FIE;
- the Congress of the FIE (see 622).

§ 2. Principle of jurisdiction

614 a) Whatever authority has taken a decision, that decision is susceptible to an eventual appeal to a higher jurisdiction, but to one appeal only.

b) Every decision made on an appeal, however, allows the appellant the right of an ultimate appeal to the Congress of the FIE (when it concerns an official FIE competition), or to the Central Office of the FIE (for any other international competition).

c) No decision on a matter of fact can be appealed.

d) An appeal against a decision does not suspend [stay] that decision unless the appeal can be heard without delay. An ultimate appeal does not suspend a decision, except when the authority which reached the decision agrees to a suspension.

e) Every appeal must be accompanied by the deposit of a guaranty of one hundred French francs, or its equivalent in other currency, and every ultimate appeal by the deposit of a guaranty of two hundred French francs or its equivalent in other currency; these sums may be confiscated in whole or in part for the benefit of the FIE in case the appeal is rejected as "frivolous"; this decision will be taken by the authority which pronounces on the appeal. However, appeals against the decision of a Director do not require the deposits mentioned above (see 511, 659f).

§ 3. The Director [President of the Jury]

615 a) The Director is responsible not only for the direction of the bout, the judging of touches and the inspection of equipment, but also for the maintenance of order in the competitions over which he presides (see 53).

b) As director of combat and judge of the touches, he can, in accordance with the rules, penalize the fencers: either by refusing to award a touch actually made against the opponent, or by awarding against a fencer a touch not actually received, or by excluding a fencer from the competition over which he is presiding—all, according to circumstances, after or without prior warning. In such cases, if he has decided on a matter of fact, his decisions are irrevocable (see 659).

All warnings and all penalties must be noted on the score sheet of the pool, and reported by the Directoire Technique on the score sheets of pools in which the fencer penalized subsequently participates.

c) By virtue of the jurisdiction that he has over all the fencers participating in or attending the competition over which he is presiding, he may likewise order the expulsion from the site of the competition of spectators, trainers, coaches, and others who accompany the competitors (see 656).

d) Finally, he may recommend to the Directoire Technique (or in its absence to the Organizing Committee) all other penalties that he believes are deserved (exclusion from the whole competition, suspension, or disqualification (see 617)).

e) The Directoire Technique (or in its absence the Organizing Committee) is the body competent to hear appeals against decisions of a Director (see 616f, 659).

§ 4. The Organizing Committee

(See 503).

616 In disciplinary matters, the Organizing Committee is competent to act only when there is no Directoire Technique, whose functions it is fulfilling; in this case it must meet all the obligations incumbent on the Directoire Technique (see 617).

§ 5. The Directoire Technique

(See 505).

617 a) The Directoire Technique has jurisdiction over all the fencers who take part in or attend the competition that it is directing.

In case of necessity, it can intervene on its own initiative in all disputes. It may pronounce, either on its own initiative or at the recommendation of a Director, all applicable penalties in the course of a competition.

b) It constitutes the jurisdiction to hear appeals against decisions of the Directors. In this case, however, if it is not international (see 505), it must add to its membership one representative of each country participating in the competition.

c) Decisions of the Directoire Technique are subject to appeal to the Jury of Appeal (see 506ff, 618), except, however, those decisions which it has itself reached on appeals, which can be subject only to an ultimate appeal (see 614).

d) The Directoire Technique itself is obliged, should the occasion arise, to notify the Jury of Appeal of complaints, protests, or requests for appeal that are submitted to it in the prescribed forms.

e) In addition, it forwards directly to the Central Office of the FIE, requests for suspension, for extension of a penalty, and for permanent suspension or disqualification, as well as any ultimate appeals.

f) The Directoire Technique carries out all penalties pronounced finally or not subject to suspension (see 614).

§ 6. The Jury of Appeal

(See 506.)

618 a) The Jury of Appeal must be convened immediately by the Directoire Technique (or when necessary by the Organizing Com-

mittee), either on its own initiative, or at the request of a team captain, an official delegate of the federation concerned, a Director, or a delegate of the Central Office of the FIE (see 590).

b) Decisions of the Jury of Appeal, since they are always made on an appeal, are subject only to ultimate appeal to the Central Office or the Congress of the FIE (see 614).

§ 7. The Executive Committee of the International Olympic Committee at the Olympic Games

619 The Executive Committee of the International Olympic Committee decides, as the court of last resort, all disputes of a non-technical nature that arise during the Olympic Games. It may intervene either on its own responsibility, or at the request of a National Olympic Committee, of the FIE, or of the Organizing Committee (see Article 39 of the General Rules for the Olympic Games, 1971 edition) (see 505, 510).

§ 8. The National Federation

620 a) The national federation is the competent authority for all fencing activities organized within its territory; it has jurisdiction, through its regular disciplinary bodies, over all fencers who reside, even transiently, within its territory.

b) It may impose all applicable penalties within the limits of its territory.

c) It may recommend to the Central Office of the FIE the extension outside of its territory of penalties it has imposed.

d) It rules on complaints addressed to it through the regular channels; it has the right to bring up directly, at whatever stage of the affair, the question of any offense described herein that has been committed within its territory.

e) When the case involves a foreign fencer who is not normally under its jurisdiction, the national federation may not impose the penalty until it has received advice from the national federation to which the fencer concerned normally belongs. The latter national federation must render its opinion within one month, normal transmittal time excluded. If the opinion has not been given at the expiration of this time, the penalty is imposed. In case of disagreement between the two federations, the complete file on the affair is forwarded to the Central Office of the FIE.

§ 9. The Central Office of the FIE

(See 504, 590).

621 a) The Central Office of the FIE, within the limits of the territories under the jurisdiction of the FIE, is competent to deal with all affairs which are referred to it by a national federation, a Jury of Appeal, or a Directoire Technique at an international tournament.

b) In particular it is the body responsible for judging all ultimate appeals against decisions made on appeals that arise in the course of international competitions other than the official FIE competitions.

c) The Central Office of the FIE may impose all the prescribed penalties; it may confirm, increase, or annul penalties imposed by lesser authorities.

§ 10. The Congress of the FIE

622 The Congress of the FIE has the same rights as the Central Office, but particularly over matters that concern the official FIE competitions (see 614).

CHAPTER III – PENALTIES

§ 1. Classes of penalties

623 There are two distinct classes of penalties applicable to the two categories of offenses (see 635ff).

1. Fencing penalties which are applicable to offenses committed in fencing, and which are:

- the loss of ground;
- refusal to award a touch actually made;
- award of a touch not actually received;
- exclusion from the competition.

2. Disciplinary penalties, which are applicable to offenses committed against good order, discipline, or sportsmanship, and which are:

- award of a touch not actually received;
- exclusion from the competition;
- exclusion from the entire tournament;
- temporary suspension;
- permanent suspension [“radiation”];
- disqualification;
- expulsion from the site of the competition.

§ 2. Fencing penalties

a) Loss of ground (see 43)

624 The fencer who has crossed over the lateral boundaries of the strip may be penalized by the loss of ground, which is one meter in foil and two meters in sabre and épée.

b) Refusal to award a touch actually made

625 Although a fencer may actually have made a touch on his opponent's valid surface, the touch may not be awarded, either because it was not made during the time allowed for fencing, or because it was made after he had left the limits of the strip, or because of some defect in the electrical apparatus, or because the touch was accompanied by a violent act [unnecessary roughness] or because of any other reason set forth in the rules (see 28, 30, 32, 35, 38ff, 42, 47, 73f, 230f, 237, 324ff, 422, 638ff, 645).

c) Award of a touch not actually received

626 A fencer may be penalized by a touch that he has not actually received, either because the time has expired (penalty against both fencers), or because he has crossed the rear limit of the strip, or because of an offense which prevents his opponent from fencing (a flèche that jostles the opponent, an intentional corps à corps in foil and in sabre, use of the unarmed hand, etc.) (see 30, 40, 48f, 224, 226, 321, 326, 412, 414, 638ff, 654, 657).

d) Exclusion from the competition

627 A fencer who commits while fencing certain violent or vindictive acts against his opponent, as well as one who does not honestly defend his chances, or who profits from a fraudulent agreement with his opponent, may be excluded from the competition.

The fencer who has been excluded from a competition cannot continue to take part in that competition, even if he has qualified for the next round; but the points obtained by this fencer as of the time of his exclusion remain his for the classification of his team for the team championship, provided that he actually participates in this championship.

In a team event, this penalty does not necessarily involve the disqualification of the team, but the touches that can still be made in the bout in progress, as well as all those that could be made in the course of the bouts remaining to be fenced by this competitor, will be scored against him.

The Director will decide if the fencer is to be excluded solely from the team match in progress, or if he will recommend to the Directoire Technique that he be excluded from all the team matches that his team may still have to fence (in the latter case, he may be replaced in these other matches by a substitute) (see 569).

§ 3. Disciplinary penalties

e) Exclusion from the competition

628 Exclusion from a competition may also be imposed for a disciplinary offense (failure to appear on the strip, weapons not conforming to the rules, reprehensible attitude toward a judge, etc.).

The consequences for the fencer of this exclusion are the same as those set forth in sub-paragraph d of §2 preceding.

f) Exclusion from the entire tournament

629 A fencer excluded from the entire tournament will no longer be allowed to take part in any competition at that tournament, either in the same weapon or in another weapon.

When the penalty is imposed on a team, the situation of each of its members must be individually examined, and a member of this team may be the object, according to circumstances, of disciplinary measures different from those applied to the others (see 609).

g) Suspension

630 A suspended fencer may not take part in any international competition during the time of his suspension.

All other persons who are suspended may not exercise their functions within the limits of time and place fixed by that suspension.

h) Permanent suspension [“radiation”]

631 Permanent suspension involves the same consequences as suspension, but differs by being permanent (except for the special provisions for clemency described in Article 665 below).

i) Disqualification

632 The disqualification of a fencer (for example: for violation of the amateur rules, or because he does not meet the requirements of the competition, as to age, qualification, etc.) does not necessarily involve his temporary or permanent suspension, if he has acted in good faith; however, a request for supplementary penalties for fraudulent intent may be entered against this fencer (see 650).

A team having used a disqualified fencer necessarily shares in his

penalty and is likewise disqualified.

If the disqualification occurs during the course of a pool or team match, the fencer or team will be regarded as having abandoned the competition (see 532ff).

If the disqualification occurs after the competition, the fencer or team is eliminated from the classification, and all the others are maintained in their respective classifications; the elimination will have no retroactive effect on the previous competition for qualification.

j) Expulsion from the site of the competition or tournament

633 All the participants or persons present (coaches, trainers, technicians, aides, officials, spectators) are subject to expulsion—which has the effect of prohibiting them access to the site of the competition or tournament for its duration.

This procedure cannot furnish grounds for relief [or damages] to anyone.

§ 4. Announcement of penalties

634 The Organizing Committee is obliged without delay to inform the national federation to which it belongs of the decision reached by itself, by the Directoire Technique, or by the Jury of Appeal; the national federation must make a record of the penalty and immediately inform the Central Office of the FIE. The latter will also make a record of the decision and see to its publication in the official journal.

At the Olympic Games, when the FIE takes the place of the Organizing Committee, the Central Office must inform the Olympic Games Committee.

**CHAPTER IV – OFFENSES, THEIR PENALTIES,
AND THE COMPETENT AUTHORITY**

§ 1. Preliminary note

635 In general, the present chapter merely repeats and coordinates the disciplinary measures mentioned in the various preceding parts. In case of difference between the Articles that follow and one of the preceding Articles, the latter is authoritative.

Offenses are classified as “offenses committed while fencing” and “offenses against sportsmanship, against good order, and against discipline.” The references call attention to the Articles in the previous Parts that are concerned with these offenses and their penalties.

With each offense there is listed the penalty it entails as well as the competent disciplinary authority.

§ 2. Warning [“avertissement”]

636 When an offense is punished only after a prior warning, the warning must have been given to the fencer at fault either in the course of the same bout, the same pool, the same team match, or during the matches by direct elimination (see each case).

§ 3. Offenses committed while fencing

a) Competent authority

637 All offenses committed while fencing are within the competence of the Director.

b) Offenses concerned with the field of play

638

1. For occasionally crossing the lateral boundary, both:

–loss of ground (foil: one meter; sabre and épée: two meters), without warning (see 43), and

–annulment of any touch, made by the fencer who leaves the strip, that arrives when he has already left it, as well as any touch initiated against this fencer once he has left the strip (except for the immediate riposte), without warning (see 38).

2. For crossing the lateral boundary in order to avoid a touch:

–penalty of one touch, after a warning given in the course of the same bout (see 43).

3. For crossing the rear limit of the strip:

–penalty of one touch, after a warning given at the warning line (see 40).

c) Offenses concerning the duration of the bout

639

1. For a touch initiated before the command “Fence” or after the “Halt” (see 32):

–annulment of the touch, without warning.

2. When the time limit for the bout is reached:

–addition to the score of each fencer of a certain number of touches, after a warning given at one minute before the expiration of the time (see 49, 226, 321, 414), or a double defeat (in épée) (see 321).

3. For improperly causing or prolonging interruptions in the bout:

–penalty of one touch, after a warning given in the course of the same bout; exclusion from the competition in case of a repetition (see 48).

d) Improper use of the unarmed hand or arm

640 1. In all three weapons, annulment of the touch that may be made by the offending fencer on his opponent and the penalty of one touch after a warning given in the course of the same pool, the same team match, or during the matches by direct elimination (see 30 and 31).

2. In foil, for protecting or covering, in the course of fencing, the valid surface with the unarmed hand or arm—after a warning given in the course of the same bout (see 30, 31):

–if there was no valid touch made by the offending fencer, the penalty of one touch added to the score against the fencer penalized.

–if there was a valid touch made by the offending fencer, the annulment of that touch.

–however, since a bout may not be won by the application of this penalty, in such case the penalty for the offending fencer will be either the removal of a touch that he has scored or the annulment of the valid touch that he has made.

In case the score of the fencer to be penalized is zero, the penalty will be the annulment of the first valid touch he scores, and successively, as necessary, of further valid touches he scores in the course of the bout.

e) Seeking the corps à corps in foil and in sabre

641

Penalty of one touch—after a warning given in the course of the same bout (see 224, 412).

f) Removal of the mask before the Director’s decision (see 28).

641add After a warning given in the course of the same bout:

–If there was no valid touch made by the offending fencer, the penalty of one touch added to the score against the fencer penalized.

–if there was a valid touch made by the offending fencer, the annulment of that touch.

—however, since a bout may not be won by the application of this penalty, in such case the penalty for the offending fencer will be either the removal of a touch that he has scored or the annulment of the valid touch that he has made.

In case the score of the fencer to be penalized is zero, the penalty will be the annulment of the first valid touch he scores, and successively, as necessary, of further valid touches he scores in the course of the bout.

g) For dishonest or incorrect fencing

642 —exclusion from the entire tournament—after a warning given in the course of the same pool or the same team match or during the matches by direct elimination (see 28, 605ff).

h) For seeking to favor an opponent

643 —exclusion from the competition—after a warning given in the course of the same bout (see 607).

i) For having profited from collusion with an opponent

644 —exclusion from the competition—after a warning given in the course of the same bout (see 607).

j) For violence and brutality [unnecessary roughness]

645 1. For all violent actions resulting from disorderly fencing and from abnormal positions, or from any action that the Director judges dangerous, for example, a running attack made with loss of balance, or for a blow delivered brutally:

— warning valid for the whole pool or team match or during the matches by direct elimination;

— one penalty touch in case of a repetition;

— exclusion from the competition in case of a second repetition

2. For having provoked a corps à corps with intentional brutality (even in épée), for a blow given the adversary with the hilt, the pommel, or the guard in the course of infighting:

— exclusion from the competition—after a warning given in the course of the same pool, the same team match, or during the matches by direct elimination (see 28, 605).

3. For a flèche that jostles the opponent:

— after a warning given in the course of the same pool, the same team match, or during the matches by direct elimination (see 28 and 605)—annulment of the touch thus made; upon a repetition, exclusion from the competition.

4. For having committed a vindictive act against one's opponent (a brutal hit or a sabre cut intentionally made on an invalid area):

— exclusion from the competition—after a warning, or even without a warning, as the Director sees fit (see 28).

k) For indisposition (including a cramp)

646 — withdrawal from the competition—after a rest period of ten minutes maximum has already been allowed in the course of the same pool, team match, or during the matches by direct elimination (see 51).

l) For an accident

647 1. Withdrawal from the competition after a rest period of 20 minutes (see 50).

2. Withdrawal from the competition of a fencer whose physical incapacity is obvious (see 52).

§ 4. Offenses against sportsmanship

a) Non-conformity of a fencer's equipment with the rules (see 21).

648 1. In every case, confiscation of the non-conforming equipment.

2. When the non-conformity may have been caused by the fencing and is discovered in the course of fencing: neither warning, nor penalty.

3. When the non-conformity may have been caused by the fencing but is discovered at the fencer's appearance on the strip: a warning, then a penalty touch for each repetition in the same pool, the same team match, or during the matches by direct elimination.

4. When the non-conformity cannot have been caused by the fencing, whenever it may be discovered: annulment of the touch that may have been made, and a warning, and then a penalty touch for each repetition in the same pool, the same team match, or during the matches by direct elimination.

As a bout cannot be won through the application of these penalties, the penalty to be imposed on the fencer at fault will thus be either the removal of a touch that he has scored or the annulment of the touch he has just scored. In case the score of the fencer penalized is zero, the penalty will be the annulment of the first valid touch he scores, and successively, as necessary, of further valid touches he scores in the course of the bout.

5. When the non-conformity can be the result of fraud: after consultation with the expert on duty, annulment of the touch that may have been made, and a penalty touch, and then exclusion from the entire tournament in case of a repetition in the course of the competition.

6. When the non-conformity arises from manifest fraud: exclusion from the entire tournament, after consultation with the expert on duty.

7. All penalties imposed for irregularity in a fencer's equipment shall be communicated to the Central Office of the FIE which will notify all the federations.

b) Placing an uninsulated part of the weapon in contact with the metallic vest in order to block the operation of the scoring machine (see 230).

1. Annulment of the touch that may have been made by the fencer who blocked the machine.

2. In case of a repetition, annulment of the touch that may have been made and—after a warning valid for the whole pool, the same team match, or during the matches by direct elimination—the penalty of one touch.

3. In case of another repetition, exclusion from the competition.

c) Non-observance of the regulations for the competition.

649 When a fencer does not comply with the regulations for the competition, for example, by assuming a qualification that he does not have:

— the Directoire Technique may disqualify him (see 632).

d) Violation of the rules on amateurism

650 A fencer who is convicted of having violated the rules of amateurism may be disqualified as an amateur by the Central Office of the FIE, either on their own initiative, or at the request of the Directoire Technique, or also on a complaint from an opponent (at the Olympic Games, by the Executive Committee of the International Olympic Committee) (see 619).

e) For having practiced doping

651 For having contravened the rules on "doping" (see 608):

– exclusion from the entire tournament by the Directoire Technique, and possible subsequent suspension by the Central Office of the FIE, either on its own initiative, or at the request of the Directoire Technique or of the Jury of Appeal (see 608).

f) Partiality by judges

652 For having been convicted of giving an intentionally partial judgment:

– disqualification as judge for the entire tournament, enforced by the Directoire Technique; with the possible extension of this penalty, either for a time or permanently, by the Central Office of the FIE, either on its own initiative, or at the request of the Directoire Technique or of the Jury of Appeal (see 610).

g) For any other offense against sportsmanship

653 – exclusion from the competition or from the entire tournament (by the Directoire Technique), suspension or permanent suspension (by the Central Office of the FIE).

§ 5. Offenses against the maintenance of order

a) For failure to appear on time (see 604)

654 For the fencer who does not appear, or for the team which does not appear complete, at the call of the Director at the time announced for the beginning of the pool or team match or for the beginning of the matches by direct elimination:

– a double repetition of the call at one minute intervals, followed by exclusion from the competition by the Director, if the fencer or complete team is not present at the third call.

In the course of a competition (for individuals or for teams) when the fencer has been notified that his turn to fence is about to come up, if he does not appear immediately at the Director's first call:

- a warning valid for each bout.
 - one penalty touch in case of a repetition.
 - exclusion from the competition in case of a second repetition.
- Similarly, if a fencer abandons a bout by leaving the strip (see 32/4):
- a warning valid for each bout.
 - one penalty touch in case of a repetition.
 - exclusion from the competition in case of a second repetition.

b) For any fencer interfering with the maintenance of order

655 For any fencer who, by gesture, attitude, or word interferes with the maintenance of order (see 602f):

– exclusion from the competition and when necessary from the premises where it is taking place, ordered by the Director after or even without a warning, but this shall not exempt the offending fencer from other possible penalties.

c) Spectators or supporting personnel interfering with the maintenance of order

656 For any spectator, coach, trainer, technician or other aide who interferes with the maintenance of order (see 611f):

– expulsion from the site of the competition by the Director, or the Directoire Technique, or the Organizing Committee, with or even without warning.

§ 6. Offenses concerning discipline

657 For every offense against the disciplinary code, refusal of immediate obedience to orders of the Director or of other officials (see 602, 609):

- a warning valid for each bout.
- one penalty touch in case of a repetition.
- exclusion from the competition in case of a second repetition.

CHAPTER V – PROCEDURE

§ 1. Principle

658 The various penalties are inflicted by the competent authorities who will reach their decisions in an equitable manner without being restricted to any procedural regulations, while taking into account the gravity of the offense and the circumstances under which it was committed (but see 661f).

§ 2. Protests [complaints] and appeals

a) Against a Director's decision

659 No protest can be made against the decision of a Director on the materiality and the validity [right of way] of a touch. However, if the Director ignores a formal prescription of the rules, or makes a decision contrary to the rules, a protest may be entertained on this ground.

Such a protest must be made verbally to the Director by the fencer or by the team captain, courteously although without formality, but immediately and before any decision is made on a subsequent touch.

If the Director holds to his opinion, the competent body to receive an appeal is the Directoire Technique (or the Organizing Committee) (see 615).

b) Other protests and appeals

660 Complaints and protests must be submitted in writing within a maximum period of one hour after the incident involved; they are to be addressed to the Directoire Technique or to the Organizing Committee.

Protests regarding the composition of pools will be entertained only until noon of the day before the competition, since the official posting of pools must have been made 24 hours before the beginning of the competition.

§ 3. Investigation: Right of defense

661 No penalty can be imposed until after an inquiry at which the interested persons are called upon to offer their explanations, either verbally or in writing, within a reasonable interval of time appropriate to the circumstances of time and place. After this interval of time has expired, the penalty may be imposed.

§ 4. Method of decision

662 The decisions of all jurisdictional bodies are taken by majority vote; in case of a tie the presiding officer's vote prevails.

§ 5. Reprieve

663 If the person concerned has not previously incurred a penalty of disqualification or of suspension, either for the same offense or for one substantially similar, with or without a reprieve, the authority which imposes the penalty may, at the same time, grant a reprieve [period of probation], the duration of which shall be twice that of the suspension ordered.

If, during the period of the reprieve [probationary period], beginning with the date of the decision imposing the penalty, the person concerned does not incur any new penalty, the original penalty is annulled. If the contrary should be the case, the first penalty shall take effect and be added to the new penalty.

§ 6. Repetition of offense

664 For offenses against sportsmanship, the maintenance of order, or discipline, a repetition has occurred when a fencer commits a fresh offense, other than a breach of the rules concerning the fencing of bouts:

- within a period of two years, if he has previously been censured or warned;
- within a period of five years, if he has previously been suspended, or subject to exclusion, or disqualified.

In case of a repetition, the minimum penalty to be imposed is:

- a) exclusion from the competition (fencers), suspension from the entire tournament (officials), expulsion (spectators), if the previous penalty was a warning or censure.
- b) disqualification from the entire tournament, if the previous penalty was exclusion from the competition.
- c) suspension for a period twice that of the previous suspension, or permanent suspension, if the previous penalty was suspension (fencers or officials).

§ 7. Pardon, remission and commutation of penalty

665 In exceptional cases, the Central Office and the Congress of the FIE, or a national federation, may, after special deliberation, pardon a fencer whom they have punished, remit the remainder of his penalty, or commute the penalty.

PART SEVEN: EQUIPMENT FOR THE AUTOMATIC REGISTRATION OF TOUCHES

CHAPTER I — RULES APPLICABLE TO ALL EQUIPMENT FOR THE REGISTRATION OF TOUCHES

§ 1. Authorized types

701 The only authorized types are electrical machines using wires to connect the fencers to the central apparatus and giving their principal signals by lamps, with auxiliary acoustical signals; radio wave (wireless) devices and those using only acoustical signals are excluded.

§ 2. Composition of the equipment

702 The complete electrical scoring equipment comprises:

- a) **Equipment furnished by the organizers of a competition, viz.:**
 1. The scoring machine, with extension lamps (see 709, 713ff, 723ff).
 2. The reels, with floor cables and connectors (see 710, 717, 730); or the use of a system of suspended cables (see 710/7).
 3. The metallic strip to ground out [neutralize] touches on the floor (see 711).
 4. The source of electrical power (batteries) (see 709/7, 716, 729).
- b) **Equipment furnished by the fencers themselves**
 1. The weapon, equipped with a connector inside the guard, and at the tip of the blade with a special scoring point (see 712, 718ff, 731ff).
 2. The body wire, with connectors for the reel and the weapon (see 710/2).
 3. The metallic vest ["plastron"] (used for foil only) (see 722).

§ 3. Approval of models of scoring equipment

703 Scoring equipment intended for use at an official FIE competition must have been approved by the Commission on Electrical Scoring and Equipment of the FIE.

To secure this approval, the equipment intended for use must be presented, complete with reels, connectors, etc., for inspection by the aforesaid Commission, at a time and place convenient to the Commission, and at least six months before the date of the competition.

The machine must be accompanied by a schematic diagram of its construction.

704 The approval is given for use in a particular official competition. The Commission will, however, within the limits of its capabilities, examine free of charge prototypes of designs submitted by their manufacturers, even if they are not intended for use in a forthcoming official competition.

705 An approval is given for only one particular model of machine, which conforms to the schematic diagram provided, and not in general terms for the entire production of one or another manufacturer. The latter may state in advertising only the fact that the model offered for sale has been used for some one or other official competition (provided this is the case); but they must themselves guarantee the conformity of their machine to the approved model.

706 Approval of a machine by the Commission, as well as its acceptance (see § 4 below), implies no guarantee against possible errors in construction.

707 All costs incurred by the Commission for the examination of equipment are at the expense of the interested parties.

§ 4. Inspection of scoring equipment before each competition

708 Before each official competition of the FIE, the proper functioning of the machines to be used, and their conformity to the approved model, must be verified by a delegate of the Commission on Electrical Scoring and Equipment of the FIE; this inspection is independent

of the inspection for approval of the model mentioned in § 3 above (see 705).

The equipment must be made available to this delegate at least 48 hours before the beginning of the competition.

§ 5. Specifications to be met by all electrical equipment

a) Scoring machine (see 713ff, 732ff)

709 1. A touch landing on the metallic strip or on the metal parts of the weapon must not be registered and must not prevent the registration of a touch made simultaneously by the opponent.

2. The machine must not include any device that would permit anyone besides the machine operator to interrupt its working during the fencing.

3. Touches are indicated by signal lamps. These lamps are located on the top of the machine, in order to be visible to the Director, the fencers, and the machine operator. By their position they must indicate clearly on which side the touch has been scored. It must be possible to add extension lamps apart from the machine to improve the visibility of the signals. However, in case of any difference between the signals on the machine and those on the extension lamps, the lamps on the machine rule.

4. The signals, once lit, must continue lit until the machine is reset, without any tendency to go out or to flicker, whether as a result of subsequent touches or vibrations.

5. The lamp signals are accompanied by acoustical signals (see under each weapon) (see 713/3, 728).

6. Switches for working the machine must be located on the top or on the front of the apparatus.

7. The machines are powered by current from batteries, without any connection to the general electrical lines.

b) Reels, floor cables and connectors (see 717, 730)

710 1. The maximum resistance of each wire in the reel from socket to socket is 3 ohms.

2. Even when the reel is in full rotation, no interruption of contact can be tolerated. To prevent interruptions, contact rings should have double brushes. For connection through the frame of the reel, the conductor connected to the metal of the weapon will be used.

3. Reels should allow for the unrolling of from 18 to 20 meters of wire without weakening the springs.

4. The female connector of the reel wire intended to receive the male connector of the body wire at the fencer's back must include a safety device that meets the following conditions:

- it shall be impossible to fasten, if the connection is not properly made;
- it shall be impossible for it to come apart in the course of a bout;
- it shall be possible for the fencer to verify that both the preceding conditions have been met.

5. The resistance of each of the three wires in a floor cable may not exceed 2.5 ohms.

6. The connectors serving to attach the body wire to the reel wire and the floor cables to the reels and the machine have three pins, 4 mm in diameter, arranged in a straight line, with the end pins spaced respectively 15 and 20 mm from the center pin. The body wire and the floor cables have male plugs; the machine and reels have the female sockets for these plugs.

7. The use of suspended cables to replace reels is permitted, provided that the provisions of the preceding paragraphs are met.

c. Metallic strip

711 1. Metallic strips are made of metal, of metallic mesh, or of a material with a metallic base. The resistance in ohms of the metallic strip, from one end to the other, may not exceed 5 ohms.

2. The conductive metallic strip must cover the full width of the strip over all its length, including the extensions.

"When a competition is fenced on an elevated platform, the metallic strip must cover the full width of the platform" (a provision mandatory for official competitions of the FIE).

3. Since the reels have a limited length of wire, the metallic strips are designed for a strip length of 14 meters so as to give épée fencers the ground twice; there are added 1.5 to 2 meters at each end, for the retreat of the fencers. The metallic strip must, therefore, be 17 to 18 meters long over-all.

4. Metallic strips are preferably mounted over wooden strips, with a soft material in between. They are equipped with a device to permit them to be kept well stretched.

5. The paint used to mark out lines on metallic strips must be of a sort that does not reduce the conductivity; touches that land on the painted lines on a strip must be properly grounded out.

6. The organizers must have available soldering materials, to permit immediate repair of holes that are made in the strip (see 231/8, 328).

d. Weapons (see 718ff, 731ff)

712 1. Inside the guard there must be a pad large enough to protect the electrical wires from the fencer's fingers. The arrangement of the connectors must be such that it is impossible for the fencer to cause interruptions or make contacts in the course of a bout (see 26).

In foil, the wire must be protected by an insulating sleeve.

In epee, the wires must be protected by two insulating sleeves, one for each wire.

The wire and its insulating sleeve will be brought to the immediate proximity of the fixed socket.

In any case, uninsulated wires may not extend beyond the sockets (see 214, 314).

2. Inside the guard, any design of connector is permitted, provided that it meets the following general conditions:

- it must be easy to connect and disconnect.
- it must allow tests by simple tools, such as a pen knife or coin.
- it must be possible easily to apply the opponent's point to the part connected to the blade.
- it must be equipped with a security device that prevents disconnection in the course of a bout.

- it must guarantee absolutely continuous contact of the electrical connections: even a momentary interruption, while the connection is maintained, must be impossible.

3. The resistance in ohms required for the weapons is set forth under each weapon.

Persons who want to assemble electrical weapons, without having the equipment to make electrical tests, are advised that the limits for resistance in the circuits, as set forth for each weapon, have been chosen so that any-

one who exercises a minimum of attention to his work should be able to meet them.

It is recommended:

- to deoxidize thoroughly the external surface of the guard and the contact surfaces inside the guard;
- not to damage the insulation of the wires especially in the parts where they pass through the grooves cut in the blade at the button and at the guard;
- to avoid accumulations of glue in the groove of the blade.

CHAPTER II - SPECIAL REQUIREMENTS TO BE MET BY THE VARIOUS PARTS OF ELECTRICAL FOIL EQUIPMENT

A. FIXED EQUIPMENT

§ 1. Scoring machine [Central apparatus] (See 709)

a) Principles

713 1. The scoring machines work by the interruption of the current flow in the foil circuit; i.e., a continuous flow of current in the foil circuit is broken when there is a touch.

2. The machines will give a red signal on one side and a green signal on the other for touches on valid surface; the signal will be white on both sides for touches on an invalid surface.

3. The acoustical signals will be either a brief ring or a continuous sound automatically limited to two seconds duration, either being produced at the same time as every optical signal. The sound will be the same for both sides.

4. After having signalled an invalid touch, the machine must still be able to signal a valid touch made against the same side.

5. On the other hand, after the signalling of a touch on a valid surface, the machine must not show a subsequent touch on the invalid surface of the same side.

6. The machine will not indicate priority of a touch scored by one fencer over a touch scored by the other.

7. On the other hand, after a certain time "X" (which bears no relation to "fencing time," the foundation of judging in the conventions for foil), after the first signal is given by the machine, the mechanism will block out any further signals. The central apparatus must permit the regulation of this time "X" between 1 and 2 seconds. Machines will be adjusted for a 2 second time.

b) Sensitivity and reliability

714 1. Every touch must produce a signal, whatever may be the resistances of the circuits external to the machine. The length of the interruption of the circuit that must always produce a signal is 5 milliseconds.

With increase of resistance, the registration of the machine may produce:

- (a) only a valid touch,
- (b) simultaneous valid and invalid touches,
- (c) only an invalid touch.

The value of resistance must always be less than 500 ohms for conditions (a) and (b).

2. The registration of a valid touch signal must occur in the following conditions:

| Resistance of the return circuit through the opponent's metallic vest: | Duration of the break of contact by which the signal must be guaranteed: |
|--|--|
| - 100 ohms | 5 milliseconds |
| - 250 ohms | unlimited |

3. The registration of the invalid signal must occur when there is an interruption of the circuit of from 2 to 10 milliseconds, when the exterior resistance is normal, i.e., 10 ohms.

4. The machine must be able to sustain an increase of resistance in the closed circuit of the foils amounting to as much as 200 ohms, without registering an invalid touch signal.

5. Even if the resistance in the blade circuit of the foil should increase to as much as 100 ohms, neither of the following irregular phenomena may occur:

- registering of touches against the guard,
- registering of touches solely by contact of the flat of the foil, or of the point when not depressed, against the metallic vest of either of the fencers.

6. If a breakdown of the insulation in a fencer's equipment creates a leakage of current between his weapon and his metallic vest, corresponding to a resistance of 250 ohms, the machine still ought to register the touches exchanged in a normal manner.

7. A schedule of tests for scoring machines, under varied conditions, may be obtained on application to the Commission on Electrical Scoring and Equipment of the FIE.

8. The Congress of the FIE has authorized this Commission to modify or extend the requirements set forth above, each time that technical progress enables the construction of apparatus that can produce better results in the electrical signalling of touches in foil.

c) Extension lamps (see 709/3).

715 Extension lamps located apart from the scoring machine are required for the official FIE competitions. The lamps will be located approximately 1.8 meters above the strip. The two lamps of the same group may not be more than 15 centimeters apart, and the groups will be located at a distance of at least 50 centimeters from each other.

The extension lamps should be arranged in the same order as the white and colored lamps on the machine (see 713/2).

d) Source of electrical power (see 709, 729)

716 1. Machines must be designed to work on a 12 volt supply, or in case of separation of the supplies for the two sides, 2 x 12 volts, or even 2 x 6 volts. (The separation of the power supply is recommended, as it helps to solve several problems encountered in the construction of foil machines).

2. The power supply is normally furnished by batteries. The socket provided on the machine for this connection must be so constructed as to make impossible an accidental connection to the general source of electrical power.

3. Machines may include pilot lamps to show that the foils are in the circuit. These lamps should be uncolored.

§ 2. Reels, floor cables and connectors

(See 710)

717 In foil, the attachment of the various leads to the three pins of the reel sockets is as follows:

- pin 15 mm from the middle: to the metallic vest.
- central pin: to the wire in the foil.
- pin 20 mm from the middle: to the metal of the blade and the metallic strip.

— the crocodile clip on the body wire must be a sturdy type and guarantee very good contact with the metallic vest.

The wire connecting the crocodile clip to the rear plug of the body wire must have a free length of at least 40 cm and be soldered to the crocodile clip. This solder joint may not be covered by insulation or any kind of material. The body wire and connectors must meet the specifications for manufacture and assembly as defined in Article 217.

B. WEAPONS (see 712)

§ 1. Principle

718 The foil has a single wire, glued into a groove cut the length of the blade, permanently connecting the point to the corresponding socket inside the guard. At rest, the point is also in contact with the metal of the blade. When there is a touch, this contact is broken.

§ 2. Points and buttons

719 1. The diameter of the point is between 5.5 mm and 7 mm; the diameter of the body of the button, including the insulation on the outside, may not be more than 0.3 mm less than that of the point.

2. The point is cylindrical. Its front surface is flat and perpendicular to its axis.

At its edge it will either be rounded off with a radius of 0.5 mm or have a chamfer of 0.5 mm at 45°. The diameter of the crown (top) of the point is between 5.5 mm and 7.0 mm. The diameter of the body of the button, including the insulation on its exterior, may not be more than 0.3 mm less than that of the crown.

3. The pressure required upon the point to break the contact and cause the scoring machine to operate must be greater than 500 grams; i.e., this weight must be pushed back by the spring in the button (see 211).

4. The distance traveled by the point necessary to cause the scoring machine to register a touch, a distance called the "lighting stroke," may be infinitely small; the total travel of the point is one millimeter at most.

5. The point must be held in the button at two equally spaced locations, at least, or by some other system after approval by the Commission on Electrical Scoring and Equipment.

§ 3. Attachment of the button

720 If the base of the button is not in one piece with the blade, or does not allow for the retention of the flat surface at the end of the blade, it must be screwed onto the end of the blade which has been cut and threaded to receive it, according to the following specifications:

1. Normally, only attachment by metal to metal is permitted. However, attachment by means of some insulating material having great mechanical strength may be permitted after approval by the Commission on Electrical Scoring and Equipment.

2. All soldering or brazing operations, or in general all procedures involving heat that could affect the temper of the blade, are prohibited. Only a very fusible tin solder, applied with a soldering iron merely to fix the thread, is authorized.

3. After threading, the end of the blade may not, at any place, have a diameter less than 3.5 mm—and this without any wrapping procedures, which are strictly prohibited.

4. For a steel button, the threading will have a core diameter of 2.7 mm (SI 3.5 x 0.60 thread). The threading must be very closely cut.

The part of the blade onto which the button fits must be 7 to 8 mm long and be entirely covered by the button. It is recommended that only the outer half of this length be threaded. In the other half the button will have a smooth interior surface of 3.5 mm diameter, into which the corresponding part of the blade must be fitted with some force.

5. For a button of light alloy, a decision must be sought from the Commission on Electrical Scoring and Equipment.

6. At the place where the wire enters the button, the width of the groove in the blade may not exceed 0.5 mm and its depth may not exceed 0.6 mm, measured on the diameter of the core of the threading, in order to weaken the cross-section as little as possible.

7. Only the members of the Commission on Electrical Scoring and Equipment or the *Directoire Technique* may demand the verification of the points set forth above.

§ 4. Insulation of the button and the blade

721 The body of the button and the blade of the foil, for a distance of 15 cm from the button, as well as the pommel or rear extremity of the handle, must be entirely covered by an insulating material (insulating tape, adhesive tape, plastic, or varnish) (see 211).

The flange of the sleeve which slides in the base of the button and which supports the core of the point, must have a diameter less than that of the insulated top of the point, to prevent any accidental contact with the metallic vest during a touch.

C. METALLIC VESTS, MASKS AND BODY WIRES

722 1. The metallic vest must cover the fencer's valid surface [target] completely, and without omission. Specifications for its dimensions are given in Part TWO (see 217, 220).

2. The interior of metallic vests must be electrically insulated, either by a lining or by some effective treatment of the lamé.

3. The lamé used must have metallic threads in both warp and weft; its electrical conductivity must meet the following specifications:

a) the electrical resistance, measured between any two points on the surface of the lamé, may not exceed 5 ohms. To measure the resistance of the lamé a 500 gram weight of copper or brass, having a hemispherical bottom with a 4 mm radius, is used. This weight, rested upon this bottom and moved about over the lamé, must produce continuous contact with a maximum resistance of 5 ohms.

b) in any case, holes or patches of oxidization or other material capable of preventing the registration of touches, cannot be tolerated.

c) a metallic vest which is judged to be unusable will be marked up with a highly visible colored paint by a member of the Commission on Electrical Scoring and Equipment.

4. The mesh of masks will be insulated inside and out, before all assembly procedures, by a shock-resistant insulating material.

5. Masks and metallic vests as defined here are mandatory for the official competitions of the FIE.

6. In any case, if, for any reason at all, a fencer's equipment does not conform to paragraphs 2, 3, and 4 above, Article 231 will not be applicable in case a valid touch signal is produced by a touch on an invalid surface.

7. The body wire, its connectors and its crocodile clip must meet the specifications for manufacture and assembly set forth in Article 217.

CHAPTER III — SPECIAL REQUIREMENTS TO BE MET BY THE VARIOUS PARTS OF ELECTRICAL EPEE EQUIPMENT

A. FIXED EQUIPMENT

§ 1. Scoring machine [Central apparatus]

a) Principle

723 The scoring machine registers when the wires of the epee circuit are brought into contact, thus permitting the current to flow.

b) Timing adjustment

724 The scoring machine must register only the touch that arrives first. If the time elapsed between two touches is less than 40 milliseconds (1/25 of a second), the machine must register a double touch (both signal lights go on simultaneously). Beyond 50 milliseconds (1/20 of a second), the machine must register only a single touch (only one signal light goes on). The range of tolerance necessary for adjusting the machine lies between these two limits (1/25 and 1/20 of a second).

c) Sensitivity

725 The registration of a touch must occur whenever there is a contact in the circuit lasting for 10 milliseconds, assuming that the external resistance is normal, i.e., 10 ohms. If the external resistance should be an exceptional 50 ohms, touches must still register, but in such a case there is no specification for the length of contact required.

d) Non-registration

726 Touches against the grounded circuit (guard or metallic strip) must not be registered, even when there is a 50 ohm resistance in that circuit.

e) Light signals

727 1. The light signals will include at least two lamps on each side, so arranged that the failure of one will neither prevent the other from lighting nor overload it.

2. The signal lamps must give a red signal on one side and a green signal on the other.

3. The machine must be furnished with a colorless, low-intensity pilot

lamp showing when the voltage is being applied.

4. The machine may include indicator lamps to show current flow to the grounded circuit. Such lamps will be orange colored.

5. The lamps showing the touches are normally covered with translucent shields. However, it must be possible to remove the shields and use the bare lamps when the illumination in the area is such as to make it desirable to do so (in bright sunlight or in the open air).

f) Sound signals

728 The sound produced by the scoring machine must be loud. The machine may include a device to shut off the sound before the machine is reset.

g) Source of electrical current (see 709, 716)

729 1. Scoring machines must be designed to work on a 12 volt current. The connector on the machine to receive this current must be so designed that it shall be impossible to connect the machine by mistake to the general electrical supply.

2. If the machine is designed to work from dry-cell batteries, it must be equipped with a voltmeter or other device that will permit the voltage in the batteries to be checked at any time. However, machines must always be equipped with the connectors mentioned above to permit them to be powered by external batteries.

§ 2. Reels, floor cables, connectors and body wires

(See 710)

730 In épée, the attachment of the various elements to the three pins or sockets of the reels and floor cables is as follows:

- pin 15 mm from the center: to the epee wire which is most directly connected to the point.
- central pin: to the other epee wire.
- pin 20 mm from the center: to the metal of the weapon and to the metallic strip.
- the body wire and the connectors for épée must meet the specifications for manufacture and assembly set forth in Article 314.

B. WEAPONS (see 712)

§ 1. Principle

731 The épée has two electrical wires glued into the groove of the blade, connecting, as described above, the button to two of the three connecting sockets inside the guard; these form the active circuit for the épée. The metal of the weapon is connected to the third socket.

§ 2. Points and buttons

(See 311)

732 1. The point is cylindrical. Its front surface is flat and perpendicular to its axis. At its edge it will either be rounded off with a 0.5 mm radius, or have a 0.5 mm chamfer at 45°.

The diameter of the crown of the point is 8 mm, with a tolerance of + or - 0.05 mm. The diameter of the base (the cylinder of the button) may not be less than 7.7 mm.

The flanged collar that guides the point, as well as any insulating material used, must be sufficiently recessed in relation to the crown of the point (a recess of 0.3 to 0.5 mm on the diameter is recommended) that it is not possible to cause touch signals merely by gliding the depressed point against the curved surface of the guard (see 326/2a and illustration).

The Tollbom point, of a design totally different from that described above, may be used in official FIE competitions and in other international competitions.

The diameter of the crown of this point is also 8 mm with a tolerance of ± 0.05 mm.

The lighting stroke must be more than 1 mm as for the customary point (see 732/4).

2. The pressure that must be exerted upon the point to close the *épée* circuit, and thus cause the scoring machine to register, must be more than 750 grams; i.e., this weight must be pushed back by the spring in the button (see 311).

3. The weight used to test the fencers' *épées* on the strip is a cylinder of metal bored for a part of its length with a hole parallel to its sides; this hole, into which the end of the blade is inserted, must be lined with insulation so that metal will not come into contact with the blade and falsify the test.

4. The travel of the point necessary to close the circuit in the *épée* and thus cause the scoring machine to register a touch, known as the "lighting stroke," must be greater than 1 mm. The remaining travel of the point must be less than 0.5 mm (a provision just as important as that for the lighting stroke).

To permit inspection on the strip, the total travel of a point must be more than 1.5 mm (see 18).

5. Points are held in the button at two locations equally spaced, at least, or by some other system after approval by the Commission on Electrical Scoring and Equipment.

§ 3. Attachment of the button

733 If the base (cylinder) of the button is not formed integrally with the blade, or does not permit the retention of the flat at the end of the blade, the button must be screwed onto the end of the blade, which has been cut and threaded to receive it, in accordance with the following specifications:

1. Normally, only attachment by metal to metal is permitted. However, attachment by an insulating material having great mechanical strength may be permitted after approval by the Commission on Electrical Scoring and Equipment.

2. All soldering or brazing operations, or in general all procedures involving heat that could affect the temper of the blade, are prohibited. Only a very fusible tin solder, applied with a soldering iron merely to fix the thread, is authorized.

3. Before threading, the end of the blade may not at any point have a diameter less than 4 mm—and this without any wrapping procedures, which are strictly prohibited.

4. The diameter of the core of the thread at the end of the blade may not be less than 3.05 mm (SI 4 x 0.70 thread).

The part of the blade onto which the button fits must be 7 to 8 mm long,

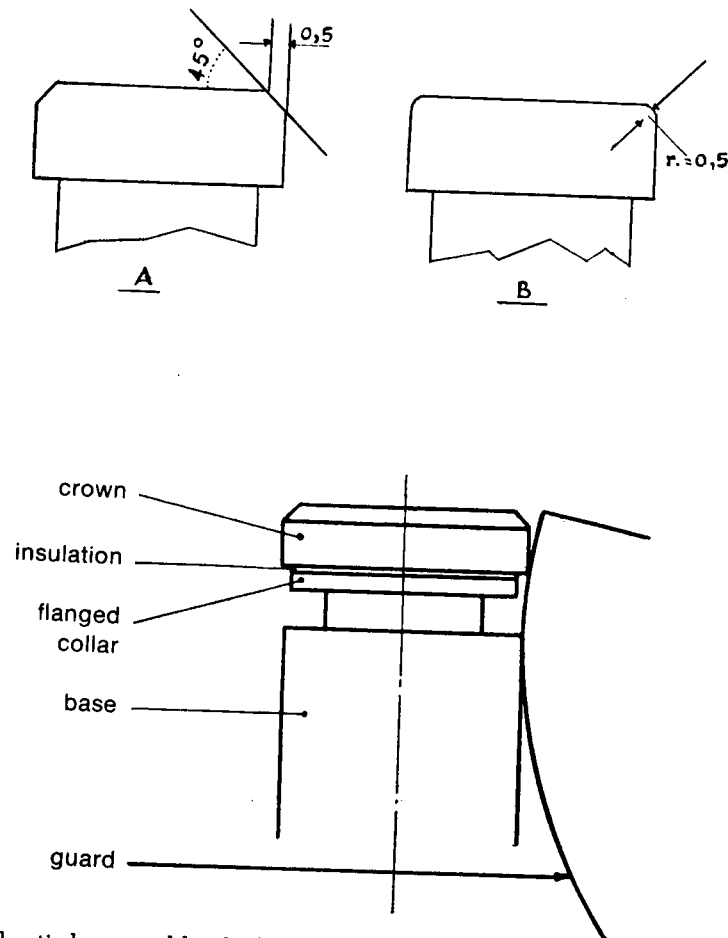

and entirely covered by the button. It is recommended that only the farther half of this length be threaded. In the other half, the button will have a smooth interior surface of 4 mm diameter, into which the corresponding part of the blade must be fitted with some force.

5. The groove necessary to pass the wires into the button must be cut in such a fashion as to weaken the cross-section as little as possible.

6. Only the members of the Commission on Electrical Scoring and Equipment or the *Directoire Technique* may demand the verification of the points set out above.

METRIC CONVERSIONS

Metric measurements encountered in fencing and their approximate equivalents in English measures.

| | | | |
|----------------|---------------------|-----------------|------------------------|
| 200 g | = 0.44 lb; 7.07 oz | 7.0 cm | = 2.756 in |
| 500 g | = 1.10 lb; 17.68 oz | 9.5 cm | = 3.740 in |
| 750 g | = 1.66 lb; 26.53 oz | 10.0 cm | = 3.937 in |
| 770 g | = 1.7 lb; 27.23 oz | 12.0 cm | = 4.724 in |
| | | 13.5 cm | = 5.315 in |
| 0.05 mm | = 0.00197 in | 14.0 cm | = 5.512 in |
| 0.3 mm | = 0.0118 in | 15.0 cm | = 5.905 in |
| 0.5 mm | = 0.0197 in | 17.0 cm | = 6.693 in |
| 0.6 mm | = 0.0236 in | 18.0 cm | = 7.087 in |
| 1.0 mm | = 0.03937 in | 20.0 cm | = 7.874 in |
| 1.2 mm | = 0.0472 in | 30.0 cm | = 11.811 in |
| 1.5 mm | = 0.0590 in | 40.0 cm | = 15.748 in (1.312 ft) |
| 2.1 mm | = 0.0827 in | 50.0 cm (0.5 m) | = 19.685 in (1.64 ft) |
| 2.4 mm | = 0.0945 in | 70.0 cm | = 27.559 in (2.296 ft) |
| 2.7 mm | = 0.1063 in | 88.0 cm | = 34.645 in (2.887 ft) |
| 3.0 mm | = 0.1181 in | 90.0 cm | = 35.433 in (2.953 ft) |
| 3.05 mm | = 0.1200 in | 95.5 cm | = 37.598 in (3.133 ft) |
| 3.5 mm | = 0.1378 in | 1.0 m | = 39.37 in (3.28 ft) |
| 4.0 mm | = 0.1575 in | 105 cm | = 41.338 in (3.445 ft) |
| 5.5 mm | = 0.2165 in | 110 cm | = 43.307 in (3.609 ft) |
| 6.0 mm | = 0.2362 in | 1.125 m | = 44.291 in (3.691 ft) |
| 7.0 mm | = 0.2756 in | 1.8 m | = 70.866 in (5.906 ft) |
| 7.7 mm | = 0.3031 in | 2.0 m | = 78.74 in (6.562 ft) |
| 8.0 mm | = 0.3149 in | 3.0 m | = 98.4 ft (8.562 yd) |
| 1.0 cm | = 0.3937 in | 5.0 m | = 16.4 ft (5.468 yd) |
| 1.5 cm (15 mm) | = 0.5905 in | 7.0 m | = 22.96 ft (7.653 yd) |
| 2.0 cm (20 mm) | = 0.7874 in | 10.0 m | = 32.81 ft (10.936 yd) |
| 2.4 cm | = 0.9449 in | 13.0 m | = 42.65 ft (14.22 yd) |
| 3.0 cm | = 1.181 in | 14.0 m | = 45.93 ft (15.31 yd) |
| 3.5 cm | = 1.378 in | 17.0 m | = 55.77 ft (18.59 yd) |
| 4.0 cm | = 1.575 in | 18.0 m | = 59.05 ft (19.685 yd) |
| 4.5 cm | = 1.772 in | 24.0 m | = 78.74 ft (26.246 yd) |
| 5.5 cm | = 2.165 in | | |

INDEX

- Unless otherwise noted, all references are to Articles.
- Abandoning a competition (see Withdrawal).
- Accidental events ["cas fortuit"], 44, 231.5, 327/j, 527.
- Accident, 16, 50, 63, 530, 565, 647.
- Accident, responsibility for, 16.
- Accumulators (see Batteries).
- Acknowledgement of a touch, 66, 72, 606, 655.
- Actions initiated, 32, 38f, 46, 47.
- Age of participants, 596.
- Aides (persons accompanying fencers), 611, 656.
- Allowance of ground, 39, 41.
- Amateur status (of fencers), 619, 650.
- Amateur status (of judges), 56.
- Annulment of a penalty, 621.
- Annulment of a touch, 73, 223, 230ff, 237, 324ff, 326f, 422, 615.
- Appeal against a decision, 614, 617, 659f.
- Appeal, frivolous, 611, 614.
- Appeal, ultimate, 614, 617f, 621.
- Appearance on time, 604, 654.
- Application of the rules, mandatory, 1.
- Approval of scoring machines, 703ff.
- Assault (see free play).
- Asseseurs (see Judges).
- Assistance on the strip, 611.
- Attachment of points, 210, 312, 720, 733.
- Attacks, 10f, 233ff, 417ff.
- Attention of judges, 55.
- Auxiliary personnel, 59ff, 204, 305, 516.
- Award of a touch, 21, 30, 31, 40, 48f, 224, 226, 321, 412, 414.
- Back edge (sabre), 409.
- Barrage (see Fence-off).
- Batteries, 709, 716.
- Beginning the bout, 32.
- Bend of blades, 207, 308, 406.
- Bib of mask, 27, 214, 221, 408.
- Bids, 579, 594.
- Blade, 23, 207, 308, 406, 720, 733.
- Blade, flexibility of, 207, 308, 406.
- Bodies having jurisdiction, 613, 658ff.
- Body wire, 217, 314, 710, 712, 717, 722, 730f.
- Boundary, lateral, 43.
- Bout, 4, 526ff.
- Bout Committee (see Directoire Technique).
- Bouts in direct elimination, 225, 319, 413.
- Breakage of a blade, 231/f, 327/h.
- Breakdown of a scoring machine, 60, 71.
- Breast protectors, 27, 215.
- Brutality, 28, 605, 645.
- Button, 23f, 210f, 311f, 324, 406, 702, 719ff, 732f.
- Calling fencers to the strip, 53, 604, 654.
- Candidatures (see Bids).
- Captain of a team, 565, 609, 618.
- Center lines, 31, 203, 303, 403.
- Central Office of the FIE, 504, 507, 514, 590, 613, 617f, 621, 634.
- Circumstances beyond one's control, 569.
- Championship, defined, 7.
- Changing ends of the strip, 32, 552.
- Changing hands on weapon, 30.
- Classification of fencers, 528, 531, 544, 548, 555, 557, 562.
- Classification of teams, 567, 577, 578.
- Close-quarters fencing, 33.
- Clothing, 27, 215ff, 315, 408.
- Coaches, 611, 656.
- Collar, metallic, 216.
- Collusion, 607, 644.
- Combat, 28ff (and see Fencing).
- Commission on Electrical Scoring and Equipment, 17, 60, 703ff, 708, 714, 720, 733.
- Committee, International Olympic, 505, 510, 613, 619.
- Commutation of a penalty, 665.
- Competence in jurisdiction, 613ff, 635, 637.
- Competitions ["Epreuves"], 6, 501, 522, 546ff, 571, 581, 588.
- Composition of pools for individuals, 524, 525, 542, 543.
- Composition of pools for teams, 575.
- Composition of teams, 565.
- Confirmation of a penalty, 621.
- Confiscation of equipment, 21, 648.
- Confused fencing, 28, 32, 231/7.
- Congress of the FIE, 614, 622, 665, 714.
- Connector for electrical current, 23.
- Connectors (plugs), 217, 314, 327/f, 712, 717, 730.
- Contact between fencers, 34.
- Contact of weapon and metallic vest, 230, 648.
- Control of equipment (see Inspection).
- Conventions of epee, 316ff.
- Conventions of fencing, 67.
- Conventions of foil, 232ff.
- Conventions of sabre, 416ff.
- Coquille (see Guard).
- Corps a corps, 34, 37, 224, 318, 412, 641.
- Counter attacks, 12.
- Counter riposte, 10.
- Counter time, 13.
- Coupé, 233/2, 418/2.
- Court of Appeal (see Jury of Appeal).
- Courtesy, 4, 28, 602.
- Covering the point, 210.
- Cramp, 51 and note, 646.
- Cross bars, 25.
- Crossing the boundaries, 38ff.
- Current, electrical, 716, 729.

Cutover (see Coupé).
Cuts through the steel, 409.
Cuts with the fore edge, 409.

Dangerous fencing, 28, 32.
Deciding bout ["belle"], 225, 319, 413, 551, 559.
Decisions, methods of, 662.
Decisions on matters of fact, 614.
Defense, right of, 661.
Defending one's chances, 607, 643f.
Defensive action, 10f, 30.
Delayed riposte (see Riposte, delayed).
Deliberations of the jury, 45, 68ff.
Derobement, 233/3, 237/2, 418/3, 422/2.
Deviation from the rules, 2, 505, 508.
Dimensions of the strip, 202, 302, 402.
Dimensions of weapons, 24f, 205ff, 307ff, 404ff.
Direct elimination, 6, 549, 558ff, 571ff, 577.
Direction of fencing, 53ff.
Directoire Technique, 57, 505, 509, 513, 589, 598, 610, 613ff, 617f.
Director (of combat), 3, 18f, 53, 61, 71, 615, 637, 659.
Director, disciplinary duties, 613, 615, 617.
Director, duties in directing, 53, 61, 63, 71, 615.
Director, duties in inspection, 18f, 71, 231, 327, 615.
Director, duties in judging, 61, 67ff, 72ff, 228, 237, 324, 416, 422.
Discipline, 602, 657.
Disciplinary authorities, 613ff.
Disciplinary Code, 601ff.
Disciplinary penalties, 628ff.
Disciplinary penalties, 628ff.
Disengagement, 11, 233ff, 418ff.
Disconnection of a plug, 71, 327/f, 712.
Displacements of the body, 35, 222.
Disqualification, 615, 617, 623, 632.
Distinctness of the touch, 29.
Disturbing the maintenance of order, 602f, 655f.
Doping, 608, 651.
Double touches, 38, 237, 329ff, 331, 422.
Drawing lots, 525, 530, 558.
Drawn team match, 567.
Dubious touch, 69/5, 74, 231/5, 327/j, 331, 422.
Ducking (see Evasive actions).
Duration of fencing, 32, 45f, 59, 225f, 319f, 413f, 552, 559, 639.

Eccentricity of blade mounting, 208, 310.
Elbow protector, 408.
Electrical scoring equipment (see Scoring equipment).
Elimination, direct, 6, 549, 558ff, 571ff, 577.
Elimination pools, 524f, 528, 542, 544.
Entry to a competition, 518, 580, 583, 586, 595.
Epée, 301ff.
Epée, electrical, 731ff.
Equipment, electrical, 701ff.

Equipment, épée fencers', 306ff, 731ff.
Equipment, fencers', 16ff, 27, 205ff, 216, 306ff, 313f, 404ff, 408, 702, 722.
Equipment, foil fencers', 205ff, 718ff.
Equipment, sabre fencers', 404ff, 408.
Evasive actions, 35, 237, 422.
Exceptions to the rules, 2.
Exclusion from a tournament, 629, 648.
Exclusion of a fencer, 21, 615, 623, 627, 628f, 639, 648.
Exclusion of a team, 628f, 648.
Experts in electrical equipment, 60/b, 71, 516/d.
Expulsion, 623, 633.
Extension of a penalty, 617.
Extension of the valid surface, 222.

Failure of equipment, 21, 231, 326, 648.
Falsification of equipment, 21, 648.
Fatigue, fencers', 519ff.
Favoring an opponent, 607, 643.
Federation, National, 579, 583, 594, 613, 620, 634.
Feints, 235, 418/2, 420.
Fence-off, 530, 531, 538, 544f, 555, 562.
Fencers, 601ff.
Fencing at close quarters, 33.
Fencing, duration of, 45ff.
Fencing, incorrect, 28, 605ff, 642.
Fencing, interruption of, 48.
Fencing, manner of, 28ff.
Fencing phrase (see Phrase d'armes).
Fencing time, 9, 236f, 421f.
FIE (see Central Office and Congress).
Field of play, 14ff, 201ff, 301ff, 401ff.
Finals of competitions, 58, 520f, 523, 531, 548, 555, 562, 578.
Fleche (attack), 37, 43, 69, 224, 318, 412, 645.
Flexibility of blades, 207, 308, 406.
Floor cables, 702, 710, 717, 730.
Floor judges, 54ff, 71f, 74, 610.
Foil, 201ff.
Foil, electrical, 211ff, 718ff.
Formulas for direct elimination, 522, 549, 558, 577.
Formulas for organizing competitions, 520, 521ff.
Formula, mixed, 541, 555, 574.
Following the action, 33, 61.
Fore edge cut, 409.
Fortuitous circumstances (see Accidental events).
Free play, 4, 28.
Frustrated appeal, 611, 614.

Gaining ground, 36.
Gauge (for measurements), 20, 25, 208, 310, 407.
Glossary of fencing terms, 3 to 13.
Glove, 27, 213, 408.
Grazing of the blades, 237, 422.
Grounding, electrical, of the guard, 327/g, 726.
Grounding, electrical, of the strip, 201, 304.
Guaranty deposit, 511, 614.
Guard (coquille), 23, 26, 208, 310, 326/a, 407, 712.

Guard: on-guard lines, 31, 203, 303, 403.
Guard, padding inside, 23, 26, 712.
Guard, placement on, 31, 37.
Guard, replacement on, 36, 37, 43, 226, 237/3, 320, 414/b, 422/3.

Halting the bout, 32, 38, 46, 47, 63, 223, 411.
Hand holding the weapon, 30, 640.
Hand, unarmed, 30, 640.
Handle (see Hilt).
Hilt, 23, 25, 211/b.
Hit (see Touch, Cut).
Honesty, 28, 602, 605, 642.

Impartiality of judges, 55.
Incorrect fencing, 28, 605ff, 642ff.
Increase of a penalty, 621.
Indisposition, 51, 646.
Individual competitions, 522, 581.
Infighting, 33.
Initiation of touches, 32.
Injury, 22, 30, 51, 647.
In line, 231, 237, 418, 422.
Inquiry, 661.
Inspection equipment, 20ff.
Inspection of equipment, 17ff, 21, 708.
Insulation, electrical foil, 211/b, 721.
Interruption of fencing, 46, 48, 527.
Intervention of the Directoire Technique, 617.
Invalid touches, 230ff, 324ff, 411.
Investigation, 661.
Jacket, 27, 213, 315, 408.
Jacket, metallic or electrical (see Vest, metallic).
Judges, 53ff, 62ff, 68f.
Judging touches, 53ff, 61ff, 71ff, 227ff, 237ff, 322ff, 415ff, 422ff.
Jurisdiction, principles of, 614, 658.
Jury, 54ff, 56, 62, 227, 415, 512ff, 610.
Jury of Appeal, 506ff, 510, 613f, 618f.
Jury of honor, 613, 619.

Lamé (see Vest, metallic).
Lamps, 709, 715, 727.
Lamps, extension, 702, 709, 715.
Lamps indicating grounding, 727/4.
Lamps, pilot, 716, 727.
Leaving the strip, 32, 35, 38ff.
Length of the épée, 307.
Length of the foil, 206.
Length of the sabre, 404.
Length of the strip, 15, 41, 202, 302, 402.
License, judge's, 56.
Limit, lateral, 43.
Limit, rear, 39ff.
Limitation of valid surface, 220ff, 317, 410.

Line (see In line).
Line, center, 31, 203, 303, 403.
Line, on-guard, 31, 203, 303, 403.
Line, rear, 39ff, 203, 303, 403.
Line, warning, 37, 39ff, 203, 303, 403.
Localization of a defect, 231, 327.
Locking nut, 23.
Loss of ground, 36ff, 43, 623ff, 638.

Maintenance of order, 615.

Manner of fencing, 28, 30, 212, 316, 409, 605, 640ff, 645.
Manner of making touches (see Touch).
Martingale, 209, 309.
Mask, 27, 212, 218, 313, 408, 722.
Materiality of touches, 62, 64, 67, 68ff, 72, 228ff, 323ff, 415ff.
Mesh of masks, 27, 722.
Metallic strip (see Strip).
Metallic vest (see Vest).
Mounting (assembly) of weapons, 712.
Nationality of fencers, 525, 526 add., 542.
Neutrality of judges, 31, 57.
Neutralization (see Grounding).
Non-regulation equipment, 18, 21ff, 231, 326, 648.
Number of fencers in pools, 523, 541.
Number of fencers on teams, 565.
Number of touches, 45, 225, 319, 413, 562, 591, 597.
Nut, locking, 23.

Obedience, 602, 609, 657.
Obligation to apply the rules, 1.
Observance of the phrase d'armes, 233ff, 417ff.

Off-target (invalid surface), 221, 223, 411.
Offenses, 635ff.
Offenses against order, 654ff.
Offenses against sportsmanship, 648ff.
Offenses, competitive, 624ff, 637ff.
Offenses related to discipline, 657ff.
Offenses related to the field of play, 624ff, 638.

Offenses related to time, 639.
Offensive action, 10ff, 30, 32.
Official FIE competitions, 1, 17, 45, 56, 58f, 201, 227, 301, 304, 322, 501, 515, 517, 574, 579, 614, 622, 708, 715.
Olympic Games, 1, 505, 510, 592, 619, 634.

On-guard lines, 31, 203, 303, 403.
On guard, placement, 31, 37.
Operator for scoring machine, 60/a, 516/c.
Order of bouts, 526f, 530, 547, 554f, 561, 566.
Order of competitions, 588, 599.
Order of fencers, 526f, 550, 558.
Order, disturbing the maintenance of, 602f, 655.
Order in a fence-off, 530.
Orders of the Director, 31f.
Organization of competitions, 501ff, 522, 564ff, 571, 574.
Organization of supervision and inspection, 17ff, 503ff, 616ff.
Organizing Committee, 503, 613, 616, 634.

Padding in the guard, 23, 26, 712.
Pardon, 665.
Parry, 10, 233ff, 417ff.
Partiality of judges, 610, 652.
Passing the opponent, 35, 318 note.
Penalties, 623ff, 634.
Penalties, announcement of, 634.

- Penalties concerned with fencing, 624ff.
 Penalties, disciplinary, 628ff.
 Penalties, procedure, 658ff.
 Penalty, extension of, 617.
 Penalty of a touch, 615, 626.
 Penalty, remission of, 665.
 Penalty, suspension of, 615, 617, 623, 630.
 Personnel, auxiliary, 59ff, 204, 305, 516.
 Personnel, specialist, 60.
 Phrase d'armes, observance of, 233, 417.
 Pilot lamps, 716, 727.
 Piste (see Strip).
 Placement of fencers in pools, 534ff, 542, 543.
 Placement of Fencers—
 Standing (see classification).
 Placement of fencers on the strip, 31.
 Placement of the jury, 62f.
 Placement on guard, 31, 37.
 Plastron, metallic (see Vest, metallic).
 Plastron, protective (see Undergarment, protective).
 Pledge of honor, 55, 603.
 Plugs for connections, 217, 314, 702, 710, 717, 722, 730.
 Point (pointe d'arrêt), 26/E, 210f, 311f, 406, 719f, 732f.
 Pommel, 23f, 211/b, 721.
 Pool, 6.
 Président (de Jury) (see Director).
 President of the Jury of Appeal, 507.
 Pressure (strength) of point spring, 18, 71/2, 211, 311, 719, 732.
 Priority of the touch, 70, 75, 229, 232ff, 329ff, 416ff, 713, 724.
 Promotion to the next round, 529, 530, 538, 546.
 Protection of fencers, 27, 212ff, 315, 408.
 Protests, 511, 614, 659f.
 Prototypes of scoring machines, 704.
 Provoking the corps a corps, 224, 411, 641.
 Publication of penalties, 634, 648/7.
 Punctuality on the strip, 604, 654.
 Qualification of fencers, 529, 546.
 Qualification to the next round, 529, 530, 538, 546.
 Quillon (cross bar), 25.
 Readiness to fence, 604, 654.
 Rear limits, 39, 41.
 Rear line, 39ff, 203, 303, 403.
 Redoublement, 13, 237/1/c, 422/1/c.
 Reels, 214, 314, 702, 710, 717, 730.
 Refusal to award a touch, 30, 32, 38ff, 42, 230f, 237, 324ff, 422, 623, 625, 638ff, 645.
 Regaining ground, 39, 43.
 Registration of touches, 228ff, 323ff, 709, 713f, 724f.
 Regulations particular to a competition, 1, 2, 227, 649.
 Reliability of scoring machines, 714.
 Remise, 13, 237/1/c, 422/1/c.
 Remission of penalty, 665.
 Repairman, electrical equipment, 60/c, 516/c.
 Repetition of offense, 21, 664.
 Replacement of a fencer, 565, 569.
 Replacement on guard, 36, 37, 43, 226, 237/3, 320, 414/b, 422/3.
 Reprive, 663.
 Reprise (d'attaque), 13, 237/1/c, 422/1/c.
 Resistance in ohms, 710, 712/3, 714, 725.
 Respect for officials, 603.
 Responsibility for accidents, 16.
 Responsibility for equipment, 17.
 Rest period, fencer's, 519ff, 552, 559.
 Result established, 568.
 Resumption of the bout, 32, 231/a, 327/d.
 Retirement (see Withdrawal).
 Reversing positions (see Passing the opponent).
 Right of defense, 661.
 Right of way (see Priority and Validity of the touch).
 Riposte, 10ff, 234f, 419f.
 Riposte, delayed, 11, 237/1/c, 422/1/c.
 Riposte, immediate, touch by ["touche du tac-au-tac"], 35, 88, 42.
 Roll call of fencers, 53, 604, 654.
 Roughness, unnecessary (see Brutality).
 Sabre, 401ff.
 Safety measures, 16, 27, 212ff, 315, 408.
 Schedule, 519ff, 604, 654.
 Score board, 59, 516/a.
 Score sheets for a pool, 59, 516.
 Scoring equipment, electrical, 60, 204, 227, 228ff, 305, 322, 323ff, 701ff.
 Scoring equipment, electrical resistance, 701/5, 712/3, 714, 725.
 Scorekeepers, 59, 204, 305, 516/a.
 Scoring machine, 702, 709, 713ff, 723ff.
 Scoring machines, épée, 723ff.
 Scoring machines, foil, 713ff.
 Scoring machine, schematic diagram, 703.
 Scoring machine, table for, 204, 305.
 Scoring machine, timing, 713, 724.
 Scoring machines, prototypes, 704.
 Scoring machines, publicity by manufacturers, 705.
 Scoring machines, reliability, 714.
 Scoring machines, types of, 701.
 Security of connections, 217, 314, 710/4.
 Seeding, 524, 542, 550, 555, 575.
 Seeking the corps a corps, 224, 411, 641.
 Sensitivity of scoring machines, 714, 725.
 Shape of weapons, 22f.
 Side stepping (see Evasive actions).
 Simultaneous actions, 237, 422.
 Signals, lamp, 709, 713/2, 727.
 Signals, sound, 709, 713/3, 728.
 Sleeve, lining of, 212, 315, 408.
 Soldering materials, 231, 328, 711.
 Specialist personnel, 60, 516.
 Specifications of weapons, 22f, 205ff, 306ff, 404ff.
 Spectators, 204, 305, 612, 656.
 Spools (see Reels).
 Sportsmanship, 602, 648ff.
 Spring in the point button, 18, 71, 211, 311, 719, 732.

- Standing of fencers (see Classification).
 Stateless persons, 526 add/c.
 Stimulants (see Doping).
 Stop (stop hit), 12, 236ff, 421f, 527.
 Stretching device for metallic strip, 711.
 Strip, 15, 201ff, 301ff, 401ff.
 Strip, metallic, 15, 64, 201, 231/8, 304, 328, 702, 711.
 Substances, prohibited (see Doping).
 Substitutes, 569.
 Substitution of surface, 222.
 Supervision by the FIE, 504, 590, 593.
 Surface, invalid, 221, 223, 411.
 Surface, valid, 220f, 317, 410.
 Suspension of a decision, 614.
 Suspension of a penalty, 615, 617, 623, 630.
 Suspension, permanent ["radiation"], 617, 623, 631.
 Table for scoring machine, 204, 305.
 Table of classification of fencers, 525, 528, 542.
 Tables for direct elimination, 563 and pages 83, 84.
 Tables of indicators, pages 87-99.
 Tang of the weapon, 23.
 Target (valid surface), 220f, 317, 410.
 Team competitions, 564ff, 582.
 Team match, 5, 564, 567, 572, 578.
 Teams, composition of, 565.
 Technician, 611, 656.
 Temps perdu (riposte a) (see Riposte, delayed).
 Terminology, 3 to 13.
 Terrain (see Field of play).
 Tests of equipment, 71, 231, 327, 703ff, 708, 714/7.
 Tests of weapons, 18, 71, 231, 327.
 Threading blades, 720, 733.
 Throwing weapons, 25, 30.
 Thrusting weapons, 218, 316, 409.
 Thrusts, 218, 316, 409.
 Time allowed (accidents, indispositions), 50f.
 Time, broken, 11, 237/1/c, 422/1/c.
 Time, expiration of, 46, 49, 226, 321, 414.
 Time, fencing ["Temps d'escrime"], 9, 236f, 421f.
 Time hit, 12.
 Time in épée, 329f.
 Timekeeper, 45f, 59, 204, 305, 516.
 Touch, acknowledgement of, 66, 72, 606, 655.
 Touch, doubtful, 69/5, 74, 231/5, 327/i, 331, 422.
 Touch on the ground, 74, 201, 230, 304, 325.
 Touches, asked, offered, given, 607, 643f.
 Touches, double (see Double touches).
 Touches, invalid (see Invalid touches).
 Touches, manner of making, 28, 29, 30, 219, 316, 409, 605, 640, 645.
 Touches, number of, 45, 225, 319, 413, 562, 574, 591, 597.
 Tournament, 8, 502.
 Trainers, 611, 656.
 Trompement, 233/3, 237/2/b, 418/3, 422/2/b.
 Travel of the point, 18, 211, 311, 719, 732.
 Turning movements, 35.
 Turns, jumping, 35.
 Ultimate appeal, 614, 617f, 621.
 Unarmed arm, 30, 640.
 Undergarment, protective, 27/4, 212, 315, 408.
 Unplugging of connection, 327.
 Use of the electrical scoring machine, 229, 323.
 Use of the unarmed hand, 30, 640.
 Use, normal, of the weapon, 30, 33.
 Valid surface (target), 220f, 317, 410.
 Validity of the touch, 70, 75, 232ff, 329ff, 416ff, 713, 714.
 Vest, metallic, 216, 702, 722.
 Vindictive act, 28, 605, 645.
 Violent acts, 28, 605, 645.
 Voltage, 716, 729.
 Warning, at the warning line, 39, 41.
 Warning before a penalty, 615, 636ff.
 Warning line, 37, 39ff, 203, 303, 403.
 Warning of time remaining, 46.
 Weapons, electrical, 712, 718ff, 731ff.
 Weapons, general specifications, 22f.
 Weapons, manner of holding, 25, 30.
 Weapons, parts of, 23.
 Weapons required at the strip, 604.
 Weight of the épée, 306.
 Weight of the foil, 205.
 Weight of the sabre, 405.
 Weight, test, 18, 71, 719, 732.
 Width of the strip, 202, 302, 402.
 Withdrawal from a competition in progress, 532ff, 553, 654.
 Withdrawal of a fencer or team, 52, 532ff, 565, 569f.
 Withdrawal of a team, 533ff, 570.
 Withdrawal of a team member, 569.
 World Championships (and see Official FIE competitions), 579ff.
 World Under-20 Championships, 593ff.

CASTELLO

THE STANDARD FOR FENCING EQUIPMENT



CASTELLO FENCING EQUIPMENT CO., INC.

Since 1914

America's Oldest and Largest Importers and Manufacturers of Fencing Equipment.

836 Broadway • New York, N. Y. 10003 • (212) GR 3-6930

AFLA OPERATIONS MANUAL

| Table of Contents | Page |
|---|------|
| CHAPTER I—GENERAL | |
| 1. Authorized Competitions | iii |
| 2. Classification of Fencers | iii |
| 3. Ranking Fencers, Veterans | v |
| 4. Rating of Competitions | v |
| 5. Designation of Competitions | vi |
| 6. Schedule of Events | vi |
| 7. Eligibility of Individuals | vii |
| 8. Club Representation | vii |
| 9. Assumption of Risk | viii |
| CHAPTER II—MANAGEMENT AND CONTROL | |
| 1. Responsibility for Events | viii |
| 2. Organizing Committee | viii |
| 3. Bout Committee | viii |
| 4. Jury of Appeal | ix |
| 5. Juries | x |
| 6. Spectators | x |
| 7. Competitors Check List | x |
| CHAPTER III—ENTRIES | |
| 1. Filing and Fees | x |
| 2. Refunds | xi |
| 3. Denial of Entry | xi |
| 4. Team Events | xi |
| 5. Composite Teams | xi |
| CHAPTER IV—DISCIPLINE | |
| 1. Vindictive or Intentional Misconduct | xi |
| 2. Jury of Appeal | xii |
| CHAPTER V—SPECIAL RULES FOR NATIONAL CHAMPIONSHIP TOURNAMENT | |
| General | |
| 1. Nature of the Tournament | xii |
| 2. Date and Place of Tournament, Qualifying Competitions and Sectional Championships | xii |
| 3. Organization | xiii |
| 4. Financial Assistance | xiv |
| 5. Schedule of Events | xiv |
| Eligibility for the Tournament | |
| 6. Membership | xiv |
| 7. Automatic Individual Qualifiers | xiv |
| 8. Qualifying Competitions | xv |

| | |
|--|-------|
| 9. Number of Individual Qualifiers | xvi |
| 10. Number of Team Qualifiers | xviii |
| 11. Alternates | xviii |
| 12. Certification of Qualifiers and Alternates | xix |
| 13. Procedure of Entries | xix |
| 14. Composition of Teams | xix |
| Form of Competition | xix |
| 15. First Round | xx |
| 16. Subsequent Rounds | xx |

| | |
|--|-----|
| CHAPTER VI—THE LEAGUE | xx |
| 1. Jurisdiction and Affiliations | xxi |
| 2. Brief History | xxi |

| | |
|---|-------|
| CHAPTER VII—ADMINISTRATION OF NATIONAL AFFAIRS | xxii |
| 1. The Corporation | xxii |
| 2. The Board of Directors | xxii |
| 3. Committees of the Board | xxiii |
| 4. The National Nominating Committee | xxiii |
| 5. The U.S. Directors Commission | xxiv |
| 6. Official Publication | xxiv |
| 7. Promotional, Technical and Instructional Material | xxiv |
| 8. Trustees of Investment and Development Funds | xxv |
| 9. Geographical Organization | xxv |
| 10. Professional Certificate of Merit | xxv |

| | |
|--|--------|
| CHAPTER VIII—THE AMATEUR CODE AND RULES GOVERNING EXHIBITIONS | xxv |
| 1. Constitutional Definition | xxvi |
| 2. Precedents in the United States | xxvi |
| 3. International Precedents | xxvii |
| 4. Amateur Coaching | xxviii |
| 5. Status of Professional in Other Sports | xxviii |
| 6. Administration of Amateur Code | xxviii |
| 7. Rules Governing Exhibitions | xxviii |
| BY-LAWS OF THE AFLA, INC. | xxix |

The 1974 Operations Manual is a major revision of the 1970 edition. The process began with a review of the existing manual by a committee of the Board of Directors consisting of Ralph Zimmerman, Chairman, Tom Ahern, Tommy Angell, Irwin Bernstein, Joe Byrnes, Manny Forrest, and Emily Johnson. After recommendations on policy matters were acted upon by the Board of Directors, the final draft was prepared by Irwin Bernstein with the assistance of Emily Johnson and Ralph Zimmerman and was typed by Mrs. Liela Bernstein. The Board of Directors thanks all those who helped with this work.

CHAPTER 1—GENERAL

1. Authorized Competitions

A. Except as herein provided, competitive members of the AFLA may participate only in competitions scheduled by or under the auspices of the National Board of Directors or of the divisions and sections of the AFLA. Violations of this rule are punishable by disciplinary penalties according to the gravity of the offense.

B. Bouts between men and women are not permitted in formal competitions or exhibitions in which touches are counted.

C. Members of the AFLA are authorized to participate in collegiate and scholastic meets for which they are eligible, and in tournaments organized by the Intercollegiate Fencing Association, the National Collegiate Athletic Association, and similar intercollegiate and interscholastic associations, provided that such events are conducted under fencing rules that substantially conform to the rules of the AFLA.

D. Members of the AFLA are authorized to participate in foreign individual competitions when such events are organized by or under the sponsorship of a national federation that is a member of the FIE. Members are also authorized to compete in international collegiate or scholastic competitions which are held without any objections thereto by the federation of the country in which the event is held. Members of the AFLA who wish to participate in foreign or international competitions must be holders of FIE licenses and should be certified by the AFLA as to eligibility. Active, Life and Collegiate Members of the AFLA may obtain FIE licenses free of charge by applying to the Secretary of the AFLA. Other members must pay \$1.00. Members of the AFLA may not compete in foreign or international competitions as a team representing the U.S. except upon specific approval of the Board of Directors.

E. Amateurs may compete against professionals in all competitions, as long as the professional is a competitive member of the AFLA, except in those competitions specifically limited to amateurs only by the Board. No purse, however, may be awarded to either amateur or professional in any competition.

2. Classification of Fencers

For the purpose of providing reasonable equality of strength in competitions, fencers are classified nationally on the basis of competitive experience and achievement into the following categories: Class A (highest), Class B, Class C and Unclassified (lowest). The classification of a fencer in each weapon shall be changed immediately when he meets the conditions outlined herein below, and once he achieves a higher category he may not compete in a lower one unless there is a revision of these rules and, by definition applicable to all members, he falls into a new or lower classification. The following rules govern the classification of fencers:

A. A fencer is classified as Class A

(1) by winning an individual competition rated as Group 1 (see section 4, Rating of Competitions, below); or

(2) by being a finalist in the U.S. National Championships; or

(3) by being officially selected to represent the U.S. in the Olympic or Pan American Games; or

(4) by being officially selected to represent the U.S. in the World Championships and having achieved the round of 32 or better; or

(5) by being officially selected to represent the U.S. in the World Under-20 Championships and having achieved the round of 8 or better; or

(6) by being officially selected to represent the U.S. in the World University Games and having achieved the round of 16 or better; or

(7) by attaining distinction in another country as a competitive fencer which in the judgement of the Board of Directors is equivalent to that involved in the preceding clauses of this paragraph.

B. A fencer is classified as Class B

(1) by finishing second or third in an individual competition rated as Group I (see section 4 below); or

(2) by winning an individual competition rated as Group II (see section 4 below); or

(3) by competing as a member of a team that wins the U.S. National Team Championships; or

(4) by achieving first, second or third place in the Modern Pentathlon Epee event at the Olympic, Pan American or World Championships; or

(5) by being officially selected to represent the U.S. in the World Championships (excluding the World Under-20 Championships and the World University Games); or

(6) by being officially selected to represent the U.S. in the World Under-20 Championships and having achieved the round of 16 or better; or

(7) by attaining distinction in another country as a competitive fencer which in the judgement of the Board of Directors is equivalent to that involved in the preceding clauses of this paragraph.

C. A fencer is classified as Class C

(1) by being a finalist in an individual competition rated as Group I (see section 4 below); or

(2) by finishing second or third in an individual competition rated as Group II (see section 4 below); or

(3) by winning an individual competition rated as group III (see section 4 below); or

(4) by competing as member of a team that places second or third in the U.S. National Team Championships; or

(5) by having attained an A classification in another weapon.

D. A fencer is classified as XA by obtaining an A classification and thereafter failing for a period of seven years to achieve a fencing result which would have given him an A classification had he not previously been so classified. XA fencers will be classified with B fencers for the purpose of rating competitions.

E. For the purposes of classification, in rated competitions (see section 4 below), any placing attained by a professional will be awarded to the next ranking amateur.

F. A fencer remains unclassified as long as he does not qualify for Class A, Class B or Class C rating under the foregoing rules.

G. Except as specifically provided herein, the classification of a fencer in one weapon has no effect upon his classification in another weapon and is not affected by his winning or competing in individual three-weapon events, invitation meets, intercollegiate events, or unofficial club and interclub competitions.

H. Every member of the AFLA is personally responsible for ascertaining his own classification in each weapon. To avoid questions with respect to individual fencers, each division through its Executive Committee or other

designated officer or committee should certify the classification of all fencers in the division at the beginning of each fencing season. The Secretary of each division should send a certified list of Class A and Class B fencers in the division to the Secretary of the AFLA and the Editor of AMERICAN FENCING at the beginning of each season (August 1).

I. Whenever, at a competition, a question is raised concerning the classification of a fencer, the Bout Committee in charge shall decide the case, and such determination shall be conclusive for that competition. However, for subsequent competitions the decision shall be subject to review by the appropriate Executive Committee and by the National Board of Directors.

3. Ranking Fencers, Veterans

Two additional categories exist independently of the above classifications: Ranking Fencers and Veterans.

A. Ranking Fencers in a particular weapon are those who, based upon their standings in the most recent National Championship, have been selected by the Board as the strongest national competitors in that weapon. Such a classification will entitle that fencer to a seeded draw in individual competitions during the next succeeding fencing season.

B. Veterans are all fencers who (1) have attained the age of 50 years, or (2) have attained the age of 40 years and in addition have retired from all competitions except the Veteran's individual events or team events in which they participate as part of a team made up exclusively of veterans.

4. Rating of Competitions

A. In order to qualify as a Group I Competition, a competition must meet all of the following requirements:*

(1) There must be a minimum of 15 participants in the competition, at least six of whom must have a classification of Class C or higher.

(2) There must be at least two rounds.

(3) The final shall consist of no fewer than six fencers of whom no fewer than two must be Classified as Class A and two as Class B (or higher).

B. In order to qualify as a Group II Competition, a competition must meet all of the following requirements:

(1) There shall be a minimum of 15 participants in the competition.*

(2) There must be at least two rounds.

(3) The final shall consist of no fewer than six fencers of whom no fewer than two must be Class B fencers and two Class C (or higher).

NOTE: If all other requirements are met for A. or B. above, and the event is by direct elimination, the last 8 (or 6, if to a final of 6) shall be considered finalists for the purposes of these rules.

C. In order to qualify as a Group III competition, a competition must meet one of the following requirements:

(1) There must be no fewer than 12 participants in the competition and the final shall consist of no fewer than six fencers, at least two of whom must be class C (or higher), or

(2) There shall be a minimum of 18 participants.

D. Sectional and National Youth events may be rated as Group III if they meet one of the criteria in section C. above. In addition, every division is

* In determining the rating of a Sectional Championship, the divisional qualifying rounds shall be considered part of the event to establish the number of participants and those classified as Class C or higher.

authorized to schedule competitions restricted to fencers under or over a certain age, or to such unclassified fencers as are novices or relatively inexperienced; provided that if some unclassified fencers are barred from such events, an appropriate description of the basis of eligibility of contestants must be announced in the schedule. Such events may not be rated.

5. Designation of Competitions

A. An open competition is one in which all competitive members in good standing of the AFLA, and of the same sex, are eligible to compete without regard to their classification, rank, age, or divisional membership.

B. A closed competition is a sectional, interdivisional, or divisional competition in which eligibility is limited on the basis of sectional or divisional membership.

C. A restricted competition is one in which the eligibility of competitors is limited on the basis of classification, rank, age, academic status, or special invitation.

(1) A Class A competition is one open to Class A and Ranking fencers; it may be open to other members of the AFLA only to the extent noted in the schedule.

(2) The designation of a competition as Class B or Class C (or other designation) indicates the highest category of fencers permitted to participate therein, but these competitions are also open to fencers of lower categories unless the contrary is specifically announced in the schedule.

(3) Restricted competitions limited to fencers of a certain age or academic status shall not be further restricted on the basis of classification or rank unless organized and announced as invitational events.

D. The title "Championship" shall be limited to the most important competitions or tournaments in national, sectional, interdivisional or divisional schedules.

(1) National Championships include the individual open foil, epee, sabre and women's championships, and the corresponding team events. The Board of Directors reserves the right to designate other competitions as national championships, open or restricted.

(2) Sectional Championships include the Midwest, North Atlantic, Pacific Coast, Southeast, Southwest, Metropolitan, Mid-Atlantic and Rocky Mountain open interdivisional championships in all weapons. No restricted competitions shall be designated as sectional championships without the express approval of the Board of Directors. Sectional Championships must be held at least four weeks prior to the day of the opening event of the National Championship.

(3) Divisional Championships may be open or closed and shall be limited to one per weapon during any one year. No restricted competition shall be designated as a divisional championship without the express approval of the Board of Directors.

E. Academic contests, where the number of touches scored is not the sole criterion for victory in a bout, are permitted, provided adequate notice of the exact character of the event is included in the schedule.

6. Schedule of Events

The fencing season officially begins on August 1 and continues through July 31 of the next calendar year.

A. At the beginning of each season (and not later than October 1) each section and division through appropriate officers or committees, shall draft and publish a schedule of team and individual events.

B. The schedule shall indicate the name and address of the person to whom entries are to be forwarded and the closing date for entries. Unless otherwise announced in the schedule, entry fees will be refunded if notice of the withdrawal of a fencer is received not less than 72 hours before the competition is scheduled to start.

C. All foil and epee competitions shall be held with electrical equipment unless specifically identified as "non-electric" in the schedule.

D. The schedule should include the following information:

- (1) The title and classification of each event.
- (2) The date, hour and place.
- (3) The entry fee, method and conditions for entries.
- (4) The terms for admission of spectators, if any.
- (5) Any special regulations or conditions.

7. Eligibility of Individuals

A. Only competitive members of the AFLA in good standing are eligible to compete in team or individual events scheduled by or under the auspices of the AFLA, except by special invitation of the appropriate divisional or sectional officers or committees for events under their jurisdiction, or as restricted by the Board of Directors for the National Championships (see CHAPTER V, Eligibility for the Tournament).

B. No member of a division shall be in good standing unless his division is in good standing according to the established rules and practices of the AFLA. Consequently, if a member's division is not in good standing, the Board of Directors may transfer his membership to the National Division and make such rules respecting eligibility to enter competitions and for the holding of additional competitions as may be appropriate.

C. A fencer who has entered a competition but has failed to pay the required entry fee, and has either participated in the competition or failed to withdraw therefrom in time, shall be liable to the appropriate organizing committee of the AFLA for the amount of the entry fee and shall be ineligible to enter any subsequent AFLA competitions until restored to good standing by payment of the sum due.

D. Every entry certifies the entrant's eligibility for the particular event not only with respect to AFLA membership in good standing but also as to compliance with every other requirement.

8. Club Representation

The term "club" as used in these rules includes any organized fencing group of individual members. The group may be affiliated with a club, industrial institution, association or other entity. A recognized club is one which has a relatively stable organizational structure and membership, a place for regular fencing activity and preferably a professional fencing master for lessons and training.

A. A fencer may at any time resign from one club and join another, or join or hold membership in two or more clubs. However, within the same fencing season, no fencer may represent in competition more than one club without special permission of the Board of Directors. The fencer's first stated club affiliation at an AFLA competition in each fencing season will determine his club representation for that year.

B. A college or scholastic fencer, who is also a member of another recognized club, may represent his school in dual meets and other interscholastic or intercollegiate events, and also represent the other club in AFLA events. In addition, if the rules of his school conference require it, he may represent

his school in all AFLA individual events held during the school fencing season, while representing his club during the other portions of the AFLA year.

C. A fencer who, while a member of a recognized club, elects to fence unattached, may not be permitted to represent any club during the remainder of the season in individual competition, and may not compete in team events except as a member of composite teams.

9. Assumption of Risk

Every fencer engaging in competition, and every person attending a competition in any capacity whatsoever, does so at his own risk and peril and neither the organization having jurisdiction over the event nor the organization furnishing the place for the event, nor any officer, official, agent or employee of either of the aforementioned organizations, shall be liable in any manner for any damage, injury or loss suffered by any person as a competitor, official, attendant or spectator at a fencing event regardless of whether or not there has been compliance with the rules and regulations prescribed herein, and whether or not any official has waived or failed to enforce strict compliance therewith.

CHAPTER II—MANAGEMENT AND CONTROL

1. Responsibility for Events

A. National events (including the annual National Championship Tournament) are under the supervision of the President and the Board of Directors. (See Chapter V)

B. Sectional events are limited to the annual Sectional Championships and are under the supervision of the Section Chairmen and Executive Committees pursuant to Sectional by-laws. The Sectional Chairmen, after consultation with the Chairman or Executive Committee of the host division, appoint the Organizing Committee, the Bout Committee, and their respective Chairmen subject to the approval of the Sectional Executive Committees.

C. Divisional events are under the supervision of the Chairman and the Executive Committee or other appropriate committee of the division, pursuant to the divisional by-laws. The Chairman, with the approval of the appropriate divisional committee, appoints the Organizing Committee, the Bout Committee and their respective chairmen.

2. Organizing Committee

The organization of a competition or tournament is the responsibility of an Organizing Committee which shall provide the facilities, equipment and personnel indicated in Chapter V, Section 3, to the maximum extent possible, as well as any awards.

3. Bout Committee

Each Bout Committee, through its Chairman, is responsible for and in complete charge of all competitions within its jurisdiction, including all officials, contestants and spectators.

A. The Chairman

The Chairman is responsible for review of plans and programs set up by the Organizing Committee, the conduct of the competition, assignment of officials, seeding of pools, and maintenance of discipline.

B. Decision-making Procedure

The Bout Committee itself is not a parliamentary body which makes administrative decisions by majority vote. All of the committee's authority is vested in the Chairman who may delegate it as he sees fit. The Commit-

tee members are assistants who serve in an advisory capacity but cannot overrule the Chairman on administrative matters. Only on questions properly brought to it on appeal, does the Bout Committee decide by majority vote. In such cases, the Chairman has only one vote.

C. Requirements for Committee Membership

(1) The Bout Committee for AFLA events shall consist of members of the AFLA in good standing.

(2) The minimum requirement for a place on the Bout Committee is a thorough knowledge of the rules.

(3) Any member of the Bout Committee who is a competitor or team captain may not participate in the seeding of pools or direct elimination plan for the event in which he is involved.

D. Scope of Authority

The Bout Committee has no power to amend the rules of fencing. In emergency cases it may waive or modify the rules or organization for a particular event with the consent of the fencers directly or indirectly affected, but in all such cases a report of the action taken must be submitted to the appropriate governing body.

E. Appeal

The decisions of the Bout Committee on matters within its jurisdiction are final. However, if it ignores a positive prescription of the rules, or applies the rules incorrectly, a protest by the aggrieved person or team is allowed. If the protest is overruled by the Bout Committee, the aggrieved person or team may appeal, in writing, to the Jury of Appeal.

4. Jury of Appeal

The Jury of Appeal is responsible for hearing a protest against a decision of the Bout Committee or of a Director (where permitted under the Fencing Rules) which has been properly filed and overruled. Such an appeal to the Jury of Appeal must be in writing. Further, notice of appeal must be given to the Bout Committee.

A member of the Jury of Appeal may not act if he is personally involved or if by reason of his affiliation he is confronted with a potential conflict of interest; no proxy votes are permitted. The decisions of the Jury of Appeal are final. (For appeals from imposition of disciplinary penalties see Chapter IV, 2.)

A. Composition of the Jury of Appeal at a National Event

The Jury of Appeal at a national event shall be composed of all members of the Board of Directors present at the event, the Chairman or acting Chairman of the Bout Committee, and an officer from every division competing, not otherwise represented. In the latter case, if no officer is present, a member of the division shall be chosen by majority vote of the other members of the Jury of Appeal. The Chairman shall be the senior nationally elected officer present; if no national officer is present, a Chairman shall be elected by the Jury of Appeal from among its members. Each member of the Jury of Appeal, including the Chairman, shall cast one vote. In the event of a tie vote, the Chairman shall have an additional vote.

B. Composition of the Jury of Appeal at a Section Event

The Jury of Appeal at a Sectional competition shall be composed of all members of the Board of Directors and of the Sectional Executive Committee present at the event, the Chairman or acting Chairman of the Bout Committee, and an officer from every division competing and not otherwise represented. In the latter case, if no officer is present, a member of the

division shall be chosen by majority vote of the other members of the Jury of Appeal. The Chairman shall be the Section Chairman. In his absence, the Jury of Appeal shall elect a chairman from among its members. Each member of the Jury of Appeal, including the Chairman, shall cast one vote. In the event of a tie vote, the Chairman shall have an additional vote.

C. Composition of the Jury of Appeal at a Divisional Event

The Jury of Appeal at a divisional competition shall be composed of all members of the Board of Directors and of the divisional Executive Committee present at the event, the Chairman or acting Chairman of the Bout Committee, and the club or team captain of every club or team competing and not otherwise represented. In the latter case, if a captain is not present, a member of the club shall be chosen by majority vote of the other members of the jury of appeal. The chairman shall be the chairman of the division. In his absence, the Jury of Appeal shall elect a chairman from among its members. Each member of the Jury of Appeal, including the Chairman, shall cast one vote. In the event of any tie vote, the Chairman shall have an additional vote.

5. Juries

All members of the Jury shall be members of the League in good standing. A Jury may contain one or more professional members of the AFLA, if permitted by the Bout Committee for that event.

6. Spectators

"Spectators" include any and all persons attending a competition who are not at the moment engaged in active participation therein either as contestants, or any official capacity recognized by the rules.

Spectators are required, in the interest of safety and good order, to sit or stand at a distance of not less than ten feet from the limits of the strip and to obey any directives of the Director or the Bout Committee.

7. Competitors Check List

A. Associate members of the AFLA and members not in good standing are not eligible to compete.

B. It is the responsibility of the fencer to insure that his entry for a competition is filed in accordance with the Organizing Committee's regulations for that event.

C. Unless otherwise specified, all AFLA competitions are governed by the AFLA Rules and it is the responsibility of the fencer to familiarize himself with them.

D. It is the responsibility of the fencer to provide himself with the necessary equipment to compete in accordance with the Rules of the AFLA.

E. Unless otherwise provided, a fencer who violates any of the above directions is subject to appropriate disciplinary action.

CHAPTER III—ENTRIES

1. Filing and Fees

Unless otherwise specified in the schedule of events, team and individual entries shall be forwarded in writing to the Chairman of the appropriate Bout Committee at least one week in advance of the scheduled date for the event. The entry must be accompanied by the appropriate entry fee. Entries to the National Championships are subject to special regulations (Chapter V). National Championship entries must be submitted at least three weeks

prior to the opening of the event.

2. Refunds

Unless otherwise specified in the schedule of events, entry fees received in accordance with paragraph 1, above will be refunded if the Bout Committee receives notice of the withdrawal not less than 72 hours before the scheduled date for the event. (See special rules for National Championship.)

3. Denial of Entry

The Bout Committee shall reject any entry from a member who is not in good standing because of arrears in dues or entry fees, because of disciplinary penalties in effect, or otherwise.

4. Team Events

A. There shall be no limitation on the number of team entries from one club unless a specified limit is fixed in advance by the appropriate governing body.

B. Members of two or more teams representing the same club may not be interchanged during the competition (see exception for National Championships, Chapter V, Section 14.A.).

C. The names of individual fencers on the team need not be formally filed at the time the team entry is made, but should be given to the Bout Committee before the plan of competition is worked out.

D. No team entry shall be permitted to compete with a lesser number of members than required for the particular event (which shall be three unless otherwise announced in the schedule).

E. Every individual member of a team shall, by participating in the competition, personally certify his eligibility to compete.

5. Composite Teams

A. A composite team is one whose members do not represent the same club (they may all be unattached). Such teams are permitted unless notice to the contrary is included in the schedule of events. Further, a fencer may be part of a composite team in an event in which his club is formally represented with the approval of the appropriate division. Composite teams may compete hors concours in the National Championship qualifying round.

B. Composite teams must furnish a guarantee for the safe custody of any trophy which may be won.

C. The Bout Committee shall refuse the entry of any composite team when, in its judgement, the conditions of subsections A. and B. have not been complied with in every respect.

D. A fencer who is a member of a club may fence on a composite team without prejudice to his right to represent his club during the same season. (See Chapter I, Section 8.)

CHAPTER IV—DISCIPLINE

The principles set forth in the International Code of Discipline shall govern the imposition of disciplinary penalties in the U.S., with such modifications as may be necessary to conform to the structural organization of the AFLA and to any provisions contained in this chapter.

1. Vindictive Act or Intentional Misconduct

In the U.S., a fencer who commits a vindictive act, or who during infighting intentionally strikes his opponent, shall immediately be penalized one touch; and, upon repetition of the offense during any part of the com-

petition, shall be irrevocably excluded from the event without prejudice to further disciplinary action. The determination of whether a "vindictive act" has been committed or "intentional misconduct" has occurred lies within the discretion of the Director.

2. Jury of Appeal (See Chapter II, Section 4)

A. Appeal Procedure

If a protest against a decision of the Bout Committee or the Director (where permitted under the Fencing Rules) has been properly filed and has been overruled, an appeal may be taken to the Jury of Appeal for that competition. Notice of the appeal must be given to the Bout Committee.

B. Penalties

In case the penalty of exclusion or disqualification is inflicted during a competition upon an individual or team, the Jury of Appeal shall determine whether the penalty is for violation of a technical rule or for a serious breach of good order or a flagrant violation of the code of good sportsmanship. If the first, the penalty should not deprive an individual or team of any placement or prizes earned before the offense. If one of the latter, the penalty may include forfeiture of any placement or prizes earned during the competition. In all cases, the record of the action taken and the reason therefor must be filed with the Secretary for presentation to the National Board of Directors. In addition, the Jury of Appeal may recommend to the appropriate Executive Committee or the Board of Directors the imposition of more severe penalties, i.e., reprimand, suspension or expulsion from the AFLA.

CHAPTER V—SPECIAL RULES FOR THE NATIONAL CHAMPIONSHIP TOURNAMENT

GENERAL

1. Nature of the Tournament

The national championship competitions shall be announced annually in the divisional and national schedule of events and shall be held in two parts: First, a preliminary open qualifying competition (consisting of one or more rounds) which shall be held in each division for its AFLA members in good standing; Second, a subsequent championship competition limited to duly qualified contestants. The championship competitions shall constitute the National Championship Tournament and shall include open individual and team events in men's foil, epee, sabre, and women's foil and individual Under-19 events in men's foil, epee, sabre, and women's foil.

2. Date and Place of Tournament,

Qualifying Competitions and Sectional Championships

The date and place of the National Tournament shall be determined at or before the Annual Meeting of the Board of Directors in September of the second year preceding the event.

Bids for the Tournament shall be submitted to the Board of Directors by interested divisions at least 15 months in advance of the Annual Meeting of the Board held in September of the year preceding the event. Bids should include a full description of the facilities and personnel available and a plan for financing the necessary expenses of the Tournament. In the absence of divisional bids the Championships are automatically assigned to the Metropolitan Division.

The divisional qualifying rounds are to be held at least six weeks prior to the opening date of the National Championships. Sectional Championships are to be held at least four weeks prior to the opening date of the National Championships.

3. Organization

A. The Organizing Committee is responsible for providing all physical facilities, necessary equipment, supplies and personnel. The Chairman and additional members are appointed by the President of the AFLA after consultation with the Chairman and Executive Committee of the host division subject to the approval of the Board of Directors.

(1) The scene of the Tournament should be spacious, well-lighted and well-ventilated, with dressing rooms and showers for men and women. It should be within reasonable proximity to housing and eating facilities. Enclosed space with lock and key should be available for use by technicians and for storage. Adequate space for the Bout Committee should be close to and in sight of the fencing area. A closed room must be available for the Bout Committee deliberations. A public address system must be available.

(2) A minimum of ten regulation strips must be available for the Tournament. For electrical weapons there must also be a metallic covering for each strip, with masking tape or other means for fastening it to the floor; a minimum of 15 combination foil-epee, or 15 each of separate foil and epee indicators and batteries (or equivalent power source); not less than 40 reels and connecting cables so as to permit a double set of reels operating on each strip with spares; and interconnecting switches for each strip to switch the proper connecting cables to the indicators. Extension lights for each foil strip are required. Each strip must have a stop watch or stop clock as well as weights and travel gauges. There should be a public scoreboard for at least the final round.

(3) A Technician and assisting Technicians (6 to 8) shall be appointed by the Chairman of the Organizing Committee. The Organizing Committee shall provide the equipment and space for inspection and repair of weapons and machines. It should also provide for the sale of weapons and body cords to contestants whose personal armament breaks down during the competitions and cannot be repaired without undue delay.

(4) The Organizing Committee shall arrange for the attendance of an adequate number of trained personnel (Directors, judges, time keepers, scorers, etc.) to insure the proper and continuous conduct of the Tournament. It is also responsible for publicity, arrangements for Gala Night and publication of the program.

B. The Organizing Committee shall nominate and obtain the services of a full-time Press Officer whose sole function shall be activities related to publicity and press releases, and who shall prepare a summary of the events for AMERICAN FENCING.

C. The Bout Committee, subject only to the Jury of Appeal, has the ultimate authority for conducting the National Championships. It is in charge of all personnel, competitors, officials, and other persons present, including the audience. The Chairman and other members of the Bout Committee are appointed by the President of the AFLA after consulting with the Chairman and Executive Committee of the host division subject to approval of the Board. The Bout Committee shall be responsible for the assignment of directors and judges. In this they must follow the approved list of officials published by the Directors Commission. The Bout Committee must assign

the highest ranked directors before they assign lower ranked directors. (The rankings are "C", the highest, 3, 2, 1A, 1 lowest). Once assigned, directors may be reassigned or relieved at the discretion of the Bout Committee.

The elected National Officers of the League are automatically members of the National Bout Committee.

D. The Jury of Appeal at the National Championships shall be composed of all members of the Board of Directors present at the event, the Chairman or acting Chairman of the Bout Committee, and an officer from every division competing and not otherwise represented. In the latter case, if no officer is present, a member of the division shall be chosen by majority vote of the other members of the Jury of Appeal. The Chairman shall be the senior nationally elected officer present; if no national officer is present, a Chairman shall be elected by the Jury of Appeal from among its members. Each member, including the Chairman, shall cast one vote. In the event of a tie vote the Chairman shall also cast the deciding vote.

4. Financial Assistance

In order to assure the strongest possible representation from all sections of the country at the Tournament, the Board of Directors requires the host division to provide travel allowances under the following policies to individual open fencers:

A. No allowance is made to any competitor residing in the Section where the Tournament is held.

B. National champions are entitled to the cost of round trip transportation by air on scheduled airlines. They may not receive additional allowances under C. and D. below.

C. Fencers who placed second or third in the previous year's tournament shall receive travel allowances equal to ¾ round trip fare by air.

D. Fencers who placed fourth, fifth, or sixth in the previous year's tournament shall receive travel allowances equal to ½ round trip fare by air.

E. Individuals qualifying for 2 or 3 allowances under sections C. and D. above shall receive a total allowance equal to one full round trip fare by air.

F. Unused allowances detailed above may not be transferred to others.

G. No individual may receive more than a total of one full round trip fare by air from a combination of national, sectional and divisional sources, but may also receive specially earmarked contributions from other sources.

5. Schedule of Events

The exact schedule of events shall be prepared by the Organizing Committee in consultation with the Chairman of the Bout Committee and, when approved by the Board of Directors, shall be published in the official organ of the AFLA, AMERICAN FENCING.

ELIGIBILITY FOR THE TOURNAMENT

6. Membership

A. Only members in good standing at the time the entries for the National Championships are closed are entitled to compete in the National Championship Competition.

B. Entry to the individual events of the National Championship Competition is limited to qualified U.S. Citizens and permanent residents only.

7. Automatic Individual Qualifiers

A. The following members of the AFLA who are U.S. Citizens or permanent residents and in good standing are eligible to participate in the individual events of the Tournament without taking part in the qualifying competitions and without reducing the number of other qualifiers from the

division or the national division to which they belong.

(1) Finalists in each weapon of the immediately preceding National Championship are eligible to participate in the event in which they were finalists.

(2) Former national champions in each weapon.

(3) Members of the U.S. Olympic or Pan American Team, whichever team was selected most recently, provided, however, that such selection did not occur more than four years prior to the current Tournament, are eligible to participate in the weapon(s) in which they were selected for the team.

(4) Current Sectional champions in each weapon are eligible to participate in the weapon in which they won their championships.

(5) Not more than six members of the U.S. Pentathlon Squad in epee certified for the current year by the U.S. Modern Pentathlon Olympic Committee. The normal rules regarding club representation during the season are waived as to Pentathletes for the purpose of exercising this privilege in the Tournament.

B. A fencer competing in an official FIE Championship with the approval of the Board of Directors may be granted automatic qualification, at the discretion of the Board, if the qualifying competition for his division (including the National Division) was held at the time he was so engaged.

C. The privilege of automatic qualification for individual events in the Tournament may also be extended, at the discretion of the Board of Directors, to non-resident members of the AFLA who are U.S. Citizens.

D. The first six finalists of the National Under-19 Championships in the prior year are automatically qualified for the National Under-19 Championships provided they meet the requirements of age and residence and citizenship.

8. Qualifying Competitions

A. The divisional qualifying competitions shall be held at least six weeks prior to the date set for the opening of the Tournament and shall be open to all amateur members of the AFLA in good standing, who meet the requirements hereinafter set forth:

Unless otherwise provided by the division, only members of the division may compete in that division's qualifying competition. No amateur member of the division who is in good standing and files a proper entry shall be denied entry if he is eligible under Section 6 above.

B. In exceptional cases, subject to specific approval by the Board of Directors, a member of the AFLA in good standing may be permitted to qualify directly if he fulfills all of the following conditions; (1) that he earned qualification from his division the previous season, (2) that he was physically unable to compete in his current qualifying competition. No individual who has for the same season unsuccessfully attempted to qualify in a divisional qualifying competition shall be permitted to qualify by any other method.

C. In the event that the winner of a recognized inter-collegiate conference is unable to qualify from his AFLA division by virtue of a conflict between his collegiate schedule and his division qualifying round, he shall be eligible for automatic qualification as provided in the rules notwithstanding his failure to qualify in the preceding year.

D. Entries for the qualifying competition shall be timely sent to the Chairman of the Divisional Bout Committee or other person according to the divisional schedule.

E. All qualifying competitions shall conform strictly to the rules governing AFLA events and shall be held by the round-robin pool method with not less than three contestants qualifying from each pool to the subsequent round. Ties for qualification to succeeding rounds of the qualifying competition and to the championship competition shall be determined by the use of indicators.

F. Subject to the limitations in the preceding paragraph, each division at its discretion may designate its divisional championships as its qualifying competition.

G. In the event that the number of entries for a qualifying competition is less than the number of authorized qualifiers (see Sections 9 and 10 following), the qualifying competition need not be held and all entries shall be automatically qualified for the tournament.

H. Only members of the armed forces of the U.S. not regularly assigned to duty within the territory of an established division, and not members of the U.S. Modern Pentathlon squad, may qualify for individual events as representatives of the "Armed Forces at Large". In the event that the number of such entries is more than three, the National Bout Committee for the National Tournament shall schedule a preliminary competition to determine the qualifiers for the Tournament.

I. An aggrieved fencer may appeal from the local bout committee and/or the Jury of Appeal for qualifying competition any decisions involving a possible violation of the rules to the Board of Directors by forwarding said appeal to the National Secretary within three days after the qualifying round.

J. The qualifying competitions for the Under-19 Championships are open to all who have not reached their 19th birthday as of Jan. 1 of the year in which the final rounds of the Championships are held.

(1) Each Section is required to set up divisional qualifying criteria in the manner of the regular Sectional Championship.

(2) Each Section shall conduct an Under-19 qualifying tournament to determine qualifiers and alternates in each weapon.

K. Each division is required to hold an AFLA Junior Olympic qualifying tournament to determine qualifiers and alternates in the Under-20 (open to all who have not reached their 20th birthday as of Jan. 1 of the year in which the final rounds of the championships are held) and Under-16 (open to all who have not reached their 16th birthday as of Jan. 1 of the year in which the final rounds of the championships are held) categories.

L. Divisions may combine Under-19, Under-20, and Under-16 qualifying events providing arrangements are made to determine qualifiers and alternates in order for each of the three categories.

9. Number of Individual Qualifiers

A. In all the qualifying competitions for the National Individual Championships, the number of qualifiers who will be eligible to compete in the Tournament from each division shall be determined by the number of eligible contestants competing for qualification. Not included in the number of eligible contestants are those who, though fencing in the qualifying competition, (1) qualify automatically, or (2) are not members of the division or, (3) are not themselves eligible to fence in the National Tournament.

B. The minimum number of qualifiers from a division shall be three if eight or fewer eligible contestants compete in the qualifying competition.

C. Additional qualifiers shall be permitted if nine or more eligible con-

testants compete in the qualifying competition, as follows: 9-12 inclusive, one additional qualifier; 13-15 inclusive, two additional qualifiers; 16-18 inclusive, three additional qualifiers; 19-21 inclusive, four additional qualifiers; 22-24 inclusive, five additional qualifiers; 25-36 inclusive, six additional qualifiers; and one more additional qualifier for each ten eligible competitors in excess of 36 (e.g., 37-46, 7 additional; 47-56, 8 additional; etc.)

D. Notwithstanding the limitations set forth above, the host division shall be allowed to qualify double the number it would normally be allowed with a minimum of ten for each individual event, in addition to automatic qualifiers.

E. Each Section shall qualify members in each weapon to the Under-19 Championships as follows:

(1) Automatic qualification; Medalists of the previous National Under-19 Championships shall qualify automatically provided they still meet the requirement of age.

(2) Qualification from Sections: Each Section shall be entitled to a minimum of three and a maximum of six, determined by the number of eligible fencers in the Section Under-19 Qualifying Championships in each weapon, as follows: less than 20 = 3 qualifiers; 21-25 = 4 qualifiers; 26-30 = 5 qualifiers; 31 or more = 6 qualifiers. Automatic qualifiers who fence in the Section Championships shall not be counted as "eligible fencers."

(3) By appeal: A fencer may petition the National Executive Committee for permission to fence in the Under-19 Nationals if he fulfills ALL of the following conditions:

a. That he qualified for the Under-19 Section Championships the year in question through the Division qualifying rounds.

b. That he was physically unable to compete in the Section Under-19 Qualifying Championships, and he furnishes written evidence of the fact. (Mere attendance at an out-of-town school during the championships shall not be considered as physical inability to compete.)

c. That he has done at least one of the following:

i) Competed in the Under-19 Section Championships the previous year and reached the final round.

ii) Competed in the Under-19 Nationals in the past year.

iii) Competed in the Senior Nationals the past year and reached the second round.

iv) Qualified for the Senior National Championships for the current year.

d. That he makes his petition in writing to the AFLA National Secretary, with a copy to the Section Chairman no later than one week prior to the National entry deadline.

If a fencer is permitted to enter under the appeal procedure, his entry shall not in any way affect the number of qualifiers from the section qualifying round.

F. Each division shall qualify members in each weapon to the Under-20 AFLA Junior Olympic Championships as follows:

(1) Automatic qualification: The first six finalists of the previous National Under-19 and the AFLA Junior Olympic Championships and members of prior year's Under-20 Team shall qualify automatically provided they still meet the requirement of age.

(2) Qualification from division: Each division shall be entitled to a mini-

num of two and a maximum of five, determined by the number of eligible fencers in the divisional Under-20 qualifying event in each weapon as follows: less than 12 = 2 qualifiers; 12-20 = 3 qualifiers; 21-30 = 4 qualifiers; 31 or more = 5 qualifiers.

(3) The host division shall be entitled to double the number of qualifiers it would normally be allowed.

(4) Automatic qualifiers do not count in the calculations involved in (2) and (3) above.

G. Each division shall qualify two members in each weapon to the Under-16 AFLA Junior Olympic Championships.

10. Number of Team Qualifiers

A. Each division may qualify a maximum of three teams for each team event in the Tournament. The U.S. Modern Pentathlon squad and the three branches of the armed forces (Army, Air Force, Navy) may each enter one team in each event. The normal rules regarding club requirements during the season are waived as to Pentathletes and service personnel for purposes of exercising this privilege in the Tournament.

B. Teams shall represent a recognized U.S. club and no club may qualify more than one team even though the rules of the qualifying competition may permit a club to enter two or more teams.

C. Composite teams are forbidden in the Tournament.

D. Only teams located within the territorial limits of the division shall qualify from that division.

E. Composite teams may enter the qualifying rounds but must compete hors concours.

11. Alternates

A. In addition to the regular qualifiers provided in the preceding rules, each division may determine a number of alternates who shall, in a specified order, become eligible for the Tournament in the event of the failure to enter of a regularly qualified individual or team. The number of such alternates shall be equal to the number of non-automatic qualifiers from the division. It is permissible for secretaries, if they determine at the time of the qualifying competition, that the person definitely will not go to the National Championships, to bypass this person's name and take the next qualified alternate. Once the list has been properly submitted, no substitutions may be made.

B. No individual may be an alternate unless he has actually participated in the qualifying competition.

12. Certification of Qualifiers and Alternates

A. Immediately upon the completion of the qualifying competition in each weapon, the Secretary of each division shall transmit to the Secretary of the League the following information:

(1) A certified list of the number of eligible fencers taking part in each qualifying competition, the number of automatic qualifiers in each weapon in the division, and the total number of fencers in each qualifying event.

(2) A certified list of the qualifiers from that division (including automatic qualifiers who are members of that division) in order of their placement in the qualifying event.

(3) A certified list of alternates in each weapon, in order of placement in the qualifying event.

(4) A certified list of the teams authorized to represent the division, and any alternates.

B. This information must reach the Secretary of the League at least four weeks prior to the date set for the opening of the Tournament, and does not constitute the required entry for the Tournament. Failure to provide such certified lists may lead to the disqualification of competitors from that division.

C. The Sectional secretaries must submit the list of Sectional Champions, finalists and Under-19 qualifiers to the National Secretary four weeks prior to the opening of the National Championship.

D. The Secretary of the League shall check the certified lists against the list of AFLA members in good standing and shall forward the lists, with his endorsement, or corrections, to the Chairman of the National Bout Committee for his guidance.

ENTRIES

13. Procedure for Entries

A. Every individual or team qualifier, including every automatic qualifier and every alternate, who wishes to participate in the championship competitions of the Tournament must file an official entry with the Chairman of the National Bout Committee (or the person designated in the schedule for the Tournament), at least three weeks in advance of the date set for the opening of the Tournament.

B. Every entry must be accompanied by the required entry fee and a stamped self-addressed envelope. All fees are determined by the Board of Directors and shall be announced in the schedule for the Tournament.

C. Within one week after the closing date for entries, the Chairman of the Bout Committee shall check the entries received against the certified list of qualifiers and alternates which has the endorsement of the Secretary of the AFLA. He shall determine the number eligible to qualify from each division, the number of valid entries actually on hand from the division, and shall return the entries and fees to those alternates who are in excess of the permissible number for the division. No entry fees will be refunded for withdrawals thereafter and no substitutions shall be permitted.

D. The Chairman of the Bout Committee shall inform every entrant of his acceptance for the Tournament and shall forward a complete list of accepted entries and the collected fees to the Chairman of the Organizing Committee not less than ten days prior to the Tournament.

14. Composition of Teams

A. A duly qualified and entered team need not limit its composition to those members of the club who actually competed on that team in the qualifying competition and the general rule providing that members of two or more teams representing the same club may not be interchanged during a competition (applicable in the qualifying competition) shall not apply.

B. No fencer shall be permitted to represent a club in the team championship competition unless he is a bona fide member and represented that club at least once during that regular season in a competition held by the division where the club is located.

FORM OF COMPETITION

15. First Round

A. The first round of the championship competitions, team and individual, shall be held by the pool method, but byes may be given without limitation of number at the discretion of the Bout Committee according to a formula of general application.

B. The seeded draw in the first round of the championship competitions

shall be governed first by the list of National Ranking fencers and fencers of International Rating and next according to the judgement of the Bout Committee aided by the statements of estimated strength contained in the certifications filed by divisional secretaries. However, members of the same division shall, insofar as possible, be separated, in the same manner as required for members of the same club.

16. Subsequent Rounds

A. Unless otherwise specifically announced in the schedule, at least three fencers shall qualify from each elimination round in individual events, and the final round-robin shall consist of at least six fencers. Ties for qualifications shall be determined by the use of indicators in all rounds of the Tournament.

B. In the event that a "super-final" of only two fencers is scheduled, the championship shall be decided either on the basis of a ten-touch bout in men's events and an eight-touch bout for women with a two-touch advantage (up to a maximum of 12 and 10 respectively) required for victory, or on the basis of individual matches for two out of three bouts (5 touches in men's events, 4 touches for women).

C. If the schedule announces that the final of an individual championship is to be held by direct elimination, it shall state whether the top sixteen or top eight competitors will participate in the direct elimination and the type of bouts or matches to be fenced.

D. In team events, after the first round, the competition may proceed, at the discretion of the Bout Committee, by the pool method or by direct elimination, or a combination of both, to produce a final of two, three, or four teams.

E. Fencers who have been eliminated are required to report to the Bout Committee for assignment as officials in the subsequent round. Failure to report will make the individual subject to disciplinary action, which may include exclusion from subsequent National Championships.

CHAPTER VI—THE LEAGUE

1. Jurisdiction and Affiliations

The Amateur Fencers League of America, Inc. (AFLA) is the official governing body for amateur fencing in the United States and its exclusive jurisdiction is recognized by the Federation Internationale d'Escrime (FIE), the U.S. Olympic Committee (USOC), the Amateur Athletic Union (AAU) and other organizations.

The AFLA is the sole representative of U.S. amateur fencing in the FIE, the governing body for all official international fencing competitions including the World and Olympic Fencing Championships. Any U.S. fencer wishing to participate in official international contests must be accredited to the FIE or to the host country as to amateur standing and qualification by the AFLA.

The AFLA is a member of the USOC, and its representatives serve on the Board of Directors of the USOC. The League works in close cooperation with the USOC in the selection and training of U.S. Olympic Fencing Teams through its majority membership on the Olympic Fencing Sports Committee. Every member of the U.S. Olympic Fencing Team must be a member of the AFLA.

Through articles of alliance signed in 1905, the AAU recognizes the

individual winners of AFLA national championships as the official amateur fencing champions of the United States. The AAU also respects and enforces all penalties of suspension and disqualification imposed by the AFLA.

The AFLA maintains close relations with the National Fencing Coaches Association of America (NFCAA), the National Collegiate Athletic Association (NCAA), the Intercollegiate Fencing Association (IFA), the National Intercollegiate Women's Fencing Association (NIWFA), and several regional intercollegiate associations, whose respective jurisdiction of fencers in their member colleges is explicitly recognized. Most of the active fencing teachers in the U.S. are Associate Members of the AFLA and enjoy voting privileges.

2. Brief History

A. Foundation and Officers

The AFLA was founded in New York City on April 22, 1891. Prior to that date fencing events had been conducted by the AAU. The organizers elected Dr. Graeme M. Hammond as the first President and he held that office from 1891 to 1925. The office has been held successively by Col. Henry Breckinridge, F. Barnard O'Connor, Leon M. Schoonmaker, Harold Van Buskirk, John R. Huffman, Dernelle Every, Miguel de Capriles, Jose de Capriles, Donald S. Thompson, Dr. Paul T. Makler, Norman Lewis, Alan Miles Ruben and Stephen B. Sobel, the present incumbent.

The office of Secretary has been held successively by W. Scott O'Connor (1891-1925), F. Barnard O'Connor, Leon M. Schoonmaker, J. Howard Hanway, Dernelle Every, John R. Huffman, Ervin S. Acel, Warren A. Dow, Dernelle Every, Ralph M. Goldstein, Allan S. Kwartler, Anthony J. Orsi, William J. Latzko and Irwin F. Bernstein, the present incumbent.

The office of Treasurer was discharged by the Secretary prior to 1936. Since then the Treasurers have been J. Howard Hanway, George Cochrane, Robert S. Driscoll, Rudolph Ozol, Leo Sobel and Peter Tishman, the present Treasurer.

The office of Foreign Secretary was an elective position from 1951 to 1968, when it was discontinued. Tracy Jaeckel, Gen. J. V. Grombach, Ralph M. Goldstein, Laszlo Pongo, Norman Lewis and George V. Worth held the position. It was reinstated as an appointive position effective September 1, 1973.

In 1968 the new office of Executive Vice President was authorized. Norman Lewis was the first to serve in this capacity. It is now held by William A. Goering.

In 1973 the new offices of two National Vice-Presidents were authorized. Emily B. Johnson and Chaba M. Pallaghy are the present incumbents.

B. International Activity

Under the leadership of the AFLA, United States fencers have achieved considerable prestige on and off the strip. Despite financial and geographical handicaps to participation in most major international competitions, U.S. fencers have competed with distinction in international events since 1904. The record of the Pan American Games has established the supremacy of U.S. fencing in the Western Hemisphere.

In 1953 the AFLA was host to the World Championships in Philadelphia. The event attracted 22 nations, and 203 different individuals competed. Started in 1961, the annual Martini-Rossi International Tournament in New York has become a premier international event that brings many of the ranking world fencers to the United States. In 1971 the AFLA was host to the

World Under-20 Championships in South Bend, Indiana.

Two fencers have served on the International Olympic Committee (IOC). The first was Frederick R. Coudert of New York, who was succeeded in 1952 by J. Brooks Parker of Philadelphia.

The highest honor and vote of confidence in U.S. fencing was bestowed by the FIE in 1960, when it elected Miguel de Capriles as President for a four-year term and entrusted the running of international fencing affairs to an all U.S. Bureau including Jose de Capriles, Deputy President; Gen. J. V. Grombach, Secretary-General; and Leo G. Nunes, Treasurer.

The honor of taking the Olympic oath at the opening ceremony on behalf of all the assembled athletes was given to Lt. George C. Calnan in the 1932 Olympiad and to George V. Worth in the 1959 Pan American Games. The honor of carrying the flag for the U.S. delegation as it entered the stadium was awarded to Norman C. Armitage in the 1952 and 1956 Olympic Games and to Miguel de Capriles in the 1951 Pan American Games. In the 1968 Olympic Games, Mrs. Janice Romary became the first woman ever to carry the flag of the U.S. delegation, this signal honor recognizing her sixth competitive appearance in the Olympic Games.

CHAPTER VII—ADMINISTRATION OF NATIONAL AFFAIRS

1. *The Corporation*

The AFLA is a non-profit corporation under the laws of the Commonwealth of Pennsylvania, governed by annually elected representatives of the individual members. The classes of membership are defined in the By-Laws. The Internal Revenue Service has recognized the League as a tax-exempt organization, and all contributions qualify as charitable deductions for the donor. Information about such contributions may be obtained from the National Secretary.

2. *The Board of Directors*

The Board of Directors, which is the final authority on all fencing questions in the United States, consists of the national officers, the Chairman of each Division and Section and a number of "Additional Directors" from the divisions fixed each year on the basis of the number of members in each division, and the President of the National Fencing Coaches Association of America (NFCAA).

All national officers are elected at the Annual Meeting of the AFLA held at the site of and during the National Championship Tournament, in even numbered years.

3. *Committees of the Board*

In carrying out its functions, the Board of Directors relies heavily upon the work of certain standing committees and a few special committees. The committees are nominated by the President and elected by the board. Among the standing committees are:

A. *Executive Committee*, consisting of the President, the Executive Vice-President, the additional Vice-Presidents, the Secretary and no fewer than two other Directors, which acts for the Board during the period between regular meetings.

B. *Policy Board on AMERICAN FENCING* which consists of the President, Secretary, and Treasurer of the AFLA, and the Publisher and Editor of the magazine. All questions of policy affecting the publication of AMER-

ICAN FENCING are referred for decision to this Policy Board.

C. *Junior Olympic Development Committee*—which, under standards developed by the Board of Directors, reviews requests from divisions for funds and authorizes disbursements for development activities. It also distributes information on how to organize Junior Olympic Development Programs and otherwise assist in the build-up throughout the country of this most important AFLA activity.

D. *Law Committee*—which, under the supervision of the League Counsel who serves as its Chairman, handles all legal matters affecting the League. It also advises on the interpretation of the Amateur Code.

E. *Reinstatement Committee* which reviews and investigates all applications for reinstatement to amateur status and makes recommendations to the Board. No applications are processed unless two years have elapsed since the last act of professionalism.

F. *Certificate of Merit Committee* which reviews properly submitted material pertaining to this honorary award and recommends to the Board when appropriate.

4. *The National Nominating Committee*

The National Nominating Committee is elected by the membership at the Annual Meeting of the AFLA held in odd numbered years. It must consist of voting members who come from at least 5 different divisions. The recent practice has been to select committee members representing several different sections.

The function of the committee is to select candidates for national office and present a slate to the Secretary of the AFLA before February 1st. The committee is so composed that it is expected the members will sound out sentiment in their respective Sections and submit names which meet with general approval.

Every national officer is elected for a two year term and there are no restrictions as to the number of terms in the By-Laws. The recent practice has been for the President to serve for four years.

5. *The U. S. Commission on Fencing Rules and Officials*

The commission is composed of all AFLA members who hold a valid FIE officials license, plus other appointed members of the AFLA. It functions through its Executive Committee which has responsibility for developing and assigning U.S. international officials, preparation of clinic formats, examination development, rules legislation and interpretation, the conducting of hearings on matters referred by the Board of Directors, the administration of examinations for Class 2 and 3 ratings, and liaison with schools and colleges.

Five classes of officials are recognized by this commission: 1. 1A, 2, 3, and C (FIE license). Classes 1 and 1A are awarded at the divisional level, and indicate that the holder is qualified to officiate at the preliminary and final levels, respectively, of divisional competitions. Class 2 rating is awarded by the Sectional Executive Committee after recommendation by the division and an examination by higher rated officials. The Class 2 official is qualified to officiate through the finals of the Sectional Championships, as well as any lower ranked competition. The highest domestic rating, Class 3, is awarded only by the Commission itself, after examination by at least three ranking officials and at least one Commission member. The Class 3 official is qualified to direct at any level of competition in the U.S., including the finals of the National Championships. Divisions may develop their own

criteria for awarding Classes 1 and 1A, but should require at least one full season of successful officiating activity prior to receiving each designation.

The U.S. Directors Commission publishes periodically a list of Class 2, 3 and C officials, and is responsible for maintaining the quality of this list. In any Group I competition, it is mandatory that the highest-classified available officials be used, except they may be relieved by the Bout Committee as required to avoid overwork. The Commission is the sole authority for requests to the FIE for examination as an International Director.

U.S. fencers have served with distinction as president of jury in the finals of Olympic and World Championships: M. de Capriles (1936, 1952, 1958), J. de Capriles (1952, 1956), Dr. Daniel Bukantz (1958, 1960, 1964, 1967), Ralph M. Goldstein (1958, 1960), Allan S. Kwartler (1960), George V. Worth (1960, 1963) and Chaba M. Pallaghy (1968, 1972). An all-U.S. jury served throughout the 1956 sabre final, consisting of Jose de Capriles, Dr. Bukantz, R. Richard Dyer, Mr. Kwartler and Mr. Worth. The following U.S. fencers have served on the Bout Committee in charge of Olympic Championships: Tracy Jaekel, M. de Capriles, J. de Capriles, and Curtis C. Ettinger.

6. Official Publication

In order to promote better communication among fencers throughout the United States, the AFLA in 1949 designated the magazine AMERICAN FENCING as the official publication of the AFLA. AMERICAN FENCING was founded by Jose de Capriles and William L. Osborn who served as Editor and Publisher respectively and without remuneration. Upon Mr. de Capriles' death in 1969, Ralph M. Goldstein was appointed as Editor. The magazine is distributed to all members of the AFLA six times a year as part of their membership, and is often used to make official announcements to the League members. Subscriptions also circulate throughout the fencing world.

Persons having articles they wish printed in the magazine should send them to the Editor as listed in AMERICAN FENCING.

7. Promotional, Technical and Instructional Materials Available

The following list of material is presently available (November 1973) to any interested fencer. Apply to:

- | | |
|---------------------------------------|------------------------------------|
| The Secretary | |
| Amateur Fencers League of America | |
| 249 Eton Place, Westfield, N.J. 07090 | |
| A. AFLA Membership Application | I. Direction and Judging— |
| B. How to Understand and Enjoy | Questions and Answers |
| the Sport of Fencing | J. Junior Olympic Fencing |
| C. Questions and Answers About | Brochure |
| the AFLA | K. Junior Olympic Publicity Poster |
| D. Fencing Bibliography | L. AFLA Pin |
| E. Fencing Films and Visual Aids | M. AFLA Patch |
| F. How to Organize a Fencing | N. AFLA Decal |
| Program | O. Classification Patch |
| G. How to Organize a Fencing | P. Nationals Patch |
| Workshop | Q. Score Sheets |
| H. AFLA Fund Raising Brochure | R. Rules Book |

8. Trustees of Investment & Development Funds

The President of the AFLA and two other individuals who may not be officers of the League serve as managers of two investment accounts look-

ing towards the long term development of AFLA activities. One fund is earmarked for domestic development programs and the other is dedicated to improving our international efforts. While the investment income of each account is available for current activities, the principal and any additions thereto can not be expended until the account reaches \$100,000. or has been in existence for at least fifteen (15) years.

9. Geographical Organization

At first, membership in the AFLA was heavily concentrated in Metropolitan New York, although divisions were created to administer the local affairs of fencing groups in other parts of the country. The first divisions were established on March 20, 1892 in Nebraska and New England. In 1973 there were over 50 active divisions as well as a National group composed of members who do not belong to an active division.

Non-administrative regional units, called Sections, were created for the purpose of conducting annual regional championships among divisions within a section. The first sectional championship was organized on the Pacific Coast in 1925, and has been held annually ever since.

By 1973 there were 8 sections whose names indicate their general boundaries: North Atlantic, Metropolitan, Mid-Atlantic, Southeast, Midwest, Rocky Mountain, Southwest, and Pacific Coast.

For further information regarding the boundaries of Divisions and Sections, please contact the Secretary, AFLA or the Chairman of the Division or Section concerned.

10. Professional Certificate of Merit

The Professional Certificate of Merit is an honorary award voted by the Board of Directors to professional teachers of fencing who have rendered distinguished service to the AFLA by developing among their students the qualities of technical skill and love of fencing, as well as the spirit of sportsmanship. This award does not purport to certify the professional competence of fencing instructors, but the AFLA believes that outstanding instructors are deserving of recognition by the national governing body for fencing in the United States.

The Professional Certificate of Merit is never voluntarily offered by the Board of Directors and it cannot be solicited by a teacher of fencing. A proposal for the award must be made by two or more members of the Board, or by the Executive Committee of a division, in the form of a letter to the Board accompanied by the fencing history of the professional to be honored and the names and achievements in AFLA competition of at least two of his recognized pupils. The submitted material is then reviewed by the Certificate of Merit Committee which reports to the Board of Directors its findings and recommendations.

CHAPTER VIII—THE AMATEUR CODE AND RULES GOVERNING EXHIBITIONS

1. Constitutional Definition

The By-Laws of the AFLA (Article VII, Section 11) contain the following definition:

"An amateur fencer is one who participates in fencing solely for the love of the sport, who has not derived direct or indirect financial benefits from competition or exhibitions in fencing, and who has never been a professional teacher of fencing or professional

competitor or trainer in any branch of athletics."

The By-Laws also give the Board of Directors the exclusive power to enact, interpret and apply the Amateur Code. The Board is guided in its interpretations and decisions by its own precedents and those of the AAU and the FIE.

2. *Precedents in the United States*

A. Under the precedents of the AFLA, there is no objection to the receipt of compensation by an amateur fencer for writing, editing or publishing news reports, articles, magazines, or books on fencing; or for weapon or equipment repair, or manufacture; the guiding principle in these cases being that the fencer is capitalizing upon his skill as an author, designer, speaker or electrical technician, rather than upon his skill or reputation as a fencer. Compensation received as an official at collegiate fencing meets must not substantially exceed actual out-of-pocket expenses incurred in connection therewith and must conform to a basic plan of general application that has been approved by the Board of Directors. The policies of the AFLA with respect to fencing exhibitions are stated in a separate portion of this chapter.

B. Under the precedents of the AAU, the following acts are forbidden:

(1) Participation in any competition not held under the rules and sanction of the AFLA.

(2) Obtaining any financial benefits, directly or indirectly, from participation in any competition or exhibition in any sport. This includes the sale of personal prizes, receipt of excessive travel expenses, and any other financial benefits.

(3) Participation in a competition or exhibition against or with persons ineligible to compete as amateurs, without having first obtained permission to do so from the Board of Directors or from an authorized representative of the Board.

(4) Participation in any sport under an assumed name, unless duly approved in advance by the proper governing body; or commission of fraud or of grossly unsportsmanlike conduct in connection with participation in any athletic sport.

3. *International Precedents*

The FIE Statutes report the following precedents:

A. An amateur may participate in mixed competitions (with or against professionals) provided that such competitions are authorized by their national federation; he may not compete in an event organized by a professional group (1931 Congress).

B. An amateur has the right to receive in cash, as a maximum, the reimbursement of his actual expenses in participating in a competition. But such reimbursement cannot be contingent upon the final standing of such a fencer in the competition (1949 Congress). Reimbursable expenses may include: (1) transportation costs; (2) the cost of lodging and meals; (3) pocket money in a moderate amount (1956 Congress).

C. An amateur does not have the right: (1) to bet upon the competitions in which he takes part; (2) to sell or pledge prizes won in competition; (3) to participate in competitions under an assumed name without the authorization of his national federation; (4) to participate in competitions for money; (5) to lend his name to any kind of commercial advertisement; (6) to accept cash prizes in competition; (7) to accept reimbursement for participation expenses in international tournaments for a period longer than 30 days per year, travel time excluded; (8) to accept reimbursement of the

expenses of persons accompanying him to a competition; (9) to accept, under any form whatsoever, any indemnification for loss of earnings or loss of employment time. However, this prohibition does not include vacations under the normal conditions of his profession, or vacations granted under similar conditions on the occasion of the Olympic Games (and provided they do not constitute in a round-about fashion a reimbursement, direct or indirect, of lost salary), or the payment in hardship and exceptional cases, after due inquiry in each instance and in the form of a disbursement made directly by the employer, of an indemnity to the wife or mother of an athlete who is the sole support of his family (10C, 35th Session, 1938); (10) to accept any remuneration to shift his affiliation from one club to another or to remain a member of a club; (11) to accept any remuneration for the use of articles or equipment marketed by a particular dealer; (12) to be or to have been paid as a fencing master or teacher or provost teaching fencing (1958 Congress); (13) to be or to have been paid for training other persons for sports competition (1959 Congress).

D. For each Olympic Games, only those fencers who conform to the latest definition approved by the IOC will be considered as eligible amateurs (1958 Congress).

4. *Amateur Coaching*

A. *Policy*

The AFLA recognizes that the teaching of fencing by amateurs is a major instrumentality for the development of the sport in the U.S., but suggests that amateurs encourage established groups to hire a professional teacher as soon as the membership can support one.

B. *Prohibitions*

In furtherance of this policy, the following prohibitions have been enacted:

(1) An amateur coach may not receive direct or indirect compensation for his services.

(2) An amateur coach may not, without specific authorization from the Board of Directors or the National AFLA Executive Committee, regularly give instruction (even if he receives no compensation) in any case where some person or organization assesses a fee or requires a consideration for such instruction, as distinguished from the use of physical facilities or equipment. The teaching of basic skills in a recreation program or similar type of program where such instruction does not prepare for competition, shall not be considered a violation. Nothing in this paragraph is intended to prohibit mutual instruction or coaching by members of a club for their common benefit.

(3) An amateur coach may not receive reimbursement for expenses for giving private lessons or for private training of an individual for fencing competition. An amateur coach may receive reimbursement for his actual out-of-pocket expenses for travel and subsistence and for actual out-of-pocket expenses for personal equipment specifically purchased for use in connection with group coaching and in connection with the teaching of basic skills in a recreation program or a similar type of program. Nothing in this paragraph shall be construed as authorizing the payment of compensation for instruction under the guise of reimbursement expenses.

C. *Exceptions*

Notwithstanding the preceding prohibitions, the following are regarded as amateur fencers unless otherwise disqualified:

(1) Teachers of physical education or other subjects who are full-time

members of the faculty of an accredited elementary school, high school, preparatory school, college or university, who, as an incidental part of their duties, offer instruction in fencing to students regularly enrolled in such academic institutions, and who receive no extra remuneration therefore beyond their regular academic salaries.

(2) Members of the Armed Forces of the U.S., who are detailed or assigned to give instruction in fencing as part of their service duties, and who receive no extra remuneration therefor beyond the service pay of their rating or rank.

(3) Students who are degree candidates in good standing, who teach fencing at their college or university as an incidental condition of their participation in an established plan of financial aid to students, and who receive benefits under such a plan that do not exceed the amount normally given to other students of similar financial need and scholastic standing.

(4) Student counselors in summer camps who teach fencing as an incidental part of their duties, and who do not receive more than the normal stipend for camp counselors of similar age and experience.

D. Discontinuance of Amateur Coaching

The Board of Directors or its Executive Committee, may upon its own motion or upon the complaint of any person, order an investigation of any situation involving amateur coaching. Upon an affirmative finding by the Board that the continuance of such amateur coaching is detrimental to the best interests of fencing, the National Secretary shall forward to the amateur coach by registered mail a formal notification of such finding. Thereafter, the acceptance of any reimbursement of expenses by the amateur coach shall constitute a violation of the Amateur Code and shall render the individual liable to disciplinary suspension for one year, and to permanent suspension upon repetition of the offense.

5. Status of Professionals in Other Sports

The AFLA By-Laws no longer require that all persons who are professionals in other sports be automatically denied amateur status in fencing. A distinction is made between professional competitors and trainers in any sport, who are denied amateur status in fencing; and professional teachers of other sports, who are eligible for amateur status in fencing as long as they are not professional teachers of fencing. The distinction has been specifically approved by the IOC in correspondence with the FIE. However, the rules governing competitors in the Olympic Games or Pan American Games may, by reason of professionalism in another sport, deny amateur status to persons regarded as amateurs by the AFLA and the FIE. The eligibility of AFLA members for Olympic or Pan American competition, therefore, will be determined by the general definition of an amateur then currently approved by the IOC or the Pan American Sports Organization.

6. Administration of the Amateur Code

Each case in which there has been an alleged violation of the letter or spirit of the Amateur Code will be reviewed on its merits by the Board of Directors. When a violation is found to exist, the Board may terminate or suspend the amateur status of the violator, depending on the seriousness of the offense. Insofar as the action of the Board is disciplinary in character, it must be preceded by notice to the alleged violator and a hearing on the issue, if requested by the alleged violator.

7. Rules Governing Exhibitions

A. Requirement of Official Permission

No amateur member of the AFLA may participate in an exhibition without permission from the Board of Directors or the division Executive Committee, or an authorized representative of these governing bodies. Violation of this rule may result in severe disciplinary penalties.

B. Type of Exhibition

It is the policy of the AFLA that any fencing exhibition must be conducted in a manner which will properly publicize and popularize the sport. No exhibition shall be authorized under conditions that place fencing in an unfavorable light.

Exhibitions of modern fencing shall conform to the rules of the AFLA. No bouts between men and women are permitted if any score is kept. The wearing of masks is required.

Exhibitions of historical swordplay in period costume are encouraged and participation in special comedy bouts within the limits of good taste is permitted.

C. Television Programs.

Participation of an amateur fencer in television programs is strictly limited to that portion of the telecast devoted to entertainment. Appearance in any portion devoted to an advertising message is prohibited. If identified as a fencer on the program, he or she may donate the fees (if any) involved in the appearance to the AFLA or the USOC to preserve amateur status.

D. Financial Limitations

An amateur may receive reimbursement of his actual out-of-pocket expenses for travel and subsistence, and may accept a medal or prize of nominal value, in connection with an occasional fencing exhibition. He may not receive any other remuneration, and he may not devote any substantial and regular portion of his time to giving exhibitions for which he receives reimbursement of expenses and prizes.

BY-LAWS OF THE AMATEUR FENCERS LEAGUE OF AMERICA INCORPORATED

ARTICLE I

Organization and Name

The name of this Corporation shall be "The Amateur Fencers League of America, Incorporated." The Corporation is chartered and exists under the Non-Profit Corporation Laws of the Commonwealth of Pennsylvania. It is qualified as a tax exempt organization under the Federal Internal Revenue Code.

ARTICLE II

Purposes

The purposes of the Corporation shall be:

1. To promote the social welfare by advancing physical fitness through the establishment, maintenance and promotion of regular programs of athletic activity, physical conditioning and training in the art and sport of fencing.
2. To combat juvenile delinquency by providing, for children and youths, regular supervised programs of wholesome athletic activity and training in the art and sport of fencing.
3. To further individual self-discipline, build character and promote sports-

- manship by providing regular supervised training, instruction and competition in the art and sport of fencing.
4. To aid in the improvement and development of the powers of analysis, thinking, decision-making and self-discipline of the individual through training in the art and sport of fencing.
 5. To provide programs of supervised and qualified instruction with approved and trained coaches and teachers in the art and sport of fencing.
 6. To organize and supply direction for inter-collegiate and inter-scholastic fencing meets and competitions.
 7. To instruct the public and provide general information with respect to the art and sport of fencing and the benefits to be derived from participation therein through lectures and other programs on the subject useful to the individual and beneficial to the community.
 8. To disseminate knowledge and basic factual material about the art and sport of fencing.
 9. To establish classes of formal instruction in the art and sport of fencing by a regular faculty according to a regular curriculum at fixed locations.
 10. To establish and promote a nationwide program of fencing competitions.
 11. To establish and promote the growth of fencing clubs and salles d'armes throughout the country.
 12. To select and prepare individuals and teams to represent the United States in international competitions including the Olympic games and the Pan-American games.
 13. To encourage the art and sport of fencing in the United States of America, its territories and possessions, to define amateur status in respect to fencing and to formulate and enforce regulations relating thereto.
 14. To formulate and publish rules for management of fencing contests and exhibitions in the United States of America, its territories and possessions.
 15. To group all amateur fencers within its territorial jurisdiction for the purposes of conducting annual local and national championships, and competitions preliminary thereto designed to awaken and maintain interest in competitive fencing as well as in the art of fencing as a cultural promotion and exercise.
 16. To promote "people-to-people" friendship by maintaining harmonious relations with fencing systems of foreign countries and committees of other organizations interested in promoting international competitions and advancing the sport and art of fencing.

ARTICLE III

The fiscal year of the Corporation shall commence on 1 August and end on 31 July following.

ARTICLE IV Membership

Section 1. All persons who have met their obligations with respect to payment of dues as hereinafter provided in Article V shall be members of the Corporation.

Section 2. Membership shall be of six classes: Honorary, Active, Collegiate, Student, Associate and Life.

HONORARY MEMBERSHIP shall be open to anyone who shall have rendered distinguished service to the cause of fencing. A candidate shall be elected an Honorary Member of the Corporation by the Board of Directors of the Corporation upon a two-thirds vote of those present at any meeting. Honorary Members shall have all the rights and privileges of Life Members.

ACTIVE MEMBERSHIP shall be open to all persons upon payment of the dues specified in these By-Laws.

COLLEGIATE MEMBERSHIP shall be open to all persons who have attained the age of 19 but have not reached their 25th birthday as of the beginning of the current fiscal year upon payment of the dues for the current year as specified in these By-Laws.

STUDENT MEMBERSHIP shall be open to all persons who have not yet attained the age of 19 as of the beginning of the current fiscal year upon payment of the dues for the current year as specified in these By-Laws.

ASSOCIATE MEMBERSHIP shall be open to any person upon payment of the dues as specified in these By-Laws. Associate Members shall have all the rights and privileges of Active Members, subject to the limitation that they shall not be entitled to fence in competitions.

LIFE MEMBERSHIP shall be open to all persons upon payment to the Corporation of the Life Membership fee specified in these By-Laws. Life Members shall have all the rights and privileges of Active Members, but shall be exempt from the obligation of paying dues subsequent to the payment of the Life Membership fee.

Section 3. All members, except Associate Members, shall be entitled to participate in any competition held under the auspices of the Corporation, subject to the limitations of these By-Laws and to such regulations and limitations as the Board of Directors may from time to time lay down with respect to particular categories or classes of members or competitions.

All members who have paid their dues, as specified in these By-Laws on or before February 1st of each fiscal year and who have attained their 18th birthday as of that date and whose dues have been received by the National Secretary on or before that date shall have the right to vote on all matters that may be voted on by the Corporation pursuant to these By-Laws and to hold any office to which they may be elected or appointed provided that only amateurs may be elected as officers of the Corporation. The date of admission to membership is determined according to the provisions of Article V.

Section 4. Membership shall not entitle any member to any share in the assets of the Corporation, all of which are hereby declared to be irrevocably dedicated to the charitable purposes set forth in Article II of these By-Laws. All rights and privileges of membership shall cease upon death, resignation, expulsion or failure to pay dues.

ARTICLE V Fees, Dues and Arrears

Section 1. The schedule of annual dues of the Amateur Fencers League of America shall be as follows:

| Class of Membership | Annual dues | Annual Dues Prepaid for a 3-year period |
|---------------------|-------------|---|
| Active | \$10.00 | \$25.00 |
| Collegiate | 6.00 | 15.00 |
| Student | 2.00 | 5.00 |

All annual dues shall be paid directly to the Secretary of the Corporation or his duly authorized agent.

Section 2. Annual dues shall be allocated according to the following schedule, and Divisional and Sectional shares of dues shall be paid by the Secretary of the Corporation to the Treasurers of the Section and divisions to be retained by them.

Allocation of Dues

| Class of Membership | Annual | | Prepaid for a 3-year Period | |
|---------------------|------------------|-----------------|-----------------------------|-----------------|
| | Divisional Share | Sectional Share | Divisional Share | Sectional Share |
| Active | \$3.00 | \$1.00 | \$7.50 | \$2.50 |
| Collegiate | 1.00 | 1.00 | 2.50 | 2.50 |
| Student | 1.00 | — | 2.50 | — |

Where the division is not a member of any specified section, the Sectional share of dues shall be paid by the Secretary of the Corporation to the Treasurer of the Division to be retained by the Division.

Section 3. ASSOCIATE MEMBERSHIP FEE. Associate Membership in the Corporation shall be divided into the following categories.

| Class of Associate Membership | Annual Dues | Annual Dues Prepaid For a 3-year Period |
|-------------------------------|-----------------|---|
| Regular | \$ 3.00 | \$ 7.50 |
| Supporting | 12.00 | 30.00 |
| Contributing | 25.00 | 60.00 |
| Class "A" | 50.00 (or more) | 120.00 |

One half of this fee shall be paid over by the Secretary of the Corporation to the Treasurer of the Division to which the member belongs to be retained by the Division.

Section 4. LIFE MEMBERSHIP FEE. The Life Membership fee shall be \$150.00. One-half of this fee shall be paid over by the Secretary of the Corporation to the Treasurer of the Division to which the member belongs to be retained by the Division, except that if the member also belongs to a section, the Secretary of the Corporation shall pay to the Treasurer of the Section \$10.00 to be retained by the section, and \$65.00 to the Treasurer of the Division.

Section 5. All dues are payable on application for membership and thereafter on or before August 1 of each fiscal year.

Section 6. All dues paid to the Secretary of the Corporation shall be recorded by him and unless allocated to a section or division paid over to the Treasurer for general Corporation purposes.

Section 7. A new member is not admitted to membership and an old member is not in good standing until his dues and fees have been received by the Secretary of the Corporation or by a duly authorized agent. Payment of dues to a divisional secretary or other officer or duly appointed agent will render a fencer eligible to fence. However, no person will be eligible to vote in League affairs at the national level until his dues for the fiscal year in which he seeks the right to vote are received by the National Secretary, and only if received by the National Secretary prior to February 1st of that fiscal year.

ARTICLE VI Officers

Section 1. The officers of the Corporation shall consist of a President, an

Executive Vice President, two additional Vice Presidents, a Secretary and a Treasurer.

The President shall appoint as Foreign Secretary a member of the Corporation with the consent of the Board of Directors.

Section 2. The President shall be the chief executive officer of the Corporation and shall preside at all meetings of the AFLA, Inc. and of the Board of Directors, and perform such other duties as usually pertain to that office and which are not inconsistent with these By-Laws.

Section 3. The Executive Vice President and the two additional Vice Presidents shall perform such duties as the President shall delegate to them. They shall be members of the Executive Committee. (See Article VII, Section 8).

Section 4. In the absence of the President, the Executive Vice President shall preside at all meetings of the Corporation and of the Board of Directors. In the absence of the President and the Executive Vice President the additional Vice Presidents in order of their seniority (or if of equal service then by drawing lots) shall preside at all meetings of the Corporation and of the Board of Directors.

Section 5. The Secretary shall conduct all official correspondence of the Corporation, keep a record of all meetings of the Corporation and of the Board of Directors, issue notices to members of all meetings of the Corporation, and perform such duties as may be assigned to the Secretary by these By-Laws or by the President. If the Board appoints a Recording and/or Corresponding Secretary, the Secretary shall prescribe their duties and supervise their activities.

Section 6. The Treasurer shall keep the accounts of the Corporation; shall receive all moneys, fees, dues, etc; shall pay all bills approved by the Board of Directors; and shall preserve vouchers for such disbursements. The Treasurer shall, at the Annual Meeting, submit a report, audited by a committee of the Board of Directors, of the financial transactions of the preceding fiscal year. The Treasurer shall keep all funds of the Corporation in such account or accounts, each subject to withdrawals upon such signature or signatures, as the Board of Directors may from time to time prescribe.

Section 7. The Foreign Secretary shall conduct all official correspondence of the Corporation addressed to representatives or officers of foreign or international fencing federations or associations; shall report all activities of the FIE and make periodic reports thereon to the President; and shall perform such other duties as may be assigned by the President, the Board of Directors or these By-Laws.

Section 8. Before exercising their offices the President, the Secretary, and the Treasurer shall each file such bond for the faithful performance of his duties as the Board of Directors may approve.

ARTICLE VII Board of Directors

Section 1. Responsibility for the general management and policies of the Corporation shall be vested in a Board of Directors composed of the officers of the Corporation, the Chairman of each Section, the Chairman of each Division of the Corporation and Additional Directors from the Divisions of the number hereinafter specified:

(a) Each Division shall be entitled to one Director for the first 75 members

(who shall be the Chairman of the division) and an Additional Director for each succeeding 75 members or major fraction thereof. Members, for the purpose of entitlement to Additional Directors, shall be members in good standing as of the end of the fiscal year preceding the year in which the Directors take office.

- (b) The President of the National Fencing Coaches Association of America ex-officio shall be a director of the Corporation.

Section 2. The officers of the Corporation shall be elected bi-annually by the membership at the Corporation in the manner specified in these By-Laws.

The Divisional Chairmen and Additional Directors, if any, of each Division shall be elected annually by the membership of each Division in the manner specified in the By-Laws of the Corporation and of the Division.

- (a) In the election for Additional Directors each divisional member eligible to vote shall be entitled to cast as many votes as there are Additional Directors to be elected. Each such member may cast the whole number of his votes for one nominee or distribute them upon two or more nominees as he may prefer.

Section 3. The Board of Directors shall be vested with full powers of management of the Corporation subject to these By-Laws.

Section 4. At any meeting of the Board of Directors a quorum shall be seven members present in person. On failure of a quorum a lesser number shall have the power to adjourn to a given time and place. The date, place and time of each meeting shall be designated by the President.

Section 5. The Annual Meeting of the Board of Directors shall be convened, upon not less than 14 days' notice, during the month of September.

Section 6. Special Meetings of the Board of Directors may, and upon written request of seven or more members must, be called by the President on 14 days' notice. All notices shall state the object of the meeting, and business not mentioned therein may not be acted on at any Special Meeting, except that appropriations shall be in order at any meeting of the Board without notice.

Section 7. Voting by Mail.

- (a) Any specific question or matter which might be passed at a special Meeting of the Board shall be submitted to a vote by mail at the discretion of the President, or upon written request of any seven members of the Board of Directors who hold membership, in the aggregate, in three or more Divisions.
- (b) On vote by mail, the Secretary of the Corporation shall mail to each member of the Board a clear statement of the question to be voted upon, and of the date on which voting shall be closed, with a request that each member cast his vote thereon and communicate it to the Secretary prior to the closing date. The closing date shall be not less than 14 days after the mailing of the question.

Section 8. The Board of Directors shall have power to constitute an Executive Committee composed of not less than five members which Committee shall include the President, the Executive Vice President, the additional Vice Presidents and the Secretary. Such Executive Committee, if constituted by the Board, shall have such powers as the Board may by resolution prescribe, provided, however, that the power so delegated shall be limited to the power to take action until the next meeting of the Board of Directors.

Section 9. The Board of Directors may appoint a Recording and/or Corresponding Secretary to serve without vote until the subsequent Annual Meeting of the Board and to perform such duties as may be assigned to them by the Board, the President, the Secretary and the Treasurer.

Section 10. The Board of Directors shall appoint annually legal counsel to advise and represent the Corporation, its directors and officers.

Section 11. The Board of Directors shall have power to define amateur status and in the absence of action to the contrary the Board of Directors shall be deemed to have adopted the following definition:

An amateur fencer is one who participates in fencing solely for the love of the sport, who has not derived direct or indirect financial benefits from competition or exhibitions in fencing and who has never been a professional teacher of fencing or a professional competitor or trainer in any branch of athletics or who has been reinstated as an Amateur by the Board of Directors.

The Board of Directors shall have the sole power to interpret this Section, to enact an amateur code for the guidance of the members of the Corporation; to prescribe and apply disciplinary penalties for infractions of the amateur code, including warning, reprimand and temporary or permanent suspension from amateur competition, according to the circumstances, and to grant reinstatement hereunder. Members of the Armed Forces of the United States duly appointed or assigned as instructors of fencing are exempt from the provisions of this section when in the discharge of such official duty.

Section 12. The Board of Directors shall have power to formulate, establish, and publish the rules governing all amateur member fencing competitions and all exhibitions in which an amateur member of the Corporation shall participate, and in the absence of action to the contrary the Board of Directors shall be deemed to have formulated, established and published the following rules:

- (a) All amateur fencing competitions in the United States, its territories and possessions, shall be conducted only under the rules and sanction of the Amateur Fencers League of America, Incorporated.
- (b) An amateur fencer willfully competing in fencing competition in the United States, its territories and possessions, not held under the rules and sanction of the AFLA, Inc., shall be liable to suspension and may be held ineligible to enter any contest under Corporation auspices for such period of time as the Board of Directors may determine.
- (c) Any amateur knowingly competing in fencing competition with any one who has been suspended or disqualified by the Board of Directors of this Corporation renders himself liable to suspension and may be held ineligible to enter any contest under Corporation auspices for such period of time as the Board of Directors may determine.
- (d) Professionals shall be permitted to compete in amateur competition only under such rules and conditions as the Board of Directors may from time to time prescribe.

Section 13. Board of Directors to arrange for National Championships. The Board of Directors shall receive bids from the various divisions to hold the annual National Championship Tournament and shall select the time and place thereof. In no event shall the National Championship Tournament be held prior to the 30th day from the mailing of notice pursuant to Section 2 of Article XII.

Section 14. Disciplinary Powers of the Board of Directors: The Board of

Directors by a two-thirds vote of the members voting shall have power to reprimand, suspend, deny continuation of membership to, or expel any member whose conduct may be deemed detrimental to the welfare, interests or character of the Corporation, always provided, however, that any action other than reprimand may be taken only after the following conditions have been satisfied: (a) notice must be served upon the members of the Board and upon the member against whom the proposed action is to be taken, setting forth generally the character of the conduct forming the basis for the proposed action; and (b) if requested by the member to be disciplined or by three members of the Board, within ten days after the mailing of notice of the proposed action, a committee of not less than three members of the Corporation must be appointed by the President to investigate the conduct charged against the member, said committee must give the member an opportunity to be heard in respect of the charge and, after completing its investigation, must file a report favoring the action proposed to be taken by the Board.

Section 15. The Board of Directors may at their discretion, and upon the same vote as is provided for the election of Honorary Members in Article IV of the By-Laws, elect an Honorary President, an Honorary Vice President and/or an Honorary Secretary-Treasurer. Any such honorary officer shall be elected for life and shall be entitled to all the privileges of an Honorary Member and to attend all meetings of the Board of Directors but shall not be entitled to vote as a member of the Board.

ARTICLE VIII

Order of Business for All Meetings of the Corporation and the Board of Directors

- | | |
|--|---------------------------------|
| 1. Reading of Minutes | 4. Elections (when appropriate) |
| 2. Report of Officers and Committees | 5. Unfinished Business |
| 3. Proposed Amendments to By-Laws (when appropriate) | 6. New Business |

ARTICLE IX

Procedure for Meetings of the Board of Directors and of the Corporation

Unless otherwise provided for in these By-Laws or in the Pennsylvania Non-Profit Corporation Law, procedure at meetings and procedure relating to contested elections shall be governed by the provisions of Roberts Rules of Order.

ARTICLE X

Committees of the Board of Directors

Section. 1. Subject to the provisions of these By-Laws, the President, with the approval of the Board of Directors or of its Executive Committee, shall have power to create and appoint the members of such standing and special committees as he may deem necessary or appropriate, designate the chairmen thereof, and assign functions thereto.

Section 2. Every committee shall meet from time to time at the call of the Chairman thereof, and it shall be the duty of the Chairman to call a meeting upon the written request of a majority of the members of his committee or of the President.

Section 3. The Chairman of each Committee shall transmit a full report of its activities to the President of the Corporation prior to the Annual Meeting of the Corporation, and each Committee shall make such special reports as the President or Board of Directors shall direct.

ARTICLE XI

Meetings and Elections of the Corporation

Section 1. The Annual Meeting of the Corporation shall be convened in the same city as and during the national championship tournament, at a date and time fixed by the President of the Corporation.

Section 2. Special Meetings of the Corporation may be called by the President, or the Board of Directors at a time and place of which there shall be at least 30 days' notice. Business not specified in the notice of any such meeting shall not be acted upon.

Section 3. At the Annual Meeting held in odd numbered years there shall be elected by the membership a Nominating Committee of not less than five voting members of the Corporation which shall nominate candidates for the offices of President, Executive Vice President, additional Vice Presidents, Secretary and Treasurer, and for the National Divisional Directors, which candidates shall be voted upon at the next Annual Meeting.

A motion to close nomination for members of the Nominating Committee shall not be in order until nominations have been made of members of the Corporation who are members of at least five different Divisions. This Committee shall file its nominations with the Secretary of the Corporation on or before February 1st next ensuing; and the Secretary shall, on or before April 1st thereafter, mail to each member of the Corporation a copy of the nominations filed by the Nominating Committee, or such notice shall be published in the official publication of the Corporation within the prescribed time.

Section 4. Additional nominations may be made on written petition of not less than 50 voting members of the Corporation provided such petition is presented to the Secretary of the Corporation by May 1st.

Section 5. If no additional nominations for an office are made, the Secretary of the Corporation shall cast at the Annual Meeting a unanimous ballot for the candidate nominated for such office by the Nominating Committee. Where additional nominations have been made for any office, voting on the candidates for such office shall be by voting members only, on ballots prepared by the Secretary and mailed to all voting members as provided in Article XII of these By-Laws. Where three or more nominations have been duly filed for any office, the ballots shall be prepared and counted in accordance with a system for preferential voting approved by the Board of Directors. Voting by proxy shall not be permitted in a contested election.

(a) The ballot shall be marked by putting a cross or other clear indication of choice opposite the name of the candidate or candidates for whom the voter desires to vote.

(b) The ballot shall be sealed in the envelope provided; the envelope shall

be signed by the voter and returned to the Corporation Secretary on or before June 1st.

- (c) The envelopes so received are to be opened by the tellers only after the polls for election of officers are declared open at the Annual Meeting of the Corporation.

Section 6. The officers of the Corporation shall be elected by a majority of the votes cast and shall hold office for a period of two years thereafter until 31 July of that year and until their successors are elected and qualified. This provision shall become effective as of the fiscal year commencing August 1, 1974.

Section 7. At any meeting of the Corporation a quorum shall consist, unless specifically otherwise provided for particular purposes of meetings, of 25 members, present in person or by proxy, and all business before the meeting other than elections may be voted on in person or by proxy, and a majority vote of those voting shall rule, provided, however that no proxy shall be voted on a proposed change to the By-Laws unless the proxy specifies whether it is to be cast for or against the amendment.

Section 8. Vacancies in the offices of President, Executive Vice President, additional Vice Presidents, Secretary, Treasurer, or National Divisional Directors, occurring between Annual Meetings shall be filled for the unexpired term by the Board of Directors.

ARTICLE XII

Notices and Mailings of Ballots

Section 1. Any notices of ballots shall be deemed validly given or delivered if mailed to a member at the address last designated by such member to the Secretary of the Corporation or, failing such designation, to the member at the address of such member, furnished by the secretary of his or her division.

Section 2. Notice of the Annual Meeting shall be given to all voting members of the Corporation by the Secretary, which notice shall be mailed or published in the official publication of the Corporation on or before May 31 prior to such meeting and shall contain a statement of the name or names of the officer or officers to be elected by unanimous ballot, if any, and otherwise a reference to the candidates to be voted on at the meeting. Such notice shall include or be accompanied by the text of any amendment to these By-Laws to be acted upon at such Annual Meeting.

Section 3. Where any officer is to be voted on at the Annual Meeting, ballots for the candidates and return envelopes shall be mailed to all voting members on or before May 15 prior to such meeting.

ARTICLE XIII

Divisions and Sections

Section 1. In order to facilitate the development of fencing in the United States of America, its territories and possessions, the Board of Directors may,

upon application in conformance with these By-Laws, create administrative units to be known as Divisions. Such divisions shall be created by a charter designating the territorial limits of jurisdiction and setting forth such powers as the Board may prescribe and reserving to the Board the right and power to rescind or amend such charter at its discretion or when the total number of members in the division has fallen below ten.

Membership in a division shall be limited to persons eligible for membership in the Corporation who reside in, or belong to a fencing club located within the territorial limits of the Division and who are not members of another division.

Section 2. In order to encourage annual interdivisional competitions throughout the United States of America, its territories and possessions, the Board of Directors is empowered to create non-administrative units to be known as Sections. Such sections shall encompass large areas whose geographical limits shall be fixed and recorded by the Board. All divisions lying within the area covered by the section shall be members of the section and shall support the annual Sectional Championships as provided in these By-Laws.

Section 3. Subject to the directives and limitations contained in these By-Laws, each division and section is empowered to draft the By-Laws under which its respective functions shall be carried out.

Section 4. The application for a Charter, addressed to the Secretary of the Corporation, shall be signed by not less than ten persons, accompanied by the dues and fees for the current year prescribed in these By-Laws and outlining the territorial jurisdiction sought for the proposed Division.

Section 5. The Board of Directors shall, at its discretion, grant or deny the request for a Charter. If granted, the Charter shall be the Constitution of the Division and the members thereof shall, within six months, adopt rules for the administration of local affairs not inconsistent with these By-Laws and submit a copy to the Secretary of the Corporation.

Section 6. There shall be an Annual Meeting of the Division, of which there shall be at least 15 days' notice, and a quorum shall consist of seven voting members present in person or by proxy.

Section 7. At the Annual Meeting of the Division there shall be elected a Chairman, one or more Vice-Chairmen, Secretary, Treasurer (or Secretary-Treasurer), Additional Directors and members of the Executive Committee. The casting of ballots for officers, directors and members of the executive committee may be made in person or by proxy and nominations from the floor at the time of meeting may be made unless the By-Laws of the Division specify to the contrary.

Section 8. The management of the Division shall be vested in an Executive Committee which shall consist of the elected officers and directors and other annually elected members in accordance with Section 7 of this article.

Section 9. The Division Chairman shall, within the time and format specified by the Secretary of the Corporation file a complete report of the membership, finances and activities of the Division for the current year.

Section 10. Membership in a Section is limited to members of the component Divisions.

Section 11. The management of a Section shall be vested in an Executive Committee composed of the Chairmen of the Divisions which comprise the Section, one other representative from each Division and any Additional Directors from a Division in the Section. The additional representative shall

be appointed by the executive committee of each Division. The Executive Committee shall elect from among its membership a Chairman and a Secretary-Treasurer. The Chairman of the Section shall be a member of the National Board of Directors but will not be entitled to more than one vote. He shall within the time specified by the Secretary of the Corporation file with the Secretary of the Corporation a report of the finances and activities of his Section for the year.

Section 12. The disciplinary powers of the Executive Committee shall be limited to the competitive penalties of expulsion or exclusion. All other discipline shall be referred to the Board of Directors.

ARTICLE XIV The National Division

Section 1. All members of the Corporation who are not eligible, or do not apply for membership in a division shall be members of the National Division.

Section 2. The National Division shall be administered by the officers of the Corporation and the Board of Directors.

ARTICLE XV Colors

The colors of the Corporation shall be Dark Blue and Gold.

ARTICLE XVI Amendments

These By-Laws may be amended at any annual meeting of the Corporation or at any special meeting of the Corporation called for that purpose by a vote of the majority of those present in person or by proxy. Voting at such meetings is subject to the provisions of Section 7 of Article XI of these By-Laws. Notice of any proposed amendment setting forth its general tenor shall be given by publication in the official publication of the Corporation or by direct mailing to all voting members of the League at least 90 days in advance of the meeting.

ARTICLE XVII Taking Effect of Revision

These By-Laws shall take effect on September 1, 1964 after their adoption at the Annual Meeting of the Corporation held in Atlantic City on July 10, 1964. Unless otherwise specified, amendments to these By-Laws shall take effect on August 1 next after their adoption. Copies of the amendments so adopted shall be mailed to every Division of the Corporation within 30 days after their adoption and notice of their adoption shall be given to all members by publication in the official publication of the Corporation or by direct mailing. All members of the Corporation who shall not have tendered a resignation prior to the effective date of these By-Laws

shall be deemed to have accepted their provisions and to have waived any rights which they may have had theretofore pursuant to the Constitution and By-Laws in effect prior to the taking of these By-Laws.

ARTICLE XVIII Separate Accounts

Section 1. International Development Account. The Board of Directors is directed to establish and maintain an International Development Account for the purpose of providing for the travel and related expenses of competitors, coaches, and officials, as selected by the Board of Directors, to participate in the following events:

- a. World Olympic Games
- b. Pan-American Olympic Games
- c. World Fencing Championships
- d. World Junior Fencing Championships
- e. Such other major international competitions as may be approved for participation by the Board of Directors.

Section 2. United States Development Account. The Board of Directors is directed to establish and maintain a United States Development Account for the following purposes.

- a. Development of promotional materials useful in publicizing fencing and fencing activities among students and the general public.
- b. Organization of programs for the holding of fencing clinics throughout the United States.
- c. Award of Scholarships for fencing instruction in designated salles, clubs, schools, and institutions, or with selected coaches, to promising fencers in all weapons as chosen by the Board of Directors.
- d. Production and purchase of films and other instructional material as an aid to the teaching of fencing and as a means of promoting interest in, and understanding of, the sport.
- e. Creation of facilities and development of programs for the training of professional and amateur coaches and instructors.
- f. Establishment of the full-time, salaried post of Executive Secretary of the Corporation.
- g. Establishment of a permanent headquarters and office for the Corporation.
- h. Such other similar domestic development purposes as may be approved by the Board of Directors.

Section 3. Contributions to Separate Accounts. Any contributor to the Corporation may direct that his gift be placed, in whole or in part, in one or more of the Separate Accounts provided for in these By-Laws and his instructions shall be carried out by the Board of Directors.

Contributions to such accounts qualify as a deductible charitable contribution under the rules of the Internal Revenue Department.

The Board of Directors shall have the right to place all or part of any contribution made to the Corporation in one or more of the Separate Accounts when the donor provides no instructions for the application of his gift.

Subject to the provisions of these By-Laws, the Board of Directors shall have the right to place revenue, income, and property of the Corporation in one or more of the Separate Accounts.

Section 4. Management of the Separate Accounts.

- a. The management of the Separate Accounts provided for in these By-Laws shall be vested in a board of three fiduciaries, one of whom shall be the President of the Corporation and two of whom shall not be directors or officers of the Corporation.
- b. The President of the Corporation shall serve as fiduciary for the term of his office and until his successor has been elected and qualifies.
- c. One of the remaining two fiduciaries shall be elected by the Board of Directors to serve for a term of two years and until his successor has been elected and qualifies. Thereafter, the term of this office shall be four years.
- d. The remaining fiduciary shall be elected by the Board of Directors to serve for a term of four years and until his successor has been elected and qualifies. Thereafter, the term of this office shall be four years.
- e. At least six months prior to the expiration of the term of a fiduciary other than the President of the Corporation, the fiduciary shall give notice to the Board of Directors of his willingness to serve for another term of office. In the event the fiduciary notifies the Board of his willingness to serve, the Board shall vote on the question whether to elect the fiduciary to another term of office. In the event the fiduciary does not receive a majority of the votes cast, or in the event the fiduciary is unwilling to serve for another term of office, then the remaining fiduciaries shall nominate another candidate for the approval of the Board of Directors. In the event that such nominee does not receive the approval of the Board of Directors, the remaining fiduciaries shall nominate additional candidates until the Board of Directors elects one of such nominees to office.
- f. In the event of the death, resignation, or inability to serve of a fiduciary, the remaining fiduciaries shall nominate a candidate to fill the unexpired term for the approval of the Board of Directors in accordance with the procedure set forth in the preceding paragraph.
- g. The board of fiduciaries shall have power to invest and reinvest the corpus of each such Account with due regard for both the earning of income and the appreciation of capital. The Treasurer of the Corporation shall be fully informed as soon as practicable but in any case within 30 days of any transaction involving the corpus of any special account.
- h. The board of fiduciaries shall manage the Account in accordance with the principles of prudent management set forth in the Laws of Pennsylvania respecting fiduciaries, trusts and estates, except that the fiduciaries shall not be limited to investing in what are commonly known as "legal investments."
- i. The income from each Separate Account shall be paid over to the Corporation semi-annually and shall be expended for the purposes prescribed for each Separate Account.
- j. The principal of each Separate Account shall remain intact and not be subject to invasion or distribution by the fiduciaries for a period of 15 years from the date of its creation or until the market value of the principal of the Separate Account shall equal \$100,000. Thereafter, at the direction of the Board of Directors, the board of Fiduciaries shall have the power to invade principal and pay over to the Corporation an amount not to exceed in any one year 10% of the market value of the principal of the Separate Account.



THE BEST

AMERICAN FENCERS' SUPPLY Co.

2116 Fillmore Street
San Francisco, California 94115

"just a touch
better than the rest."

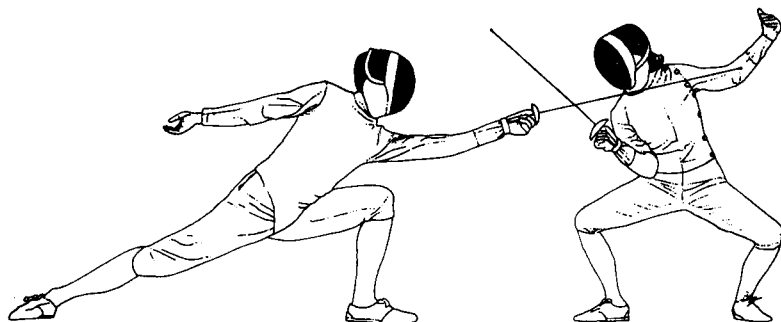

santelli
fencing equipment

george santelli, inc., four twelve sixth avenue, new york, n.y. 10011 phone AL 4-4053

NCAA RULES

PREFACE

These chapters have been compiled with the aim of eliminating, as far as possible, past sources of confusion in the application of the rules to collegiate fencing, chiefly in the area of the management of competitions.

The effort to develop an integrated set of national rules that would be generally applicable to intercollegiate and interscholastic meets as they have usually been conducted began in 1969. Walter Langford of Notre Dame University, then Chairman of the NCAA Rules and Meet Committee, with the cooperation and encouragement of the National Fencing Coaches Association of America, appointed a sub-committee to prepare a preliminary draft of intercollegiate and interscholastic rules. Richard J. Perry (University of Detroit), Chairman, John LeBar (Duke University), Stanley S. Sieja (Princeton University) and James White (University of California at San Diego), constituted the sub-committee.

At the annual meeting of the NCAA Fencing Rules Committee in 1971 at Berkeley, California, a draft of these rules was presented. In 1972, at Waltham, Massachusetts, the committee further refined the rules which are herein presented. Part Five, *Organization of Competitions*, is unique to intercollegiate and interscholastic fencing. It sets forth the rules for the NCAA Championships, and a general procedure that is recommended for use in collegiate and scholastic meets. Part Six, *Disciplinary Rules for Competitions*, is an adaptation of the AFLA Rules, but again the changes specified should be duly noted.

The Committee expresses its appreciation to all the coaches and fencers who have contributed to this publication.

1972 NCAA Rules Committee: Robert Kaplan (Ohio State) Chairman
Hugo M. Castello (New York University)
Richard F. Oles (Johns Hopkins)
Archie Simonson (Wisconsin)
Raoul Sudre (Cornell)
Muriel Bower (Northridge State)
Richard J. Perry (University of Detroit)
Rules Editor

1973 NCAA Rules Committee: Robert Kaplan, Chairman
Muriel Bower
Hugo M. Castello
Richard Oles
Clifford Kirmss (Stevens Institute)
James White (UC San Diego)
Richard J. Perry, Rules Editor

PART ONE—GENERAL RULES, AND RULES APPLICABLE TO ALL WEAPONS

These rules are the same as are found in Part One of the Amateur Fencers League of America Fencing Rules and Manual, 1974 edition. Any further changes made by the FIE and/or the AFLA will be incorporated into these rules, unless otherwise determined by the NCAA Fencing Rules Committee.

It is presumed that all competitors, coaches and officials are cognizant of the rules.

1 These rules are obligatory for the NCAA Championships. Their adoption for use in regional or conference tournaments, intercollegiate dual and multiple meets, and interscholastic tournaments and meets is recommended to the appropriate authorities.

2 Once so adopted, they shall apply, with only such exceptions as are agreed upon in writing in advance of the start of the event by the participating coaches and/or the constituted governing authority, (eg., Bout Committee). Articles 3-75 are the same as the same numbered articles in the AFLA Rules Book, except:

Article 45d. The duration of the regulation collegiate bout for five touches is four minutes of fencing time.

PART TWO—FOIL

Articles 201-237 are the same as the same numbered articles in the AFLA Rules Book.

PART THREE—EPEE

Articles 301-319 are the same as the same numbered articles in the AFLA Rules Book.

320 If the score in a bout is tied at 4-4, and a double touch is scored, the score then becomes 5-5, and the contestants fence for a final touch with no intervening double touches being scored. When a single deciding touch has been landed, the score for the contestant who was touched is recorded D/5, and for the contestant who landed the touch, V/5.

321b When the regulation time limit expires before a result has been achieved, if the score is tied at less than 4-4, it is raised to 4-4, and the contestants fence for one touch with time out.

Articles 322-331 are the same as the same numbered articles in the AFLA Rules Book.

PART FOUR—SABRE

Articles 401-422 are the same as the same numbered articles in the AFLA Rules Book.

PART FIVE—ORGANIZATION OF COMPETITIONS

501 The Annual NCAA Fencing Championships are organized according to a set of rules which is reviewed each year by the NCAA

Fencing Rules Committee at its annual meeting. These rules are then circulated by the host institution to NCAA member institutions which have previously signified intention to enter the Championships.

502 a. It is recommended that regional and conference tournaments be organized under the general provisions of the following articles which pertain, subject to specific modifications as required by the various intercollegiate conferences, or by the executive committees for the various regional tournaments.

b. Similarly, collegiate invitational tournaments for individuals, but not for team honors, should be organized under the general provisions as required by the various collegiate conferences, or by the host organization. Cf. 45d, 320, 321

c. It is recommended that intercollegiate dual and multiple meets should be organized and conducted under the general provisions of the following articles which pertain. Specific articles may be modified for specific meets by clearly understood mutual agreement of the participating coaches.

503 THE ORGANIZING COMMITTEE is the group of persons responsible for organizing a competition. For the NCAA Fencing Championships, the Organizing Committee is appointed by the officers of the host institution. For regional and conference tournaments, for invitational tournaments, for dual and multiple meets, the Organizing Committee is customarily appointed by the host institution or organization. For the NCAA Championships, if a member of the NCAA Fencing Rules Committee, or a Bout Committee member is located near enough to the host institution for quick communication, his appointment to the Organizing Committee is recommended.

504 The NCAA FENCING RULES COMMITTEE consists of six members, appointed sequentially for three year terms by the NATIONAL COLLEGIATE ATHLETIC ASSOCIATION. This committee is the final authority on the rules of competition and on the conduct and organization of the NCAA Championships, and is responsible for the revision of this portion of the Rules Book.

505 a. THE BOUT COMMITTEE is the operating committee of each annual NCAA Championship Tournament. The five members are appointed by the NCAA Rules Committee each year for the following year's tournament. The host coach may not be appointed to the Bout Committee. At least one of the five Bout Committeemen must also be a member of the NCAA Rules Committee. The host coach of the succeeding year's NCAA Championships, and the Rules Editor of the NCAA Rules Committee must be included in the Bout Committee. The Chairman of the Bout Committee is appointed by the NCAA Rules Committee, and is responsible to them for the overall conduct of the tournament of which his committee has charge.

b. For Regional and Conference tournaments, with some detailed variations, the Bout Committee is customarily appointed by the participating institutions or organizations, and is responsible to the appointing authority for the overall conduct of the tournament. Many of these committees elect their own chairman.

c. For multiple meets, the participating coaches are encouraged to agree to a three member bout committee consisting of coaches and/or officials.

d. For dual meets a bout committee usually is not appointed. However,

should representatives of the participating institutions so agree, there is no reason why they should not appoint one. A bout committee should not be appointed unilaterally by the host institution without agreement as to its members by the visiting institution.

506 a. THE SEEDING COMMITTEE FOR THE NCAA Championships is appointed for each tournament by the NCAA Rules Committee, and is responsible to the appointing authority. It should include at least one member of the Rules Committee, and a number of members sufficient to represent the various regions and conferences from which entries will come. The host coach may not be appointed to the Seeding Committee. One member of this committee should be located close enough to the host institution to facilitate quick communication.

b. Seeding Committees for the regional and conference tournaments are customarily appointed by the various conference executives, or by representatives of the participating institutions.

c. Seeding Committees for invitational tournaments are usually appointed by the host organizations and institutions.

507 RESPONSIBILITIES OF THE ORGANIZING COMMITTEE:
NCAA Championships:

a. Selecting the dates for the NCAA Championships, subject to the final approval of the NCAA Fencing Rules Committee.

b. Preparation of the site and facilities for contestants, coaches, officials and spectators.

c. Securing and preparation of strips, electric apparatus, scoring equipment; securing of experts and technicians to keep this equipment operating at maximum efficiency during the course of the tournament. In situations where participating institutions bring in equipment (machines and reels) for use during the tournament, the host institution MAY voluntarily repair those which become defective while in use, but is NOT RESPONSIBLE for doing so.

d. Preparation of and operation of scoreboards, scorecards, and the scorekeeping system; training of scorekeeping and timekeeping personnel. Operation of the scorekeeping system during the tournament, with the approval of the Bout Committee. (However, in the final accounting of the scores and breaking of ties, scoring personnel are responsible to the Bout Committee.) Publication of final standings and results to participating institutions.

e. Preparation of the Bout Schedule, subject to Bout Committee approval.

f. Securing of, and expense reimbursement of, competent directors and side judges from among the amateur and professional fencers within a practical distance of the site.

g. Handling of all press relations and public relations connected with the tournament.

h. Conduct of opening and closing ceremonies.

508 Responsibilities of the Organizing Committee for regional and conference tournaments, invitational tournaments, multiple and dual meets: All of the eight functions in Art. 507 should be the responsibility of the Organizing Committee or its counterpart for the specific event. In many cases the host coach serves as the organizing committee for dual or multiple meets.

509 RESPONSIBILITIES OF THE BOUT COMMITTEE: NCAA Championships:

a. Supervision, with the Organizing Committee, of the time schedule for

conducting the Championships. Seeing to it, along with the Organizing Committee, that the competition progresses as closely as possible to the predetermined time schedule. Ultimate responsibility for these functions rests with the Bout Committee.

b. Assignment of directors and side judges and ground judges to all strips in all weapons at all times. The Bout Committee can organize the conduct of this function in any one of several ways, but it cannot delegate its responsibility to anyone not a member of the Bout Committee. The Committee is empowered to assign, replace or remove any director, side judge or ground judge without explaining to anyone the reasons for its actions.

(1) However, a director cannot be replaced until the bout he is then directing has been completed, unless it is a situation involving personal injury to the director, or at the director's own request.

(2) A side judge or ground judge may be replaced during a bout, so long as the action is stopped and the request for replacement originates with the judge himself.

c. Arbitration of directors' decisions which are formally and properly protested to the Bout Committee; Cf. 614. This committee is the FINAL AUTHORITY regarding protested decisions made during the competition over which it has charge.

d. Certification of the scoring, and of the final standings at the end of the tournament.

e. At the end of the tournament the Bout Committee ceases to exist.

510 The responsibilities and functions of Bout Committees for regional and conference tournaments and for individual tournaments are customarily similar to those outlined in Art. 509. However, they are sometimes more broadly shared with the organizing committee than is the case in the NCAA Championships. For dual and multiple meets, the major function of the bout committee is to serve as the final jury of appeal for protested decisions of individual officials.

511 RESPONSIBILITIES OF THE SEEDING COMMITTEE:
NCAA Championships:

The assignment of individual fencers to each of a predetermined number of preliminary pools; Cf. 532. The assignment of fencers who advance from the preliminary pools to the Final Round of 24 fencers to their various positions in that pool will be made by the Bout Committee.

512 The responsibilities of the Seeding Committees for regional and conference tournaments and for individual tournaments are customarily similar to those in the NCAA Championships, with specific variations. In multiple meets the host coach usually has the responsibility of determining the order in which participating teams will meet. This function may be performed in some cases within specific parameters established by various athletic conferences. It is highly desirable that all participating teams be informed of the time schedule of events and designation of "visiting" and "home" teams at least ten days before the date of competition.

521 a. A DUAL MEET is a three weapon meet between two teams of nine men each for a total of 27 bouts. Since no collegiate bouts end in ties, there can be no tie meets.

b. A MULTIPLE MEET is more than one dual meet involving more than two teams as one site on one date.

522 a. ORGANIZATION: DUAL MEET: Each of the 3 foil fencers of Team A will meet each of the three foil fencers of Team B in

one bout, for a total of 9 bouts. The same procedure is followed in Epee and Sabre for a total of 27 bouts.

b. The "visiting" team will be assigned the Direct bout order (Arabic numerals, below), while the "home" team will be assigned the Indirect bout order (Roman numerals below) for all of the 27 bouts.

c. Order of Bouts: visiting team, Arabic numerals; home team Roman numerals: 1-I; 2-II; 3-III; 1-II; 2-III; 3-I; 1-III; 2-I; 3-II. The same order is followed in all three weapons.

523 a. When a dual meet is conducted on one strip, the order of fencing should be: 3 bouts sabre, then 3 bouts foil, then 3 bouts epee; 3 sabre, 3 foil, 3 epee, 3 sabre, 3 foil, 3 epee.

b. When a dual meet is conducted on two strips, the order of fencing should be: 3 bouts sabre, then 3 foil and 3 epee simultaneously, this order followed three times.

c. When a dual meet is conducted on three strips, then nine bouts in one weapon are run consecutively on each strip.

524 a. Starting line-ups should be submitted to the scorers ONLY by the coaches or the team captains, and only in writing. If the coach or captain of the VISITING team requests it, the coach or captain of the HOME team must submit his starting lineup to the scorers first. Following the submission of starting line-ups to the scorers, they may not be changed until AFTER the first round in each weapon has been fenced.

b. One fencer may not compete in more than one weapon in one meet. If a team consists of fewer than 9 men, the opposing coach or captain may claim as forfeit any bouts the deficient team is unable to fence under these rules. Scores of forfeited bouts are 5-0 against the forfeiting team.

525 SUBSTITUTIONS: It is the explicit responsibility of the coach or captain of the team desiring to substitute into the team's starting line-up that ANY substitution made conform to these rules. A "substitute" is a fencer whose name is on the institution's official eligibility list, but who does not fence the first three bouts in any weapon.

a. Even after a bout has been called, a coach or captain may ask for 1 minute time out to substitute another fencer into that bout; Cf. 525f. The coach or captain who has asked for this 1 minute time out MUST proceed with the substitution. If he leaves the fencer originally scheduled for the bout in to fence it, then the opposing team has the right to claim that bout as forfeit.

b. Once the director has called "On Guard" to begin a bout, no substitution may be made for either fencer. (Exception Cf. 647)

c. The substitute fencer cannot have fenced in another weapon in that dual meet.

d. The substitute cannot have met his opponent previously in that dual meet.

e. Two fencers may fence the 3 bouts in a specific numbered position. e.g., A may fence the first and third bouts in the number 2 position while B fences the second bout in that number 2 position. This means that a fencer who has been replaced may return to the line-up, but *only* in the numbered position he originally occupied.

f. When a substitute has been entered into the lineup, and his bout has been called, he must be on the strip ready to fence within 1 minute, or the opposing team may claim the bout forfeit. The substitute MAY NOT be replaced in the lineup for that bout by the original fencer, or by a second

substitute, once his bout is called.

g. Only after clear and explicit agreement between opposing coaches or captains for that specific case may a substitute into a lineup replace more than one fencer, and never in more than one weapon. He may not under any conditions meet the same opponent more than once. This means that if the opposing coaches do not agree in this specific case, then Rules 525a through 525f apply.

h. The scorer must accept instructions only from the team's coach or captain when writing a substitution onto the scoresheet.

i. A substitution not in accordance with these Rules can result in that bout being claimed as forfeit by the opposing team. The jury of final appeal is the bout committee for the dual or multiple meet, or, lacking a bout committee, the director of the bout.

526 A BOUT COMMENCED OUT OF ORDER: The director may, with explicit approval of the opposing coaches, deliberately call for a bout to be fenced out of order for the specific purpose of saving time.

a. If a bout which has been called out of order is "effectively commenced." Cf. 231/3/a, the director can declare the bout forfeit to the offended team if BOTH of two conditions are met:

(1) The director can determine beyond his own doubt that one team is clearly at fault for the situation, e.g., the use of a fencer other than the one whose name is on the scoresheet without proper substitution (2) The opposing coach requests that the bout be declared forfeit. The jury of final appeal is the same as ART. 525i.

b. If the director cannot determine beyond his own doubt that the miscall is clearly the fault of one team, then the bout must be completed, its score entered in its PROPER place on the scoresheet, and then skipped as it comes up in the sequence. Bouts called out of order are usually the result of confusion on the part of inexperienced scorers. It is the directors' responsibility to be aware of such conditions, and to guide the scorers and timers in keeping things orderly on his strip.

527 The use of a fencer who is not eligible to compete under the applicable rules of his college, university or school must result in the forfeiture of the entire meet to the opposing team by the maximum possible score.

528 If a fencer fails to appear on the strip ready to fence within 1 minute of the time his bout is called, without having first secured the specific permission of the director, then the opposing team may claim that bout as forfeit.

529 INDIVIDUAL COMPETITIONS may be organized: a. By pools; b. By double elimination; c. By a combination of these two.

530 The NCAA CHAMPIONSHIPS are organized by pools in each of 3 weapons.

a. Four preliminary pools of up to 12 fencers each, qualifying the top 4 fencers directly to the final round; and the next 4 fencers to:

b. Two repechage pools of 8 fencers each containing contestants ranked 5, 6, 7, 8, from each of the four preliminary pools. The first 4 from each repechage pool qualify for:

c. A final round robin pool of 24 fencers in each weapon.

531 The NCAA CHAMPIONSHIPS:

a. May be entered by fencers from any member institution, but the entry must be submitted by the institution, not the individual.

b. No member institution may enter more than one fencer in each weapon, but the institution is not required to enter a fencer in each weapon.

c. The results of the Tournament determine the individual National Collegiate Champion in each weapon, and the NCAA ranking of individual entries.

d. National Collegiate Team Championship and NCAA national team rankings are also determined here. Points toward the Team Championship are earned as follows:

- (1) Participation in the preliminary round by a fencer earns 1 point plus the actual number of bouts won in the preliminary round for his team;
- (2) Fencers who advance to the final round begin the round with 10 points;
- (3) Each victory in the Final Round of 24 earns 1 additional point for the fencer's team. In the determination of team ranking, TIES ARE NOT BROKEN, except for 1st, 2nd or 3rd places. When Teams a.b.c. are tied for 4th place, all three are 4th, and the team with the next highest point total is ranked 7th because 5th and 6th places have been occupied by the 4th place tie.
- (4) When 2 teams tie for 1st, 2nd or 3rd place, they must fence off in a 3 bout match, 1 bout sabre, 1 bout foil, 1 bout epee.
- (5) When 3 teams fence off a tie for 1st, 2nd or 3rd, they must draw lots for the order of matches to be fenced off. The team losing the first match will then fence the third team.

532

a. THE SEEDING COMMITTEE will, by evaluating the best and most current information available to it, rank the individual entries from top to bottom and distribute them among the 4 preliminary pools. The first concern of the committee must be EQUITY in distribution of contestants. Intercollegiate dual meet, regional or conference tournament, and AFLA tournament records for the current season should be given priority over previous season records in order to be as objective and up to date as possible in establishing ranking. (1) Pattern of Assignment of Ranked Fencers to pools:

| POOLS | I | II | III | IV |
|-------|----|----|-----|----|
| | 1 | 2 | 3 | 4 |
| | 8 | 7 | 6 | 5 |
| | 9 | 10 | 11 | 12 |
| | 16 | 15 | 14 | 13 |
| | 17 | 18 | 19 | 20 |
| | 24 | 23 | 22 | 21 |
| | 25 | 26 | 27 | 28 |
| | 32 | 31 | 30 | 29 |
| | 33 | 34 | 35 | 36 |
| | 40 | 39 | 38 | 37 |
| | 41 | 42 | 43 | 44 |
| | 48 | 47 | 46 | 45 |

b. Qualification for the Final Round of 24:

- (1) The fencers who place in top 4 of each preliminary pool are promoted to the Final Round of 24. If there is a tie for 4th place in bouts won and lost, then indicators will be used to break the tie. The "indicator" is the number of touches scored divided by the number of touches received (TS/TR). An indicator tie necessitates a fence-off bout.
- (2) The 5th, 6th, 7th, and 8th place fencers in each of the 4 preliminary

pools qualify for 2 REPECHAGE Pools of 8. Ties for 8th place in the preliminary pools will be broken by use of the indicator. An Indicator tie necessitates a fence-off.

(3) The top 4 in each of the Repechage Pools are promoted to the Final Round of 24. In the Repechage Pools, ties for 4th place must be FENCED-OFF. The indicator is not used in this case.

533 a. The FINAL ROUND of 24 is a complete Round-Robin competition. Ties for 1st place only are fenced off. Ties for all other places are broken by use of the indicator. Indicator ties WILL NOT be fenced off in this case. The tied fencers will be awarded the higher rank.

534 Conference and regional tournaments for individuals, which are also conducted for team honors, are customarily operated along lines similar to those of the NCAA Championships, but with specific variations according to the needs and customs of the regions or conferences.

535 Invitational tournaments for collegiate fencers, but not for team honors, may be, but are not required to be, operated along lines similar to those of the NCAA Championships.

536 ORDER OF BOUTS:

a. For pools of competitors from 4 to 10 in number, bout orders may be found in Art. 526 of the AFLA Rules Book.

b. To develop bout orders for round robin pools of more than 10 contestants, the total entry can be broken into groups or "sets" of 3 or 4 fencers each, and the "sets" fenced against each other, MAKING SURE that each set fences against itself, and that each set meets EVERY other set. (In past years, the NCAA Championships have been operated in complete round robin systems of as many as 39 contestants.)

537 WITHDRAWAL FROM COMPETITION: NCAA Championships: If a fencer withdraws from the competition with fewer than half the total number of bouts scheduled for him in that pool fenced, the results of those bouts are voided, and the remainder of the bouts scheduled for him are stricken from the records of the pool. If withdrawal occurs with half, or more than half, of the bouts scheduled for the withdrawing fencer completed, then the bouts completed become part of the record for the pool, and the remaining bouts scheduled for him are scored as 5-0 losses. In competitions other than the NCAA Championships, special rules for withdrawal usually apply.

538 SCORING PROCEDURES:

a. In the NCAA Championships, the bout is scored on a small two-part card, which is given to the scorer as part of a pack arranged in the proper bout order. At the conclusion of the bout, the director MUST certify the score by initialing the card, and the WINNER must then take that card to the master scoring table. There the card is split, and the "V" part is stuck to the master scoreboard in its proper place for the winner, and the "D" part of the card is stuck to the master scoreboard in its proper place for the loser. The card then serves both as part of the scoreboard, and part of the permanent record. At the scoring table for the strip, a printed bout schedule is used to double check the order of cards in the pack.

b. Conference and regional tournaments use scoring systems which best meet their needs.

c. In dual meets between teams, various types of score sheets are used. The simplest type, which facilitates operation by inexperienced scorekeepers, is similar to what follows:

| A. B. College | | SABRE | S. T. University | |
|------------------|-------|-------|--------------------|--------|
| Name | Score | | Name | Score |
| 1. Joe Josephs | /// | V | 1. Al Alberts | +++ D |
| 2. Mike Michaels | +++ | D | 2. Fred Fredericks | // V |
| 3. Jack Johns | //// | V | 3. Tom Thomas | +++ D |
| 1. Josephs | +++ | D | 2. Fredericks | 0 V |
| 2. Michaels | / | V | 3. Thomas | +++ D |
| 3. Johns | +++ | D | 1. Alberts | // V |
| 1. Josephs | 0 | V | 3. Thomas | +++ D |
| 2. Michaels | +++ | D | 1. Alberts | //// V |
| 3. Johns | // | V | 2. Fredericks | +++ D |

Total Victories 5Total Victories 4

Similar score sheets are used for each weapon, and the three sheets give a record of the meet, which is given to EACH team. The process is repeated as many times as necessary in multiple meets.

PART SIX—DISCIPLINARY RULES

The articles in this section are the same as those in the equivalent section of the AFLA Rules Book, with the following variations and clarifications:

603 By the fact of their involvement in a fencing competition, all persons pledge their honor, AND THE HONOR OF THE INSTITUTIONS THEY REPRESENT, to observe the regulations, and the decisions of directors and judges, to be respectful toward members of the Jury, and to obey the orders and instructions of the director.

609 a. In all completions, if more than one contestant represents the same institution, then they MUST be under the direction of a coach, or a team captain. This individual is directly responsible to the Bout Committee for the good behavior, conduct and sportsmanship of all of the members of his team.

b. The coach, or the captain, has the right to deal with the director, or with the Bout Committee regarding technical matters, to register protests, or to make observations, Cf. 659.

610 The Director, Side Judges and Ground Judges must perform their functions with COMPLETE IMPARTIALITY and with continuous and conscientious attention to the action on the strip; Cf. 652.

611 Coaches, trainers, technicians and team-mates are allowed to remain near the strips on which their contestants are fencing. However, they are forbidden to intervene in any way with the progress of the bout.

a. They may not go on the strip to give medical or technical help to a contestant without the expressed or clearly implied permission of the director.

b. In Championships and Tournaments, no visual or audible instructional communication between a contestant and any person other than the director is permitted.

c. No person may communicate instructions to a contestant by either vis-

ual or audible means, even when the bout is stopped. As an exception, in dual or multiple meets only, the director may grant permission to take one minute time out for that purpose. Such permission may be granted only once for each contestant during a bout; Cf 656.

612 Spectators may not interfere in any way with the good order of a competition.

a. They may do nothing which may tend to influence or intimidate the fencers or the jury. They must respect decisions, whether or not they approve of them.

b. They must obey any instructions a director may deem it necessary to give them.

c. They may not communicate instructions to a contestant by either audible or visible means.

636 WARNINGS AND PENALTIES:

a. When the infliction of a penalty requires prior warning, this warning must be given distinctly, in such manner as to be clearly understood by the fencer warned. It must clearly state the duration of the warning (for the bout, pool, meet, or tournament). Repetition of the offense for which the warning was given, during the period under warning, results in the penalty laid down in the rules for the specific infraction. After the warning period has expired, a new warning, not the penalty, must be given for repetition of the infraction.

b. IN THE NCAA CHAMPIONSHIPS: Any warning which carries for more than the length of one bout shall have a maximum duration of five (5) bouts, if the infraction occurs during the Final Round of 24. If an offense is committed in the Preliminary or Repechage round, and the standard warning is for the duration of the pool, then the warning should be issued for the duration of the round.

646 For indisposition, including cramp: a rest period of up to 10 minutes (one only) and a warning for the dual meet or pool; on repetition of the indisposition within the warning period, the director must require the withdrawal of the contestant from the dual meet or tournament. The bout from which the fencer is withdrawn is scored as a loss against the fencer. In a dual meet, the fencer may be replaced in the lineup for any subsequent bouts scheduled for his numbered position. In a tournament he may not be replaced; Cf. 51.

647 If a fencer in a dual meet is injured to an extent that it is deemed unwise for him to continue fencing, he may be replaced in the lineup for that bout, and the bout begun over again, with the score of the bout in which the accident occurred being completely voided. The opposing team may also replace its fencer in the lineup for that bout under the substitution rules; Cf. 565. The dual meet may then continue under the rules of organization.

649 If an institution enters an individual contestant who does not meet its own standards of eligibility in a NCAA Championship, or NCAA sanctioned competition, then the entire entry of that institution is disqualified from that competition.

PART SEVEN—EQUIPMENT FOR THE AUTOMATIC REGISTRATION OF TOUCHES

Articles 701-733 are the same as the same numbered articles of the AFLA Rules Book.

SUDRE FENCING EQUIPMENT COMPANY

5 WESTWOOD KNOLL

ITHACA, N.Y. 14850

*Only if nothing but the best
is good enough for you.*

**INTERNATIONAL FENCING
CAMP, INC.**

RAOUL SUDRE, *Director*

- Intensive Training Summer Camps
 - Coach's Clinics
 - Regional One to Three Days Clinics
-

THE AMERICAN FENCING ACADEMY

A TWO YEAR POST GRADUATE COURSE
TOWARDS THE MASTER'S DEGREE.

For information write to:

RAOUL SUDRE
5 Westwood Knoll
Ithaca, N.Y. 14850